



Dual Output Step-Up Converter for White LED Backlighting and OLED Display Power Supply

DESCRIPTION

The EUP2520 is a dual step-up DC/DC converter, uses a single inductor and a schottky diode to provide two outputs. One is designed to drive up to 5 white LEDs with a constant current and the other is to power an organic LED display with a constant voltage. Each output is enabled by individual logic inputs.

A single external resistor is used to set the maximum LED current. The LED current can be adjusted by applying a PWM signal to the EN pin. For higher efficiency the EUP2520 operates with pulse frequency modulation (PFM) control scheme when the sub-display is enabled. When Main display is enabled, the device is operating in PWM mode. Overvoltage protection circuitry and a 1MHz switching frequency allow for the use of small, low cost external components.

Additional features include a low-side NFET switch that can turn off the LED string with no DC current path to ground. The EUP2520 is available in a small 12-pin thermally-enhanced TDFN package.

FEATURES

- 2.7V to 5.5V Input Voltage Range
- Up to 5 LEDs at 20mA and 4 LEDs at 30mA for Main-display Backlighting
- Up to 20V @ 50mA for OLED Sub-display
- Output True shutdown
- 80% Efficiency
- 0.7A DMOS Switch
- 1MHz Switching Frequency
- 23V Over Voltage Protection
- Cycle-By-Cycle Current Limit
- PWM Dimming Control
- 3mm × 3mm TDFN-12 Package
- RoHS Compliant and 100% Lead (Pb)-Free

APPLICATIONS

- Clam-shell Cellular Phones with OLED/LCD Displays

Typical Application Circuit

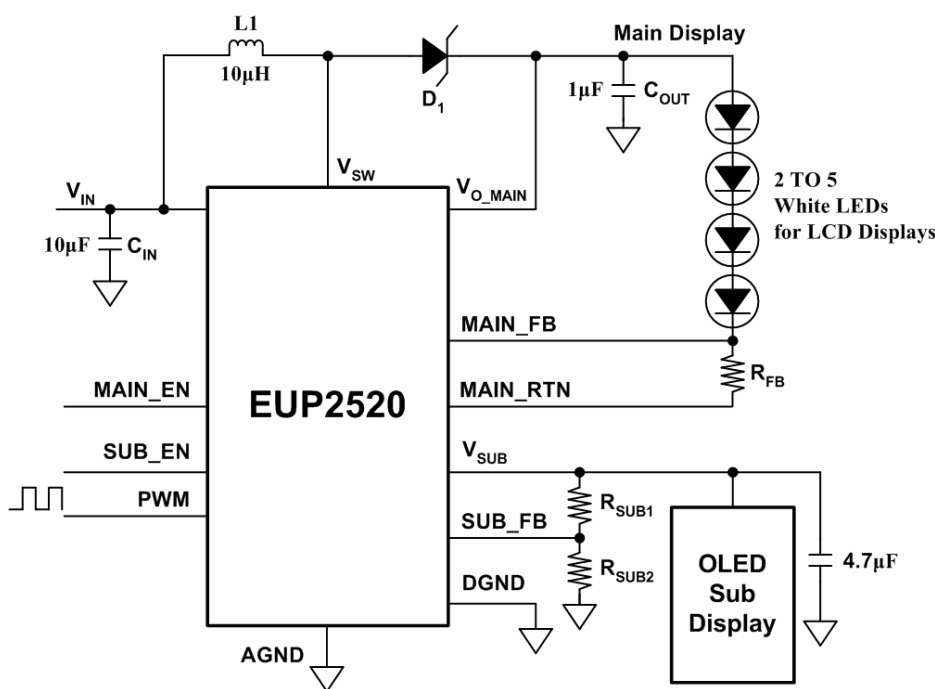

Figure 1.

Pin Configurations

Package Type	Pin Configurations
TDFN-12	<p>(TOP VIEW)</p> <p>The diagram shows a top view of a rectangular package with 12 pins. The pins are numbered 1 through 12. Pin 1 is labeled V_{SW}, pin 2 is V_{IN}, pin 3 is AGND, pin 4 is MAIN_EN, pin 5 is SUB_EN, pin 6 is PWM, pin 7 is SUB_FB, pin 8 is V_{SUB}, pin 9 is V_{O_MAIN}, pin 10 is MAIN_FB, pin 11 is MAIN_RTN, and pin 12 is DGND. A dashed line indicates the package boundary.</p>

Pin Description

PIN	Pin	DESCRIPTION
V _{SW}	1	Switching Voltage
V _{IN}	2	Input Voltage
AGND	3	Analog Ground
MAIN_EN	4	Main Enable
SUB_EN	5	Sub Display Enable
PWM	6	PWM Dimming for Main Display, When PWM=HIGH, White LEDs operating at maximum current
SUB_FB	7	Sub Display Feedback
V _{SUB}	8	Sub Display Power Supply Voltage
V _{O_MAIN}	9	Main Output Voltage
MAIN_FB	10	Main Display Feedback
MAIN_RTN	11	Main Display Return Voltage
DGND	12	Digital Ground

Ordering Information

Order Number	Package Type	Marking	Operating Temperature range
EUP2520JIR1	TDFN-12	XXXXX 2520A	-40 °C to 125°C

EUP2520

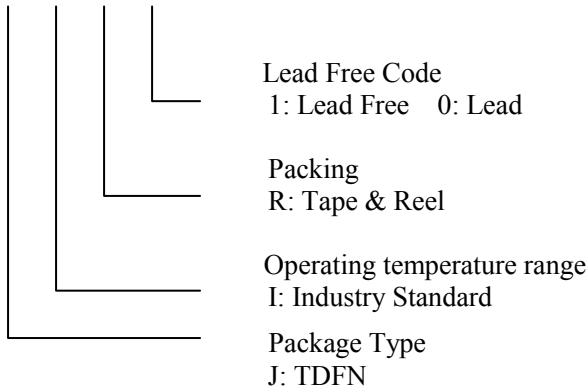

Block Diagram

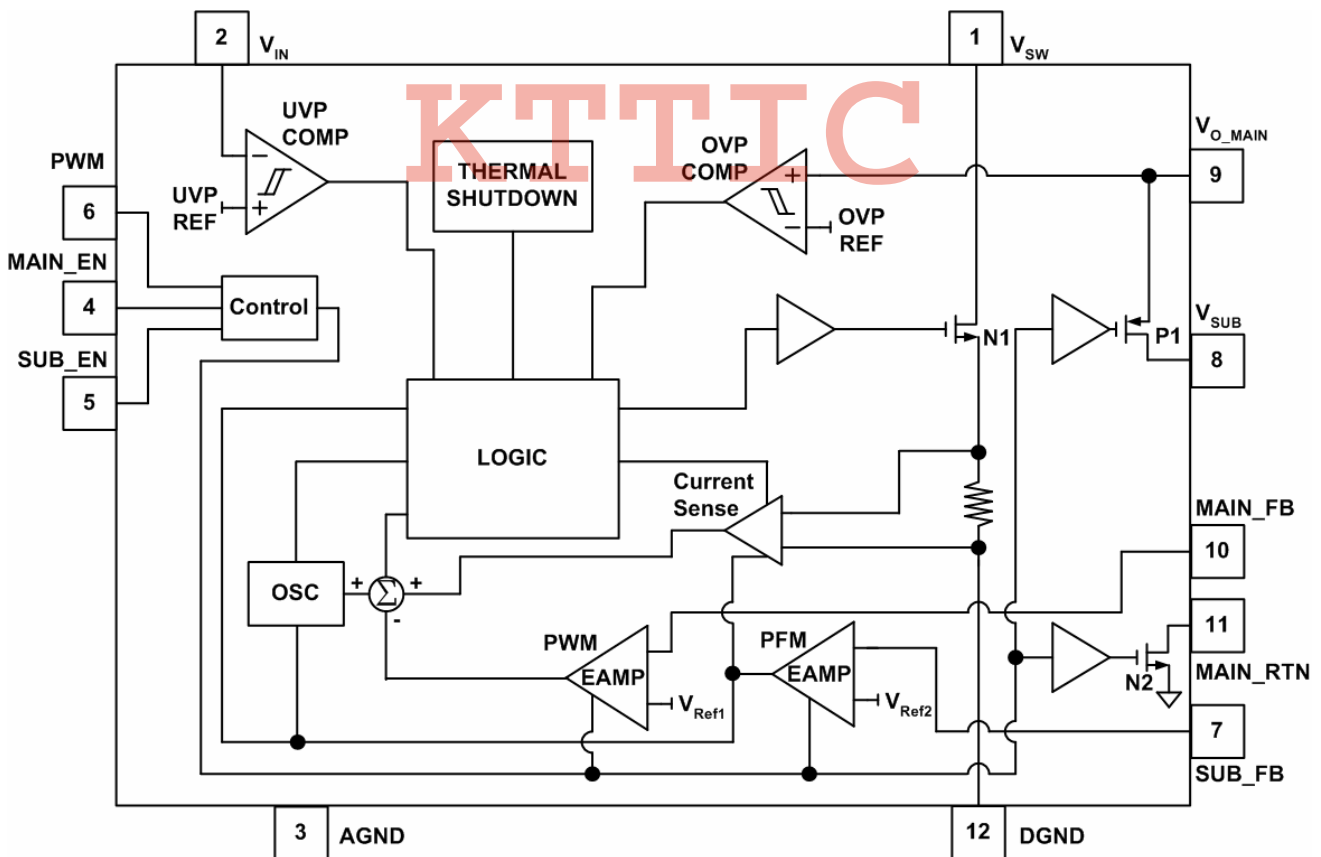

Figure 2.

Absolute Maximum Ratings

- V_{IN} ----- -0.3V to 6V
- V_{O_MAIN} ----- -0.3V to 25V
- V_{SW} ----- -0.3V to $V_{OUT}+0.3V$
- Main_FB, Main_RTN, MAIN_EN, PWM & SUB_EN ----- -0.3V to 6V
- Thermal Resistance
TDFN-12 (J_A)----- 55°C /W
- Maximum Junction Temperature (T_{J-MAX})----- 150°C
- Junction Temperature Rang (T_J)----- -40°C to 125°C
- Storage Temperature Range ----- -65°C to 150°C
- Lead Temperature (Soldering, 10sec.) ----- 265°C

Recommended Operating Conditions

- Supply Voltage, V_{IN} ----- 2.7V to 5.5V
- Operating Temperature Rang (T_A)----- -40°C to 85°C

Electrical Characteristics

$V_{IN}=3.6V$, $L=10\mu H$, $C_{IN}=10\mu F$, $C_{OUT}=1\mu F$, $C_{SUB}=4.7\mu F$, $R_{SUB1}=100K\Omega$, $R_{SUB2}=6.6K\Omega$, $T_A=-40$ to 85 ,
Unless otherwise noted. Typical Values are at $T_A=25$.

Symbol	Parameter	Conditions	EUP2520			Unit
			Min	Typ	Max.	
Enable Threshold	Low				0.3	V
	high		0.95			
I_{EN}	Enable Pin Current	MAIN_EN=3.6V		3	5	μA
		SUB_EN=3.6V		3	5	
		PWM=3.6V		3	5	
I_Q	Quiescent Current , Device Not Switching (PWM mode)	MAIN_FB>0.5V		0.5	0.8	mA
	Quiescent Current , Device Not Switching (PFM mode)	SUB_FB>1V		0.25	0.45	
	Quiescent Current , Device Not Switching	MAIN_EN=0V or SUB_EN=0V (open loop)		1.75	4.5	
	Power Off Current (Shutdown)	MAIN_EN=0V SUB_EN=0V PWM=0V		1	2	μA
V_{FB}	Feedback Voltage (MAIN_FB)	$V_{IN}=3.6V$	0.455	0.5	0.545	V
	Feedback Voltage (SUB_FB)	$V_{IN}=3.6V$	1.18	1.23	1.28	
I_B	FB Pin Leakage Current	MAIN_FB=0.5V		10		nA
	FB Pin Bias Current	SUB_FB=0V		50		
$I_{Current\ Limit}$	Switch Current Limit	$V_{MAIN_FB}=0V, V_{IN}=3.6V$	0.5	0.7	0.9	A
$R_{DS(ON)}$	Main_Switch $R_{DS(ON)}$, N1	$I_{SW}=300mA$		0.5		
	PMOS Switch $R_{DS(ON)}$, P1	$I_{PMOS}=20mA$		3		
	Main_RTN $R_{DS(ON)}$, N2	$I_{Main_RTN}=30mA$		3		

Electrical Characteristics

$V_{IN}=3.6V$, $L=10\mu H$, $C_{IN}=10\mu F$, $C_{OUT}=1\mu F$, $C_{SUB}=4.7\mu F$, $R_{SUB1}=100K\Omega$, $R_{SUB2}=6.6K\Omega$, $T_A=-40$ to 85 ,
 Unless otherwise noted. Typical Values are at $T_A=25$.

Symbol	Parameter	Conditions	EUP2520			Unit
			Min	Typ	Max.	
$I_{main_RTN_leakage}$	Main_RTN Leakage Current	$V_{Main_RTN}=0.5V$, $V_{IN}=3.6V$			0.2	μA
D_{Limit}	Duty Cycle Limit at PWM & PFM	$V_{FB}=0V$, $V_{IN}=3.6V$		92		%
F_{SW}	Switching Frequency	$V_{IN}=3.6V$	0.8	1.1	1.4	MHz
I_{Leak}	Switching Leakage Current	$V_{SW}=24V$		0.01	0.5	μA
OVP	Threshold	Rising	22.2	23.2	24.2	V
		Falling	21.5	22.5	23.5	
UVP	Threshold	Rising	2.35	2.45	2.58	V
		Falling	2.3	2.4	2.53	
$I_{Vout_main_leak}$	V_{OUT} Leakage Current	$V_{OUT}=V_{IN}$, $MAIN_EN=SUB_EN=0V$		0.1		nA
$I_{Vout_main_bias}$	V_{OUT} Bias Current at No Load	$V_{OUT}=20V$, $SUB_EN=0$		40	60	μA

KTTIC

Typical Operating Characteristics

Switching Quiescent Current vs. Vin
(Disconnected LEDs from VO HAIN & Rsub1 from Vsub)

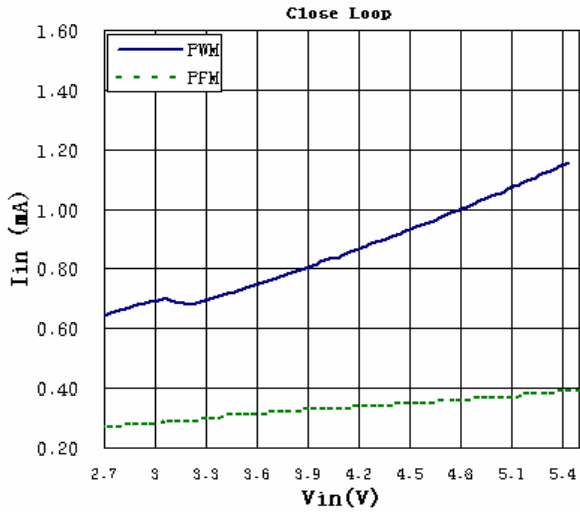

Switching Quiescent Current vs Vin
(Disconnected LEDs from VO HAIN & Rsub1 from Vsub)

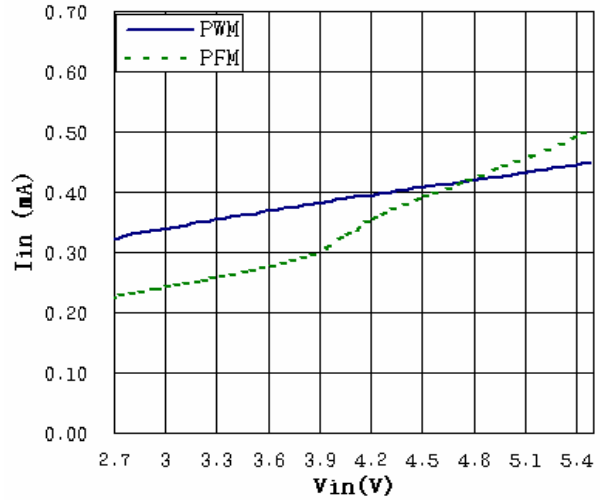

Duty Cycle vs. Load Current
(PWM at PFM_EN) Vin=3.6V

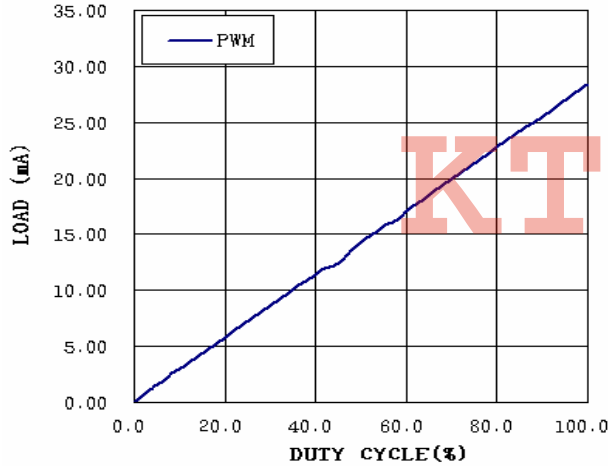

Vsub(18V) vs. Load

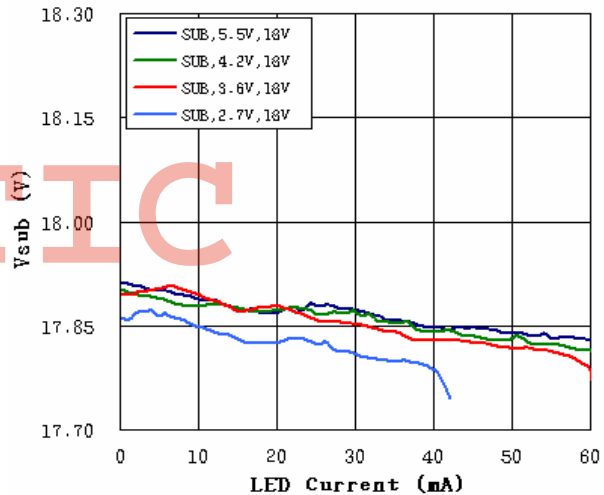

Vsub(15V) vs. Load

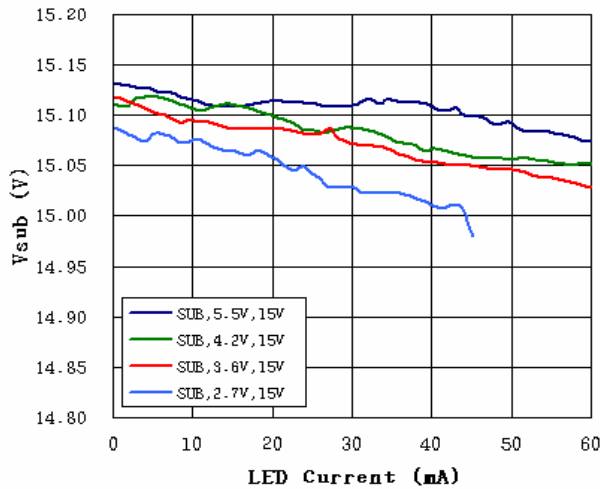

Feedback Voltage vs. Vin (4LED)

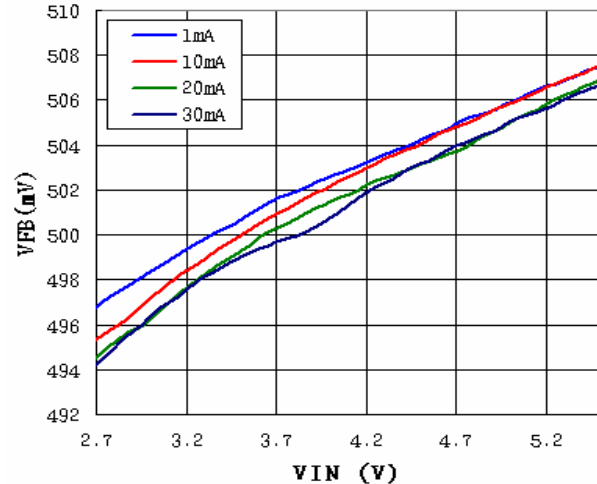

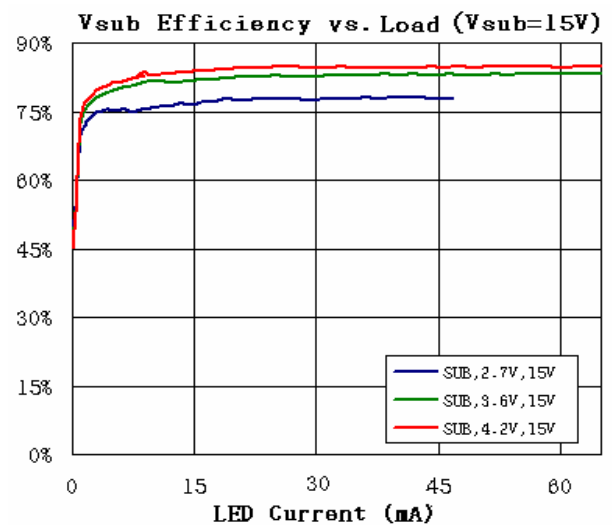
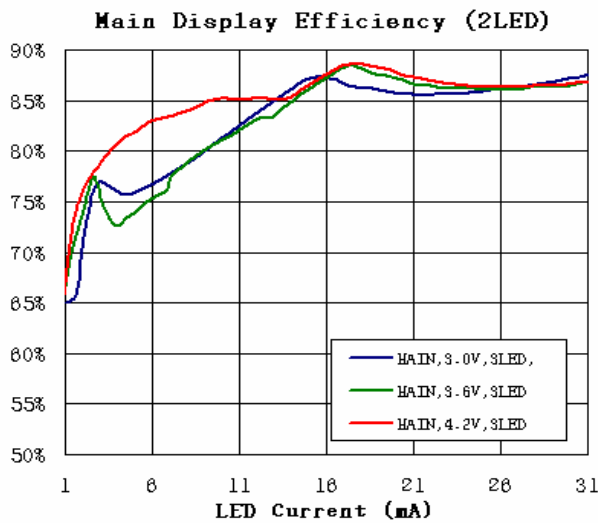
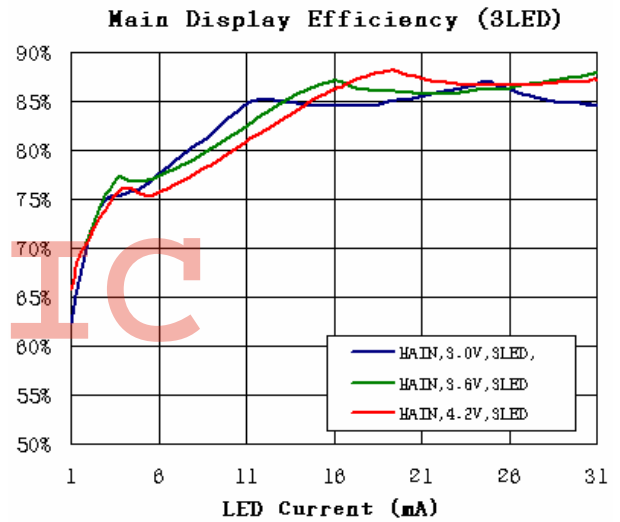
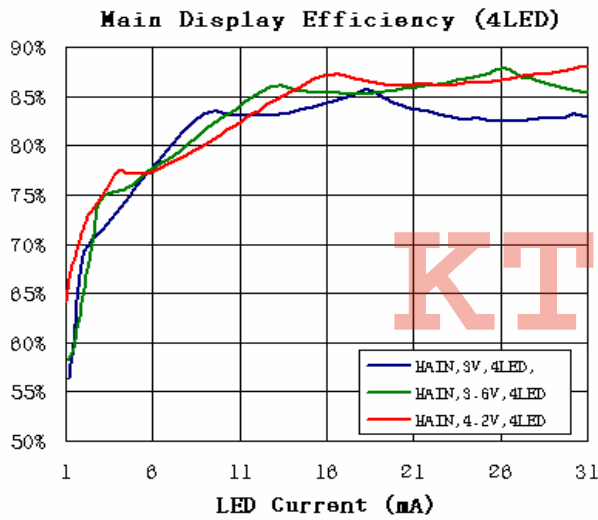
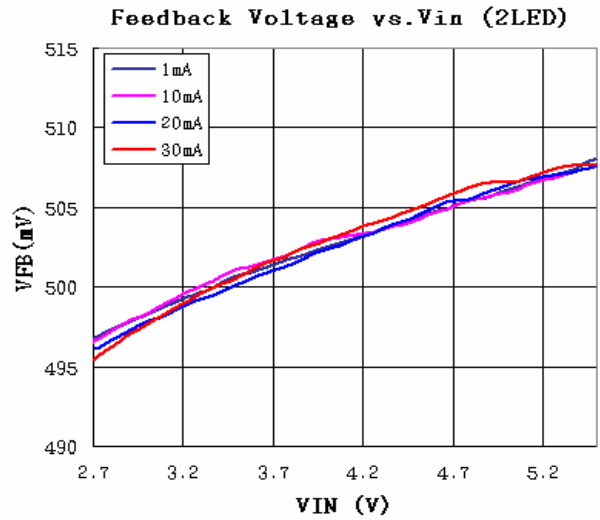
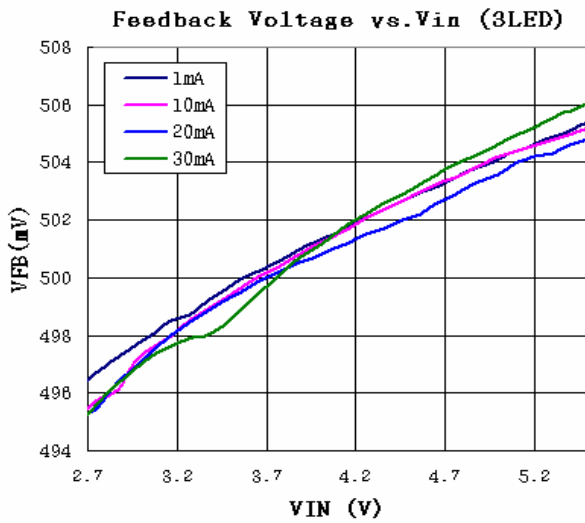

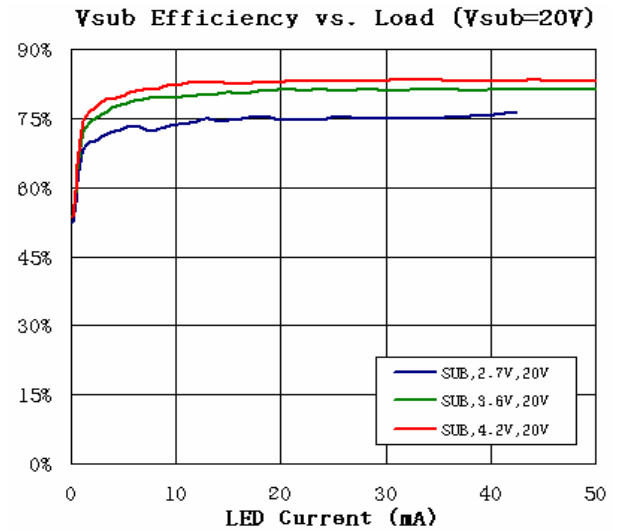
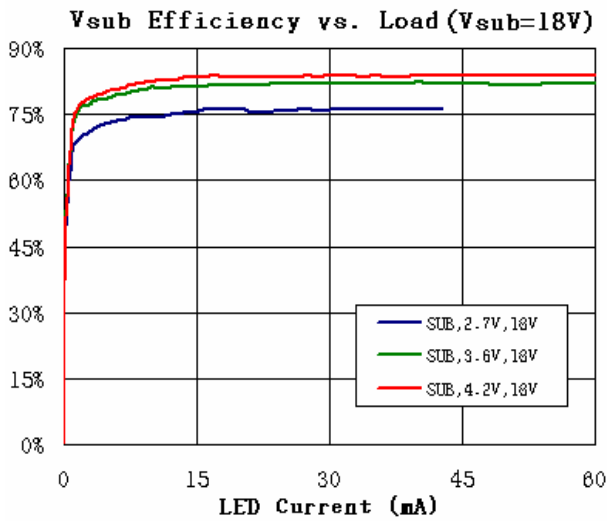

Typical PWM Switching Waveform
(Vin = 3.6V at 30mA LED Current)

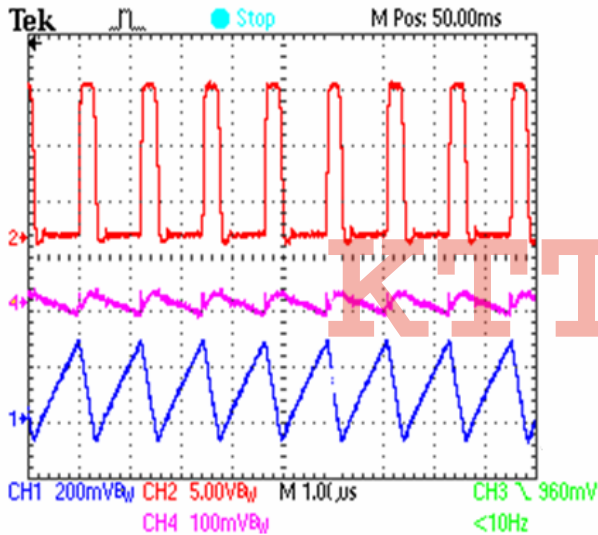

Typical PWM Switching Waveform
(Vin = 3.6V at 4mA LED Current)

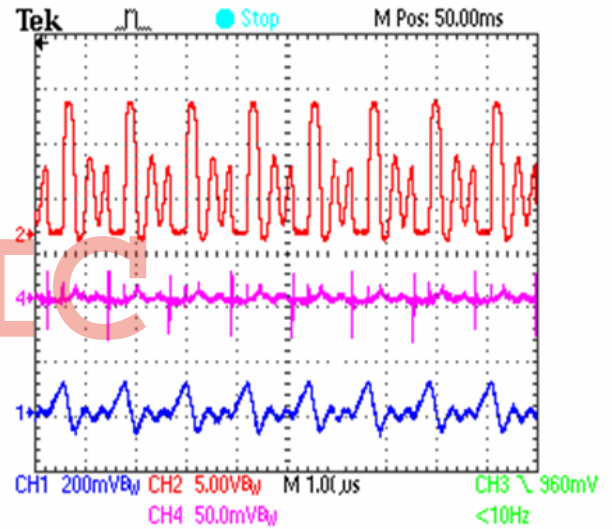

Typical PFM Switching Waveform
(Vin = 3.6V, at 30mA Load Current)

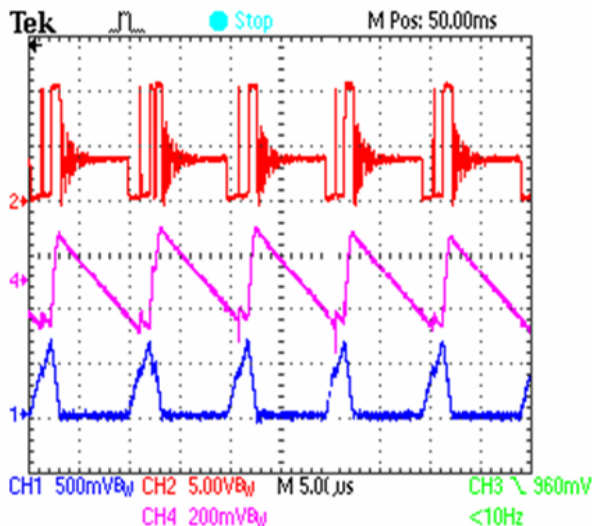

Typical PFM Switching Waveform
(Vin = 3.6V at 4mA Load Current)

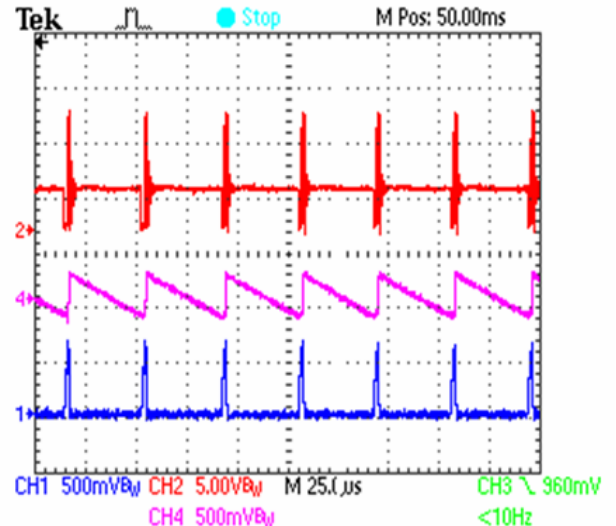

Operation Modes

The EUP2520 has two operating modes; Figure 3 shows main display in PWM current mode operation, the appropriate selection of R_{FB} resistor in series with four white LEDs set the output current driving the main display. Figure 4 shows Sub display in PFM mode, the appropriate selection of R_{SUB1} and R_{SUB2} resistors set the output voltage driving the OLED subdisplay.

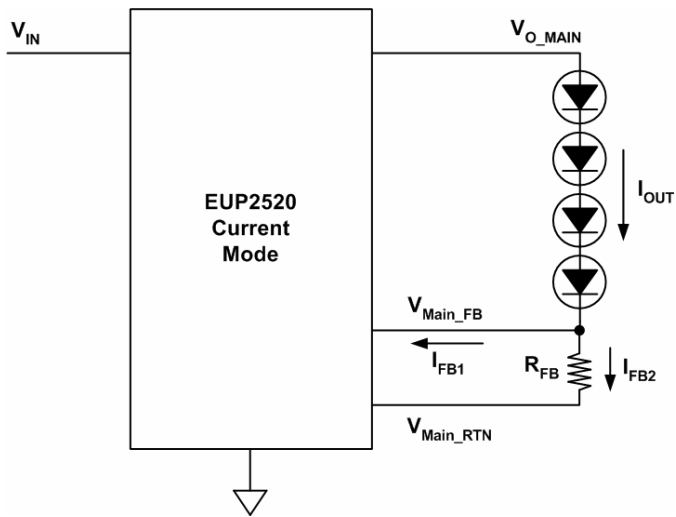

Figure 3. Main Display

$$I_{LED} = \frac{(V_{MAIN_FB} - V_{MAIN_RTN})}{R_{FB}}$$

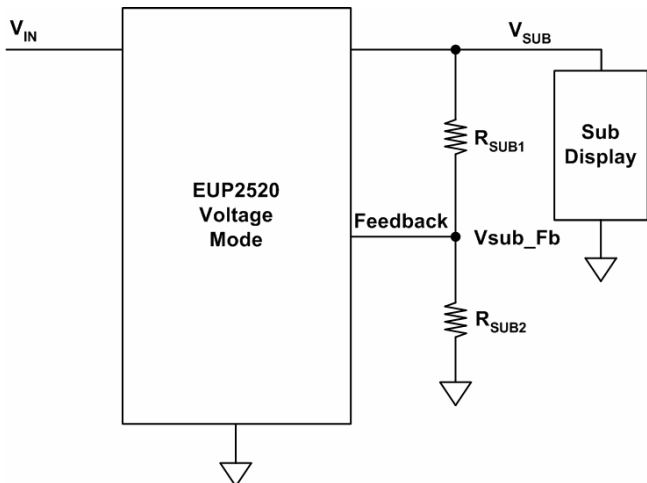

Figure 4. Sub Display

$$V_{SUB} = \frac{(R_{SUB1} + R_{SUB2})}{R_{SUB2}} * V_{SUB_FB}$$

Circuit Description

The EUP2520 is designed for White LED & OLED backlighting in mobile phone applications. It has a main display loop which can drive up to 5 white LEDs in series and a sub display loop which is designed to drive OLED up to 20V/50 mA. The main display loop employs a fixed frequency current mode scheme to regulate the LED current. The sub display loop employs a fixed frequency gated oscillator scheme to regulate the output voltage. The device has two independent control pins to enable the Main or Sub displays. Note that both displays can not be ON at the same time

PWM Operation

The EUP2520 utilizes a synchronous Current Mode PWM control scheme to regulate the feedback voltage over all load and line conditions for the main display. The EUP2520 is internally compensated preventing the need for external compensation components yielding a compact solution. The operation can best be understood referring to the functional block diagram. The EUP2520 operates as follows: During the first cycle, the oscillator sets the driver logic and turns on the NMOS power device conducting current through the inductor and reverse biases the external diode isolating the output from the V_{SW} node.

The LED current is supplied by the output capacitor when the NMOS power device is active. During this cycle, the output voltage of the EAMP controls the current through the inductor. This voltage will increase for larger loads and decrease for smaller loads limiting the peak current in the inductor. The sum of the EAMP voltage and voltage ramp is compared with the sensed switch voltage. Once these voltages are equal, the PWM COMP will then reset the logic turning off the NMOS power device and forward biasing the external diode to the white LED load and flows through the diode to the white LED load and output capacitor. The inductor current recharges the output capacitor and supplies the current for the white LED branches. The oscillator then sets the driver logic again repeating the process.

PFM Operation

The EUP2520 utilizes a gated oscillator control scheme for the sub-display. There is a hysteresis window to regulate the output voltage. The oscillator frequency is the same as the frequency in PWM control. The Duty cycle of the oscillator signal is always set to maximum. During the first part of each switching cycle, the internal NMOS switch is turned on until the PFM current limit is reached. When the NMOS is off, the voltage of the inductor reverses and forces current through the diode to the output capacitor. This process continues until the upper comparator hysteresis is reached at which point the NMOS is disabled until the lower comparator threshold is reached and the process repeats again.

Current Limit Protection

The EUP2520 has current limiting protection to prevent excessive stress on itself and external components during overload conditions. The internal current limit comparator will disable the NMOS power device at a typical switch peak current limit of 700 mA.

Output Over-Voltage Protection

The EUP2520 contains dedicated circuitry for monitoring the output voltage. In the event that the primary LED network is disconnected the output will increase and be limited to 23.2V(typ.). There is a ~1V hysteresis associated with this circuitry, which will turn the NMOS off when the output voltage is at 24.2V(max.) until the output voltage reach 22.5V(typ.) or lower. The 23.5V limit allows the use of 25V 1 μF ceramic output capacitors creating an overall small solution for white LED applications.

Under Voltage Protection

The EUP2520 has an UVP comparator to turn the NMOS power device off in case the input voltage or battery voltage is too low preventing an on state of the power device conducting large amounts of current.

Reliability and Thermal Shutdown

The EUP2520 has an internal thermal shutdown function to protect the die from excessive temperatures. The thermal shutdown trip point is typically 160°C, Normal operation resumes when the temperature drops below 140°C.

Startup

The EUP2520 does not include a power on reset circuit and relies on external signal to monitor enable signal. In the event of under voltage condition, the device enable pin must be brought low until the input voltage is above the minimum guarantee voltage (2.7V).

Application Information

Setting LED Current

The White LED current is set using the following equation: For main display:

$$I_{LED} = \frac{(V_{MAIN_FB} - V_{MAIN_RTN})}{R_{FB}} \text{-----(1)}$$

PWM Dimming

The LED current can be controlled using a PWM signal on the enable pin with frequencies in the range of 100 Hz to 1 kHz. While EUP2520 LED current can also be controlled with PWM signal on the PWM pin with frequencies in the range of 20kHz to 33kHz, and LED current is linearly proportional to the duty cycle, the PWM frequency above audible range will minimize audible noise from the inductor and/or output capacitor of the boost converter. The maximum LED current would be achieved with 100% duty cycle on PWM pin.

Setting SUB Voltage

Sub-display voltage is be set by choosing R_{SUB1} and R_{SUB2} as illustrated in Figure 5. If R_{SUB1}>100K, a 0.1uF bypass capacitor should be added to improve performance ,V_{SUB} is calculated as follow:

$$V_{SUB} = \frac{(R_{SUB1} + R_{SUB2})}{R_{SUB2}} * V_{SUB_FB} \text{-----(2)}$$

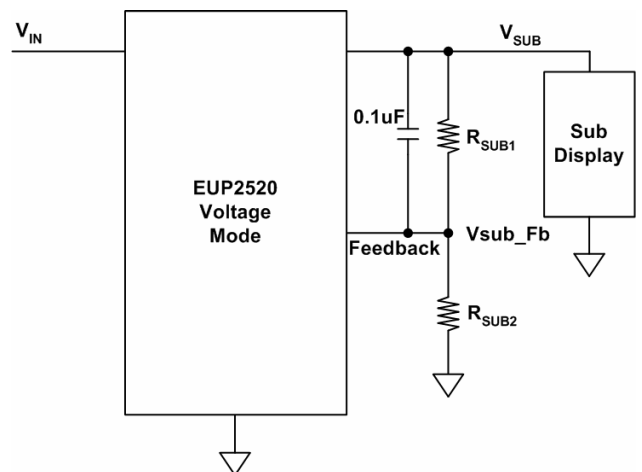

Figure 5.

The above equation to solve for R_{SUB1}.

The EUP2520 is optimized for 20V at 30mA over the input voltage range, for higher output current up to 50mA is achievable with a minimum input of 3.6V. If lower V_{SUB} is desired, the output current capability will be higher.

Using V_{SUB} in Current Mode Configuration

If V_{sub} is used to drive a string of LEDs, instead of using figure 4 configuration (voltage mode). The LEDs can be arranged in current mode configuration to control load current.

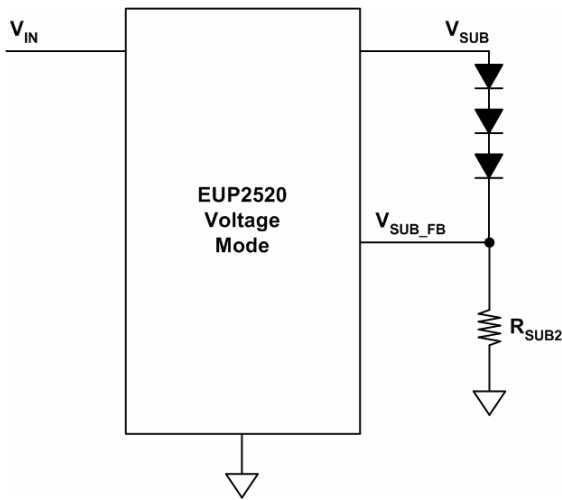

Figure 6.

Main & Sub Enable

The EUP2520 has two independent enable pins to control the main and sub displays. A high on the Main Enable signal will enable the main display. While a high on the Sub Enable pin will enable the sub display. When Main Display enable, PWM pin must be High or PWM Signal. Both Main & Sub enable pins should not be ON at the same time during normal operation. If for any reason, the main and Sub enable are high, the main display will enable by default and the sub display will disable by default. The following truth table summarize the logic state.

Table 1.

MAIN_EN	SUB_EN	PWM	MAIN	SUB
0	0	X	OFF	OFF
1	X	1	ON	OFF
		0	OFF	OFF
		PWM	PWM DIMMING	OFF
0	1	X	OFF	ON

Inductor Selection

The inductor used with EUP2520 must have a saturation current greater than the device switch peak current limit. Choosing inductors with low DCR decreases power losses and increases efficiency. A 10 μH inductor is optimal for the applications. If a smaller inductor is used, the larger the inductor ripple current. Care must be taken to select the inductor such that the peak current rating of the inductor accounts for maximum load current for the operating condition. It is best to select an inductor with a peak current rating of the maximum switch peak current of the device. The following equation is useful for determining the

$$L_{min} = \frac{2 \times I_{OUT_MAX} \times (V_O - V_{IN_MIN} - V_{DIODE})}{I^2_{Peak} \times f_{max}}$$

inductor value for a given application condition. Where I_{OUT_MAX}=maximum output load current, V_{OUT}= output voltage, V_{IN_MIN}= minimum input voltage, V_{DIODE} = diode forward voltage, I_{PEAK}= Peak Current and f_{max} = maximum switch frequency.

Diode Selection

To maintain high efficiency, the average current rating of the schottky diode should be larger than the peak inductor current. Schottky diodes with a low forward drop and fast switching speeds are ideal for increasing efficiency in portable applications. Choose a reverse breakdown of the schottky diode larger than the output voltage. Some recommended diodes are MBR0530T1 from ON semiconductor and CMMSHI-40 from Central Semiconductor.

Capacitor Selection

Choose low ESR capacitors for the output to minimize output voltage ripple. Ceramic capacitors such as X5R and X7R are recommended for use as input and output filters. These capacitors provide an ideal balance between small size, cost, reliability and performance. Do not use Y5V ceramic capacitors as they have poor dielectric performance over temperature and poor voltage characteristic for a given value. For most applications, a 1 μF ceramic output capacitor is sufficient for the main-display. A minimum of 4.7μF output capacitor is recommended for V_{SUB} output. Larger output capacitor can be used to reduce ripple voltage. The EUP2520 has a maximum OVP of 24.2V, a 25V minimum rated capacitor voltage is recommended for the application to ensure proper biasing.

Local bypassing for the input is needed on EUP2520. Multi-layer ceramic capacitors with low ESR are a good choice for this as well. A 10 μF capacitor is sufficient for most applications. Using larger

capacitance decreases input voltage ripple on the input. Extra attention is required if smaller case size capacitor is used in the application. Smaller case size capacitor typically has less capacitance for a given bias voltage as compared to a larger case size capacitor with the same bias voltage. Please contact the capacitor manufacturer for detail information regarding capacitance verses case size.

Layout Consideration

As for any high frequency switcher, it is important to place the external components as close as possible to the IC to maximize device performance. Below are some layout recommendations: 1) Place input filter and output filter capacitors close to the IC to minimize copper trace resistance which will directly effect the overall ripple voltage. 2) Place the feedback network resistors in the Main and Sub display close to the IC. 3) Route noise sensitive trace away from noisy power components. 4) Connect the ground pins and filter capacitors together via a ground plane to prevent switching current circulating through the ground plane. Similarly the ground connection for the feedback network should tie directly to GND plane. If no ground plan is available, the ground connections should tie directly to the device GND pin.

KTTIC

Packaging Information

TDFN-12

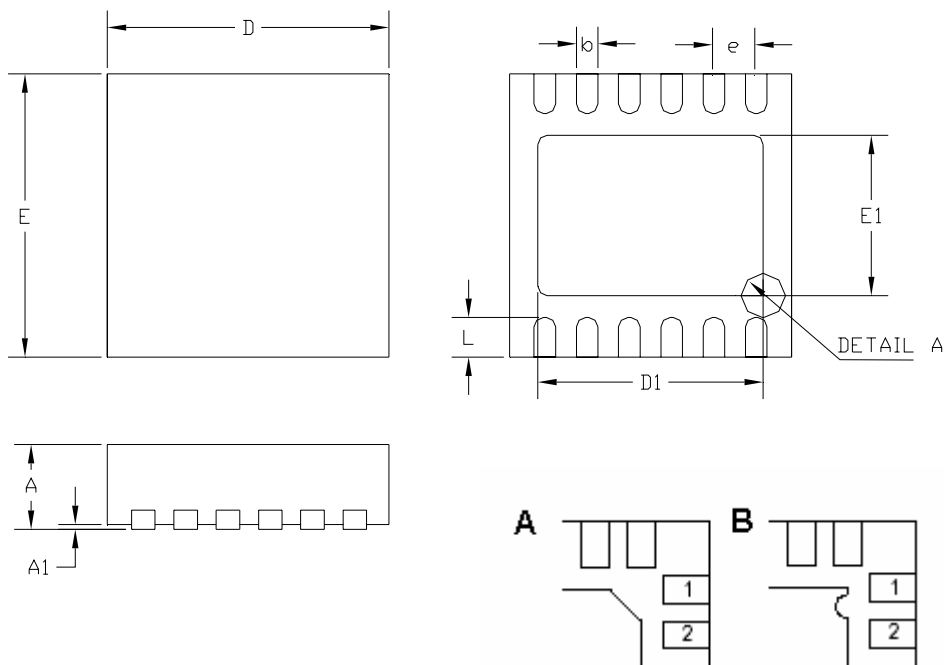

KTTIC **DETAIL A**
Thermal Pad Option

SYMBOLS	MILLIMETERS		INCHES	
	MIN.	MAX.	MIN.	MAX.
A	0.70	0.80	0.028	0.031
A1	0.00	0.05	0.000	0.002
b	0.18	0.30	0.007	0.012
E	2.90	3.10	0.114	0.122
D	2.90	3.10	0.114	0.122
D1	2.40		0.094	
E1	1.70		0.067	
e	0.45		0.018	
L	0.30	0.50	0.012	0.020