



10 White LED Boost Converter In Thin TSOT-23 Package

DESCRIPTION

The EUP2539 is a constant current step-up converter specifically designed to drive white LEDs. The Step-up converter topology allows series connection of the white LEDs, so the LED currents are identical for uniform brightness. The EUP2539 switches at 1MHz, allowing the use of tiny external components. The output capacitor can be as small as 0.22µF, saving space and cost versus alternative solutions. A low 0.3V feedback voltage minimizes power loss in the current setting resistor for better efficiency. The EUP2539 high-voltage output stage is perfect for driving mid-size and large panel displays containing up to ten white LEDs in series. LED dimming can be done by using a DC voltage, a logic signal, or a pulse width modulation(PWM) signal. The enable input pin allows the device to be placed in shutdown mode with “zero” quiescent current.

The EUP2539 is available in low profile TSOT23-5 package.

FEATURES

- 2.6V to 5.5V Input Range
- 38V Output Over Voltage Protection
- Internal Soft-Start
- PWM Dimming Control
- Internal High Power 40V MOSFET Switch
- Fast 1MHz Switching Frequency
- Small, Low-Profile Inductors and Capacitors
- TSOT23-5 Package
- RoHS Compliant and 100% Lead (Pb)-Free

APPLICATIONS

- GPS Navigation Systems
- Portable Media Players
- Handheld Devices, Digital Camera
- Portable Game Machines



Typical Application Circuit

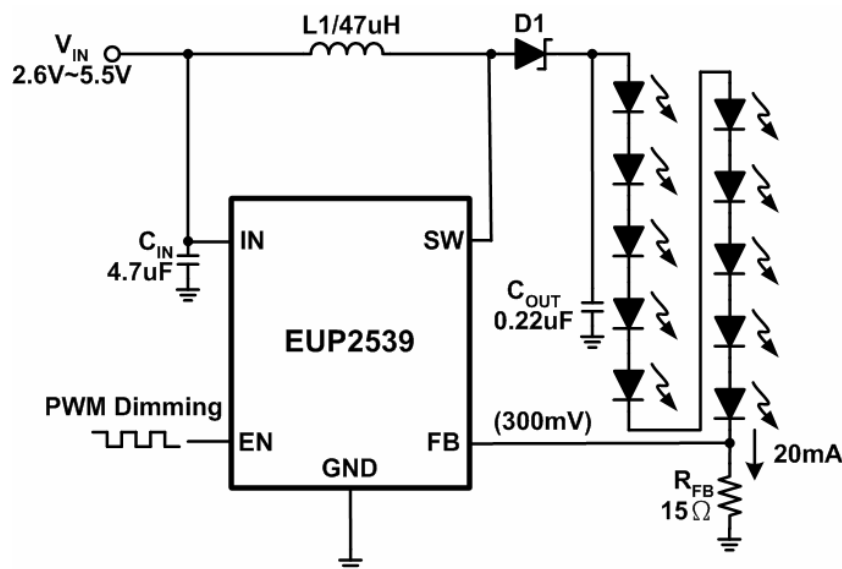

Figure 1. White LED Application

Pin Configurations

Package Type	Pin Configurations
TSOT23-5	

Pin Description

PIN	TSOT23-5	DESCRIPTION
SW	1	Switch Pin. This is the drain of the internal power switch. Connect inductor/diode here. Minimize trace area at this pin to reduce EMI.
GND	2	Common Ground. Connect the pin to the ground plane.
FB	3	Feedback Pin. Reference voltage is 0.3V. Connect cathode of lowest LED and resistor here. Calculate resistor value according to the formula: $R_{FB} = 0.3 / I_{LED}$
EN	4	Chip Enable Pin. Connect it to 1.4V or higher voltage to enable device, 0.3V or less voltage to disable device.
IN	5	Input Supply Voltage

KTTIC

Ordering Information

Order Number	Package Type	Marking	Operating Temperature Range
EUP2539OIR1	TSOT23-5	XXXXX AB00	-40 °C to +85°C

EUP2539

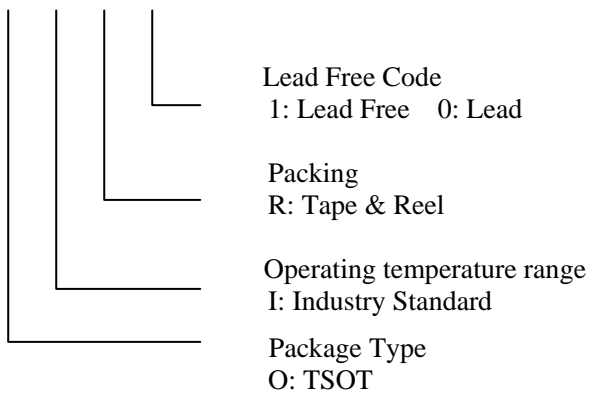

Block Diagram

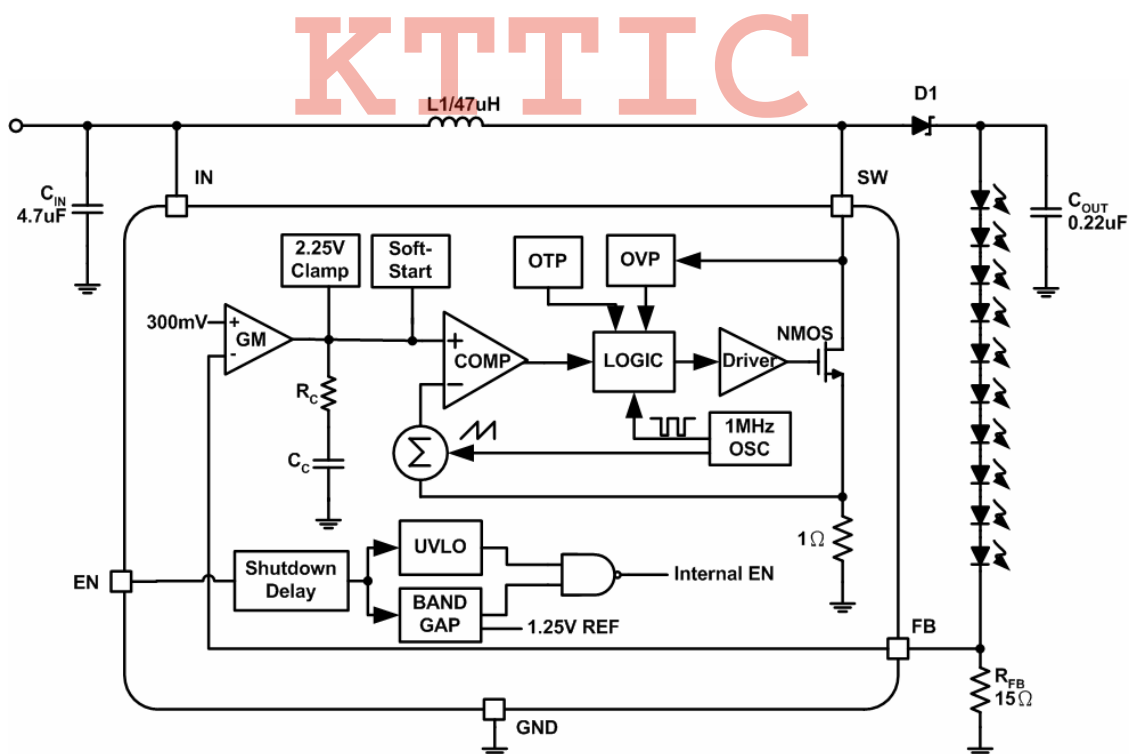

Figure 2.

Absolute Maximum Ratings (1)

- IN, EN, FB to GND ----- -0.3V to 6V
- SW to GND ----- -0.3V to 40V
- Power dissipation, P_D@ T_A=25°C
TSOT23-5 ----- 0.4W
- Package Thermal Resistance
TSOT23-5, J_A ----- 220°C/W
- Maximum Junction Temperature ----- 125°C
- Lead Temperature (Soldering, 10sec.) ----- 260°C
- Storage Temperature Range ----- -65°C to +150°C

Operating Conditions (2)

- Operating Temperature Range ----- -40°C to +85°C
- Supply Voltage , V_{IN}----- 2.6V to 5.5V

Note (1): Stress beyond those listed under “Absolute Maximum Ratings” may damage the device.

Note (2): The device is not guaranteed to function outside the recommended operating conditions.

Electrical Characteristics

(V_{IN} =3.6V, V_{OUT}=34V, C_{OUT}=0.22μF, C_{IN}=4.7μF, L1=47μH, R_{FB}=15Ω, T_A= -40°C to +85°C. Unless otherwise noted. Typical values are at T_A= +25°C)

Symbol	Parameter	Conditions	EUP2539			Unit
			Min	Typ	Max.	
UVLO	Under Voltage Lock Out	Rising	2.2	2.4	2.6	V
	Maximum Output Voltage	No Switching			40	V
I _{CC1}	Supply Current	V _{CC} =5.5V, Continuous Switching		1.7	2.6	mA
I _{CC2}	Quiescent Current	V _{CC} =5.5V, FB=1.3V, No Switching		130	170	μA
I _{CC3}	Shutdown current	V _{CC} =5.5V, V _{EN} <0.4V		0.1	1	μA
Oscillator						
Fosc	Operation Frequency		0.8	1	1.3	MHz
Dmax	Maximum Duty Cycle			92		%
Reference Voltage						
V _{FB}	Feedback Voltage		285	300	315	mV
MOSFET						
R _{ds (on)}	On resistance of MOSFET			1	2	
ILX	Current Limit		0.5	0.75	1.6	A
Control and Protection						
V _{EN1}	Shutdown Voltage		0.4	0.7		V
V _{EN2}	Enable Voltage			0.7	1.2	V
I _{EN}	EN Pin Pull Low Current			0.1	1	μA
OVP	OVP Threshold		37	38.5	40	V

Typical Operating Characteristic

Quiescent Current vs. VIN (Not Switching)

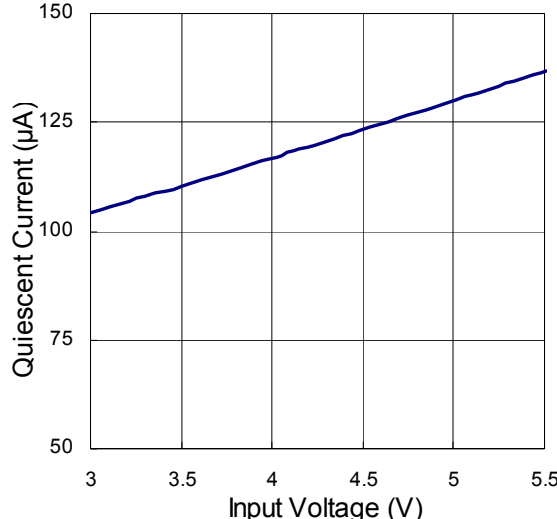

Quiescent Current vs. VIN (Switching)

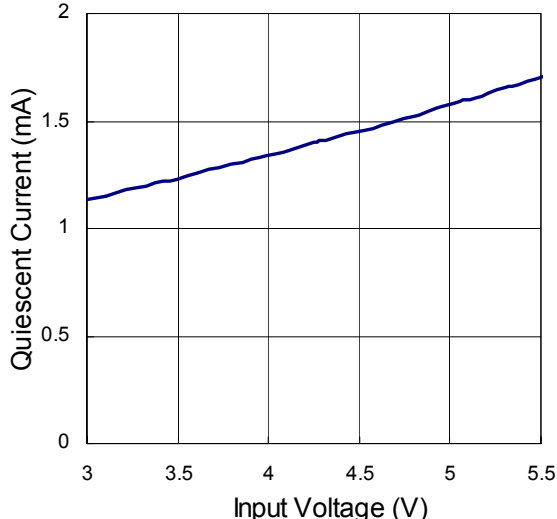

FB PIN Voltage vs. Temperature

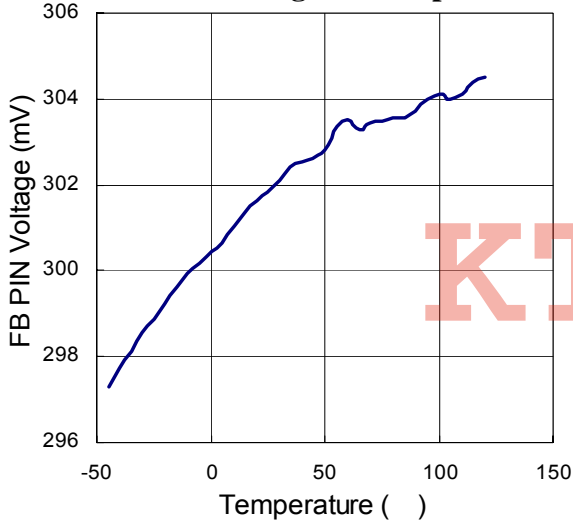

FB PIN Voltage vs. Output Current

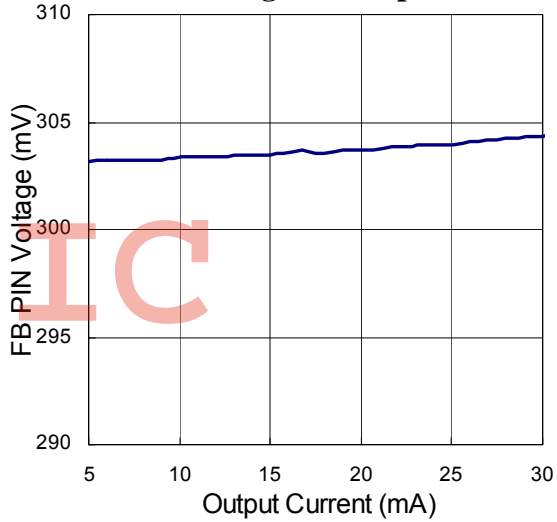

Switching Frequency vs. Supply Voltage

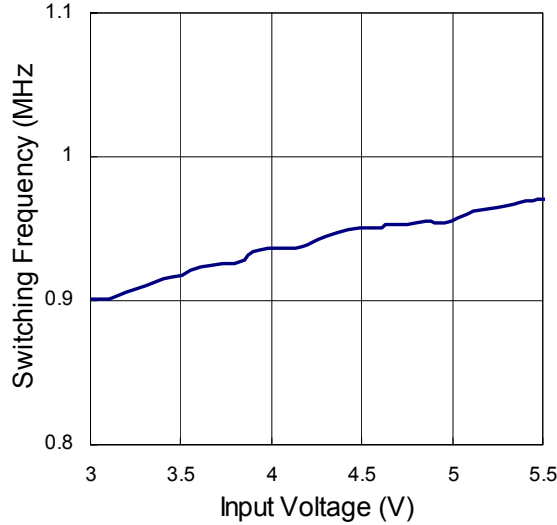

LED Current vs. Input Voltage

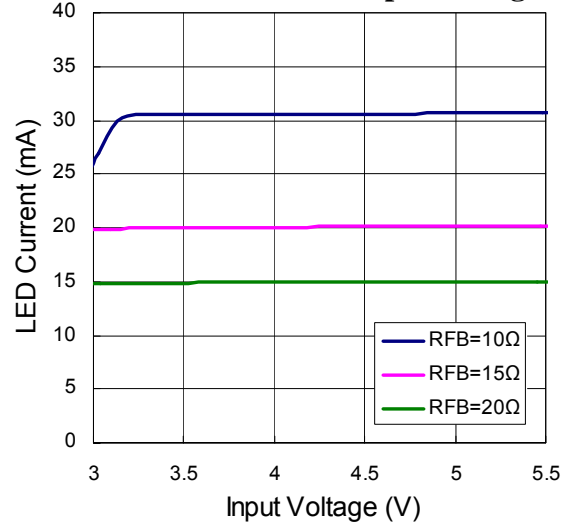

Typical Operating Characteristics (continued)

LED Current Regulation (10mA)

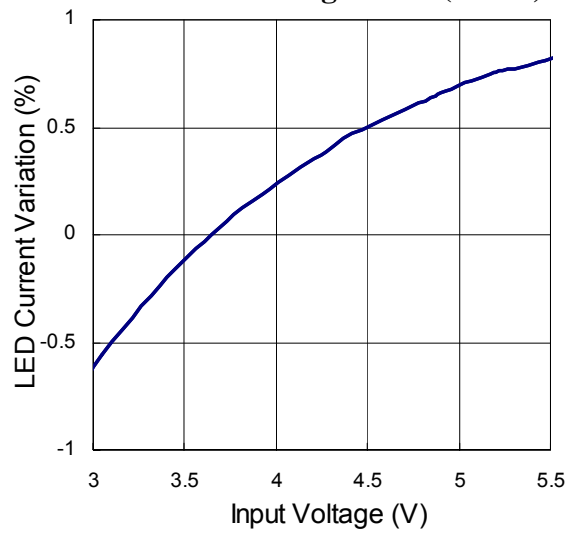

Efficiency vs. Load Current (10 LED)

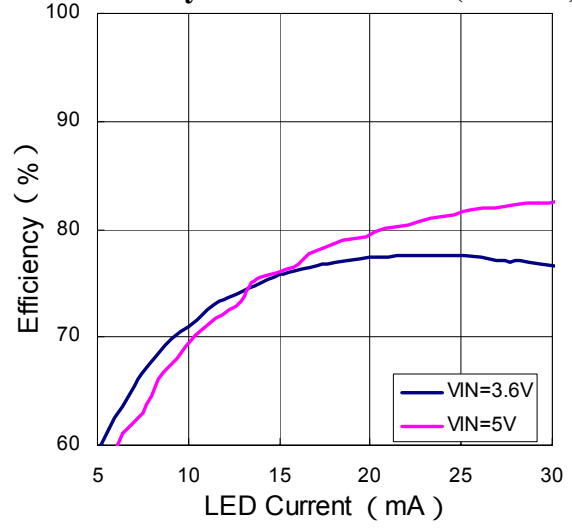

Efficiency vs. Input Voltage (10LED)

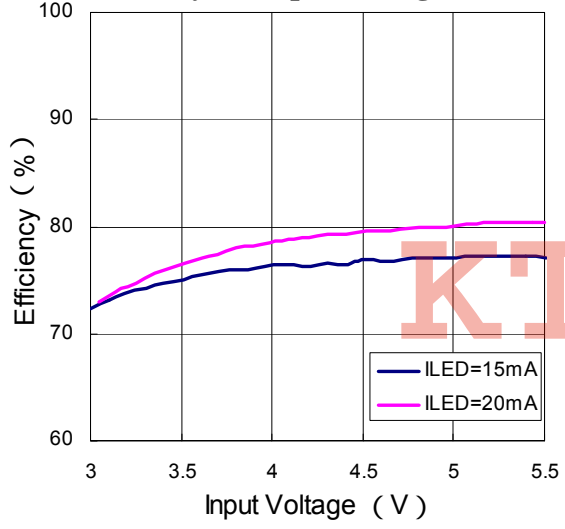

Switch On Resistance vs. Input Voltage

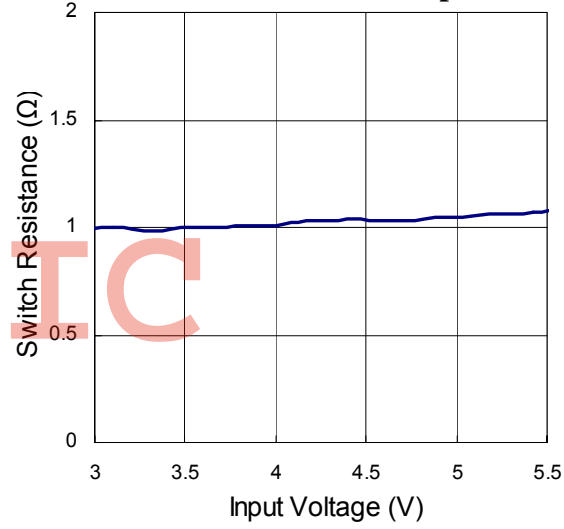

Maximum Output Current vs. Input Voltage

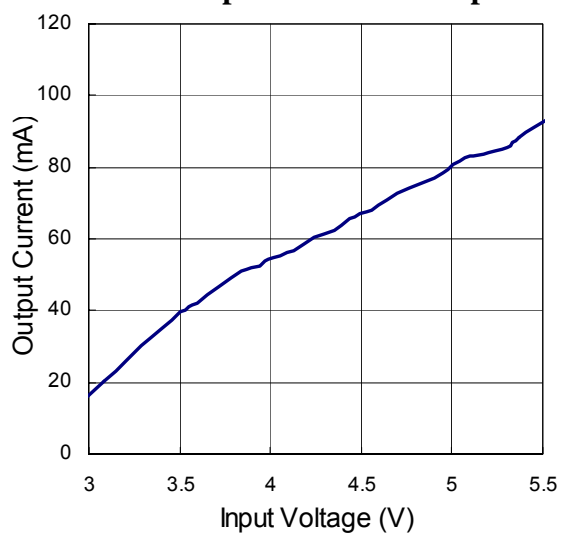

Shutdown Voltage vs. Input Voltage

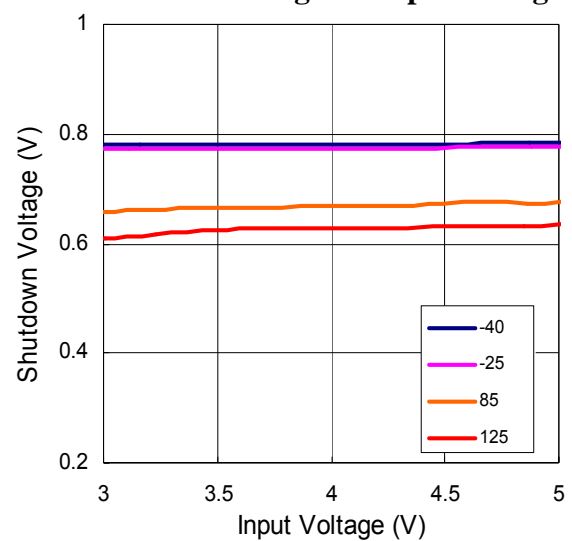

Typical Operating Characteristics (continued)

Open LED Supply Current vs. VIN

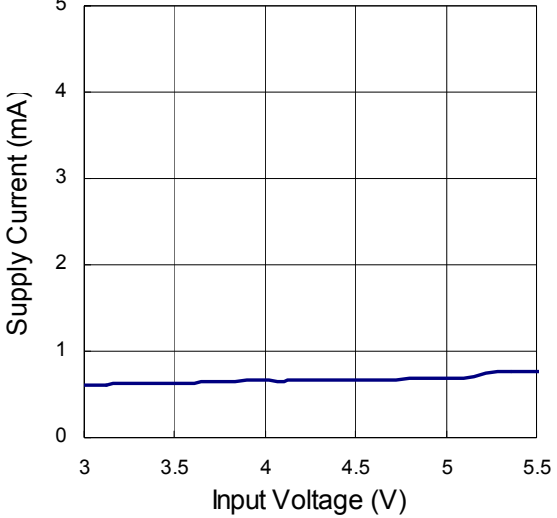

Light Load Switching Waveform
6LED, VIN=5.5V, ILED < 1mA, L=47μH

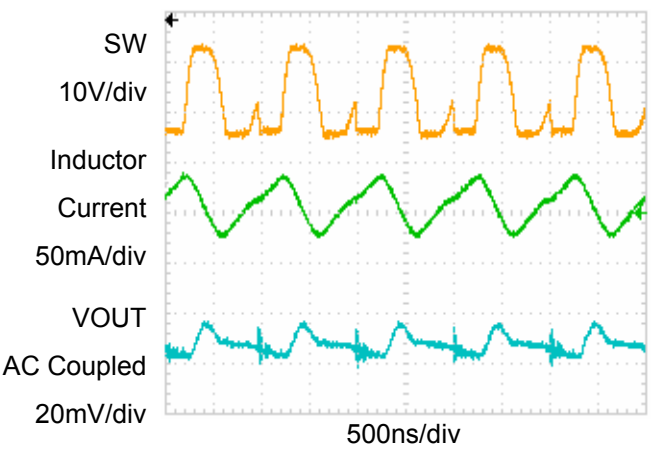

Typical Switching Waveforms

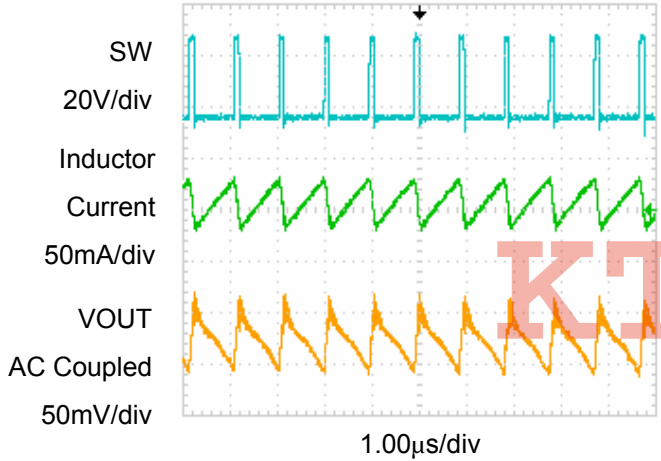

Power-up With 10 LEDs at 20mA

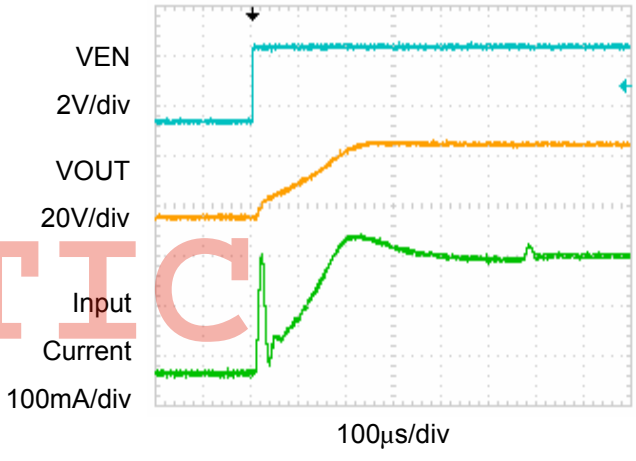

Enable to Open LED Waveforms

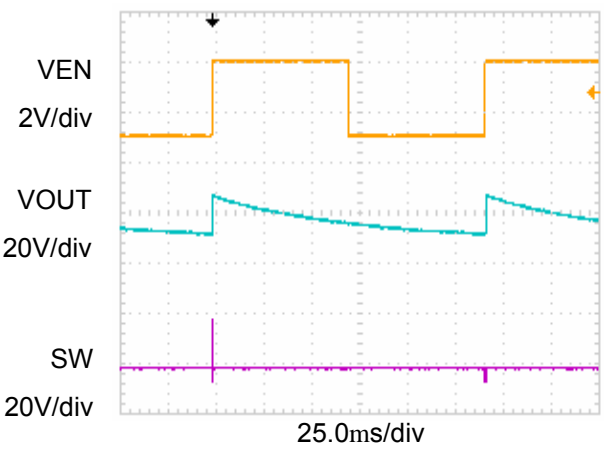

Enable to Open LED Waveforms

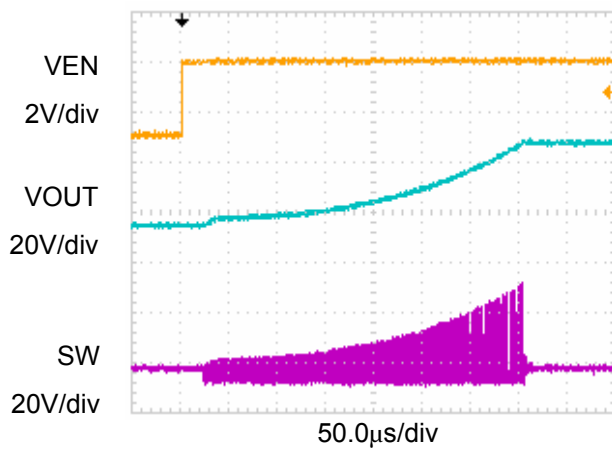

Application Information

LED Current Control

The EUP2539 regulates the LED current by setting the current sense resistor (R_{FB}) connecting to feedback and ground. The internal feedback reference voltage is 0.3V. The LED current can be set from following equation easily.

$$I_{LED} = \frac{0.3}{R_{FB}} \text{-----(1)}$$

In order to have an accurate LED current, precision resistors are preferred (1% is recommended). The table for R_{FB} selection is shown below.

R_{FB} Resistor Value selection

LED Current (mA)	R_{FB} (Ω)
5	60
10	30
15	20
20	15
25	12
30	10

Dimming Control

a. Using a PWM Signal to EN Pin

For controlling the LED brightness, the EUP2539 can perform the dimming control by applying a PWM signal to EN pin, and the PWM signal frequency range is from 100Hz to 100KHz. The average LED current is proportional to the PWM signal duty cycle. The magnitude of the PWM signal should be higher than the maximum enable voltage of EN pin, in order to let the dimming control perform correctly.

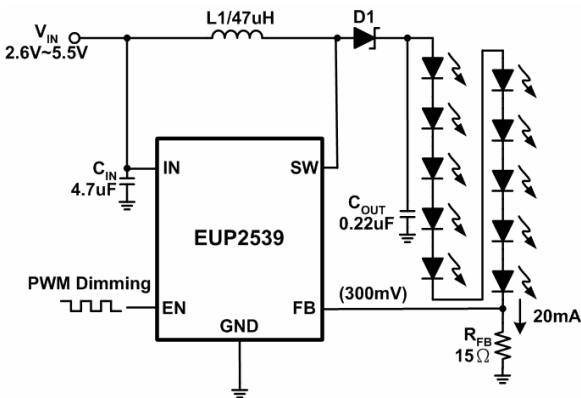

Figure 3. Direct PWM Dimming Control

Switching Waveform with 1kHz PWM on EN

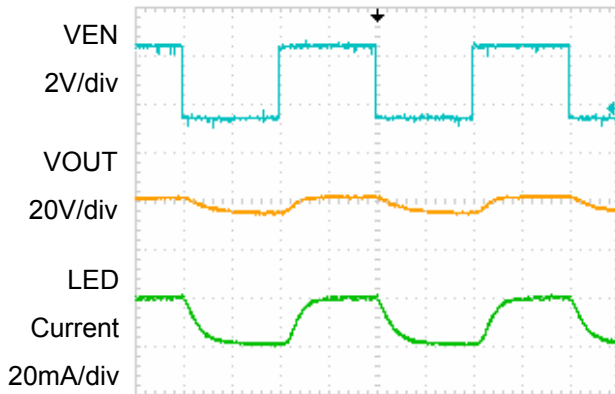

Figure 4.

b. Using a DC Voltage

Using a variable DC voltage to adjust the brightness is a popular method in some applications. The dimming control using a DC voltage circuit is shown in Figure 5. According to the Superposition Theorem, as the DC voltage increases, the voltage contributed to V_{FB} increases and the voltage drop on R_2 decreases, i.e. the LED current decreases. For example, if the V_{DC} range is from 0V to 2.8V, the selection of resistors in Figure 5 sets dimming control of LED current from 20mA to 0mA.

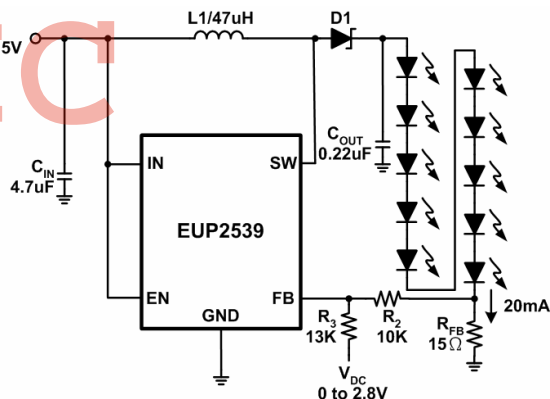

Figure 5. DC Voltage Dimming Control

c. Using a Filtered PWM Signal

Another common application is using a filtered PWM signal as an adjustable DC voltage for LED dimming control. A filtered PWM signal acts as the DC voltage to regulate the output current. The recommended application circuit is shown in the Figure 6. In this circuit, the output ripple depends on the frequency of PWM signal. For smaller output voltage ripple (<100mV), the recommended frequency of 2.8V PWM signal should be above 2kHz. To fix the frequency of PWM signal and change the duty cycle of PWM signal can get different output current. According to the application circuit of Figure 6, output current is from 20.5mA to 5.5mA by adjusting the PWM duty cycle from 10% to 90%.

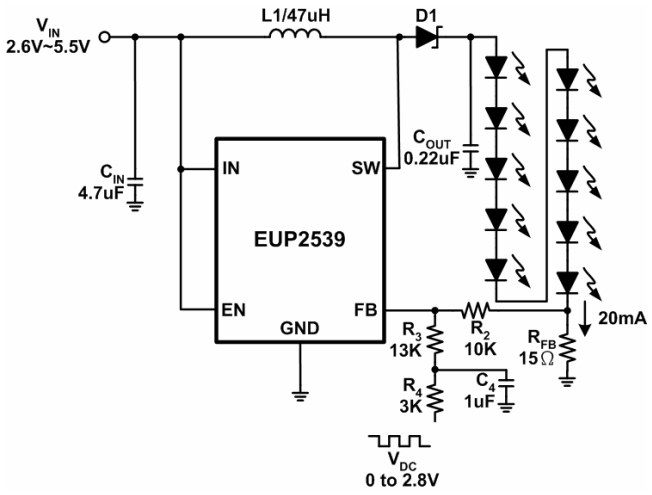

Figure 6. Filtered PWM Dimming Control

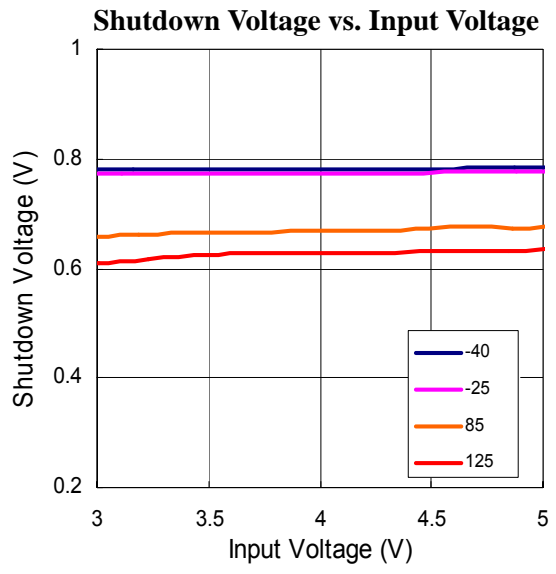

Figure 9.

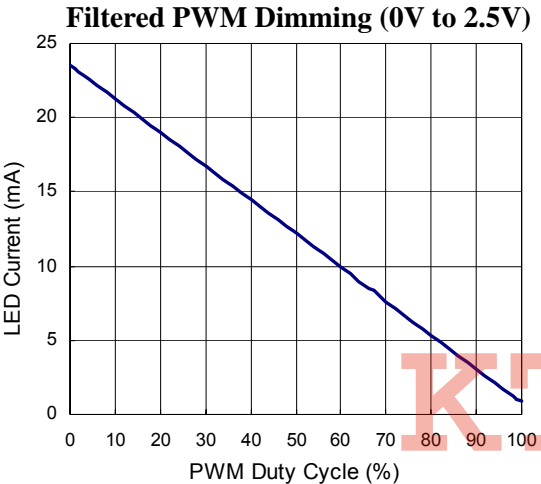

Figure 7.

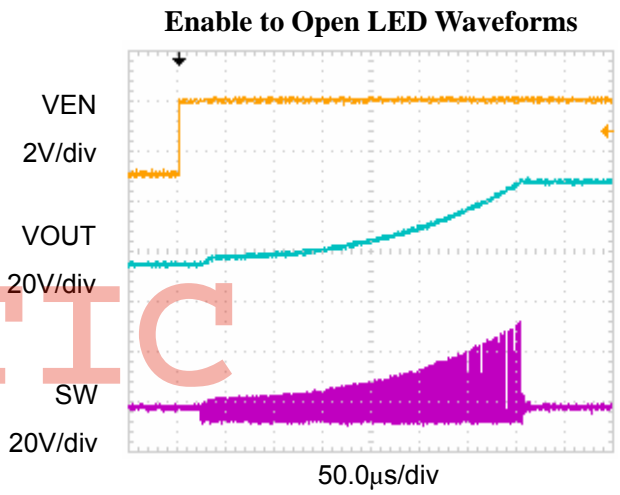

Figure 10.

Open Load Shutdown

In the event of an “Open LED” fault condition, the EUP2539 will continue to boost the output voltage with maximum power until the output voltage reaches approximately 38V. Once the output exceeds this level, the device will cease operation until the EN pin is cycled off and on.

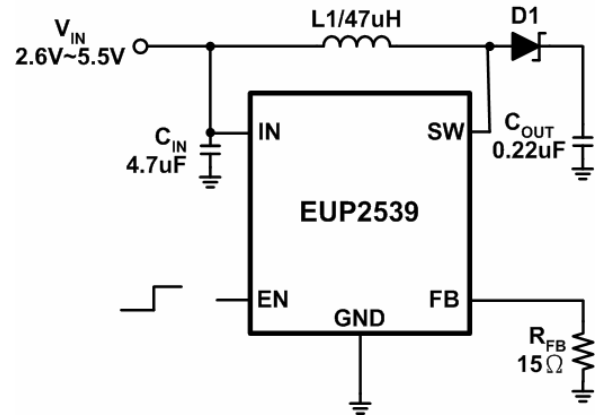

Figure 8. Open LED Protection

Thermal Shutdown

Thermal overload protection circuitry has been included to prevent the device from operating at unsafe junction temperatures above 150°C. In the event of a thermal overload condition the device will automatically shutdown and wait till the junction temperatures cools to 130°C before normal operation is resumed.

Capacitors Selection

A 4.7µF to 10µF ceramic input capacitor (C_{IN}) and a 0.22µF to 4.7µF ceramic output capacitor (C_{OUT}) are sufficient for most applications. During Direct PWM Dimming control, a larger output capacitor will significantly reduce audio noise induced by output capacitor, and a smaller will enlarge the audio noise, a 2.2µF C_{OUT} is recommended. Under normal condition, a 4.7µF input capacitor is sufficient. For applications with higher output power, a larger input capacitor of 10µF may be appropriate. X5R and X7R capacitor types are ideal due to their stability across temperature range.

Inductor Selection

The recommended value of inductor for 2 to 10 WLEDs applications are 4.7 μ H to 47 μ H. Small size and better efficiency are the major concerns for portable device, such as EUP2539 used for mobile phone. The inductor should have low core loss at 1MHz and low DCR for better efficiency. To avoid inductor saturation current rating should be considered.

Schottky Diode Selection

The current rating of the Schottky diode must exceed the peak current flowing through it. The Schottky diode performance is rated in terms of its forward voltage at a given current. In order to achieve the best efficiency, this forward voltage should be as low as possible. The response time is also critical since the driver is operating at 1MHz.

Board Layout

Careful PC board layout is required due to fast switching. All components must be placed as close to the device as possible. Keep the path between the inductor L1, diode D1, and output capacitor C_{OUT} extremely short for minimal noise and ringing. The feedback components such as the sense resistor R_{FB} must be kept close to the FB pin to prevent noise injection on the FB pin trace. The ground return of C_{IN} and C_{OUT} should be tied close to the GND pin. See the EUP2539 demo board layout for reference.

KTTIC

Packaging Information

TSOT23-5

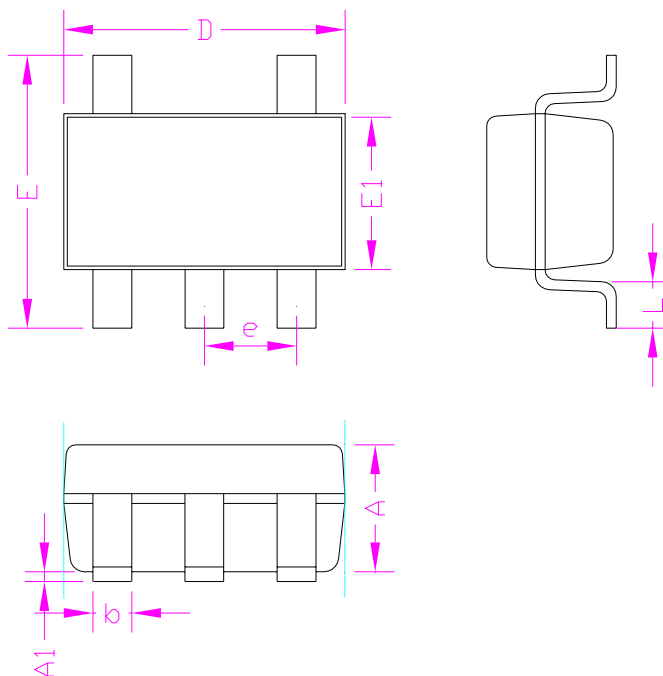

SYMBOLS	MILLIMETERS		INCHES	
	MIN.	MAX.	MIN.	MAX.
A	-	1.00	-	0.039
A1	0.00	0.15	0.000	0.006
D	2.90		0.114	
E1	1.60		0.063	
E	2.60	3.00	0.102	0.118
L	0.30	0.60	0.012	0.024
b	0.30	0.50	0.012	0.020
e	0.95		0.037	