



**EUTECH**  
MICROELECTRONICS

*EUP2584*

# White LED Step-Up Converter In Tiny SOT-23 Package

## DESCRIPTION

The EUP2584 is a constant current step-up converter specifically designed to drive white LEDs. The Step-up converter topology allows series connection of the white LEDs so the LED currents are identical for uniform brightness. The EUP2584 switches at 1.1MHz, allowing the use of tiny external components. The input and output capacitor can be as small as 1µF, saving space and cost versus alternative solutions. A low 0.25V feedback voltage minimizes power loss in the current setting resistor for better efficiency. EUP2584 is enhanced with Soft-Start function and that could significantly reduce noise induced by capacitor.

The EUP2584 is available in low profile SOT23-6 package.

## FEATURES

- 2.6V to 5.5V Input Range
- 27V Output with Over Voltage Protection
- High Efficiency :85 % Typical
- Internal Soft-Start
- PWM Dimming Control
- Internal High Power 30V MOSFET Switch
- Fast 1.1MHz Switching Frequency
- Small, Low-Profile Inductors and Capacitors
- SOT23-6 Package
- RoHS Compliant and 100% Lead (Pb)-Free

## APPLICATIONS

- Mobile Phone
- Digital Still Camera
- PDAs, Handheld Computers
- MP3 Players
- GPS Receivers



## Typical Application Circuit

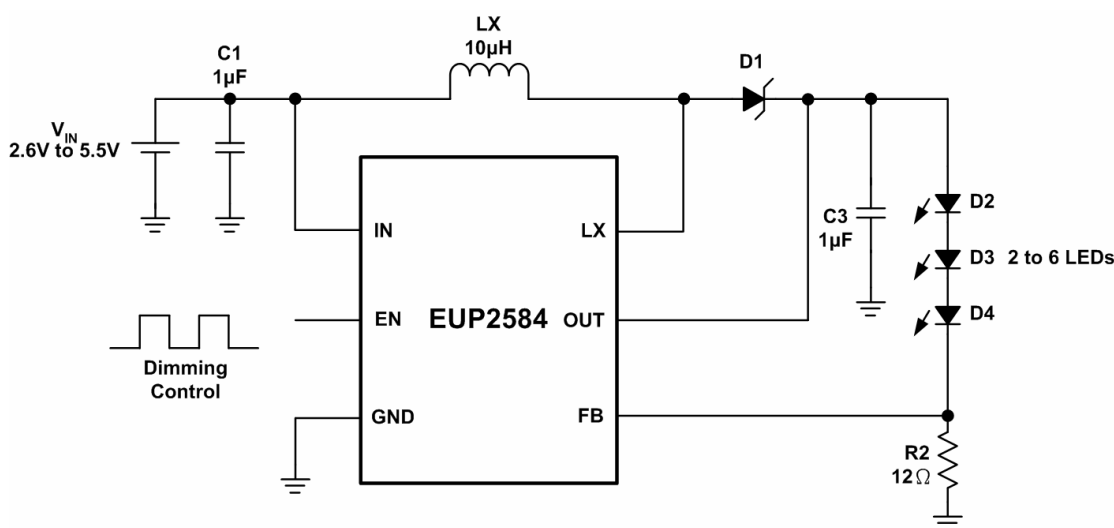

Figure 1. White LED Application

**Pin Configurations**

Package Type	Pin Configurations
SOT23-6	

**Pin Description**

PIN	SOT23-6	DESCRIPTION
LX	1	Switch Pin. Connect inductor/diode here. Minimize trace area at this pin to reduce EMI.
GND	2	Common Ground
FB	3	Feedback Pin. Reference voltage is 0.25V. Connect cathode of lowest LED and resistor here. Calculate resistor value according to the formula: $R_{FB} = 0.25 / I_{LED}$
EN	4	Chip Enable Pin. Connect to 1.4V or higher to enable device, 0.3V or less to disable device.
IN	6	Input Supply Voltage
OUT	5	Overvoltage Sense. When $V_{OUT}$ is greater than 27V, the internal N-channel MOSFET turns off until $V_{OUT}$ drops below 25V, then the IC reenters start. Connect a 1uF capacitor from OUT to GND.

**Ordering Information**

Order Number	Package Type	Marking	Operating Temperature range
EUP2584VIR1	SOT23-6	q0	-40 °C to 85°C

EUP2584

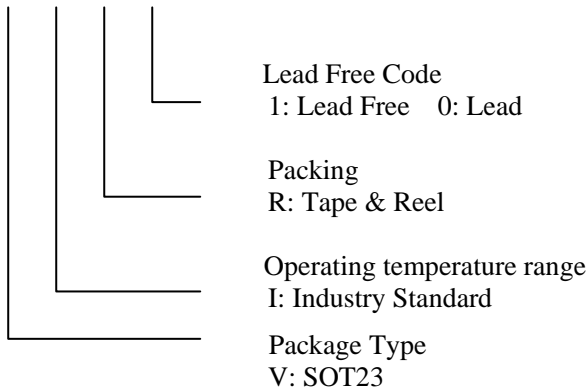

**Block Diagram**

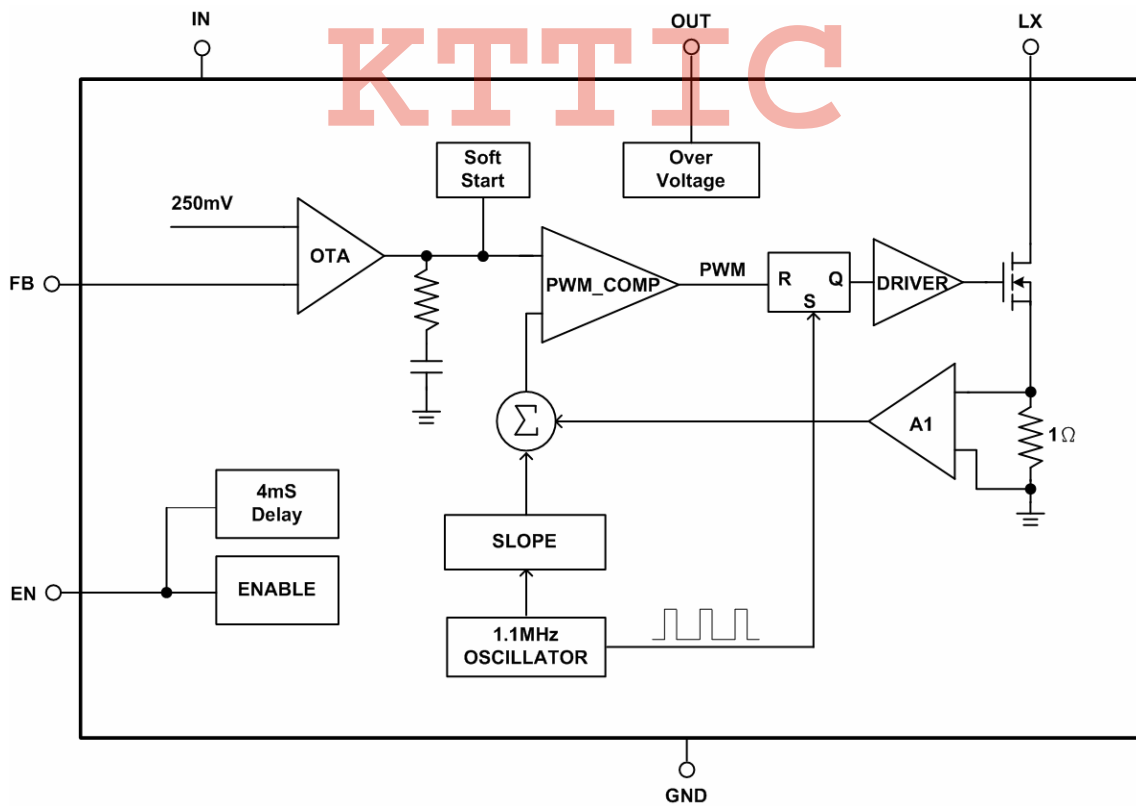

Figure 2.

**Absolute Maximum Ratings**

- Supply Voltage,  $V_{IN}$  ----- -0.3V to 6V
- LX,OUT ----- -0.3V to 30V
- The Other Pins ----- -0.3V to 6V
- Power dissipation,  $P_D @ T_A=25^\circ C$   
SOT23-6 ----- 0.4W
- Package Thermal Resistance  
SOT23-6,  $J_A$  ----- 250°C/W
- Maximum Junction Temperature ----- 125°C
- Lead Temperature (Soldering, 10sec.) ----- 260°C
- Storage Temperature Range ----- -65°C to 150°C

**Operating Conditions**

- Junction Temperature Range ----- -40°C to 125°C
- Supply Voltage,  $V_{IN}$  ----- 2.6V to 5.5V

**Electrical Characteristics**

( $V_{IN}=3.6V$ ,  $V_{OUT}=18V$ ,  $C_{OUT}=1\mu F$ ,  $C_{IN}=1\mu F$ ,  $R_{SENSE}=12\ \Omega$ ,  $T_A=-40^\circ C$  to  $85^\circ C$ . Unless otherwise noted.  
Typical values are at  $T_A=25^\circ C$ )

Symbol	Parameter	Conditions	EUP2584			Unit
			Min	Typ	Max.	
	Supply Voltage		--	--	6	V
UVLO	Under Voltage Lock Out	$V_{IN}$ Rising	2.2	2.4	2.6	V
		$V_{IN}$ Falling	1.95	2.15	2.35	
	Maximum Output Voltage	No Switching	--	--	30	V
$I_{CC1}$	Supply Current	$V_{CC}=6V$ , Continuous Switching	--	0.8	1.3	mA
$I_{CC2}$	Quiescent Current	$V_{CC}=6V$ , $FB=1.3V$ , No Switching	--	115	150	$\mu A$
$I_{CC3}$	Shutdown current	$V_{CC}=6V$ , $V_{EN}<0.3V$	--	0.1	1	$\mu A$
<b>Oscillator</b>						
Fosc	Operation Frequency		0.8	1.1	1.3	MHz
Dmax	Maximum Duty Cycle		89	92	96	%
<b>Reference Voltage</b>						
$V_{FB}$	Feedback Voltage		230	250	270	mV
<b>MOSFET</b>						
Rds (on)	On resistance of MOSFET		--	1	1.5	
ILX	Current Limit		0.4	0.8	1.2	A
<b>Control and Protection</b>						
$V_{EN1}$	Shutdown Voltage		0.3	0.7	--	V
$V_{EN2}$	Enable Voltage		--	0.7	1.4	V
$I_{EN}$	EN Pin Pull Low Current		--	--	0.1	$\mu A$
OVP	OVP Threshold	Falling	24.5	25.7	26.5	V
		Rising	26.1	27.3	28.1	

Typical Operating Characteristics

Efficiency vs.  $V_{in}$  (Driving 1WLED)

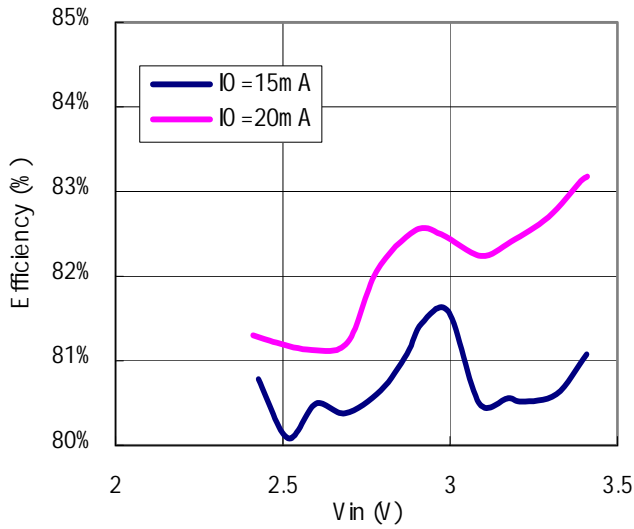

Efficiency vs.  $V_{IN}$  (Driving 3WLEDs)

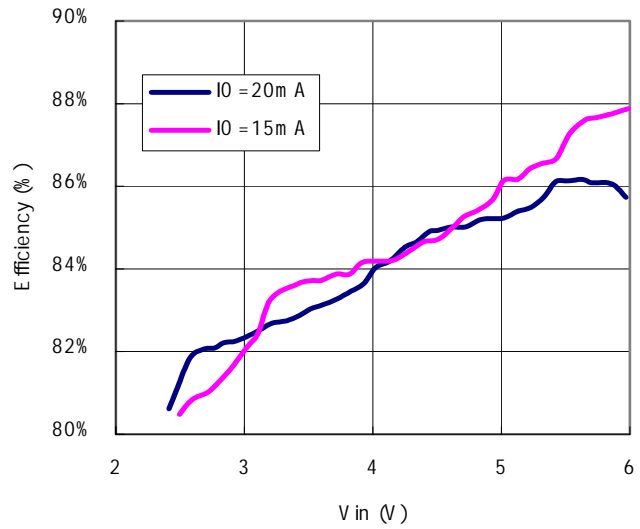

Efficiency vs.  $V_{IN}$  (Driving 6WLEDs)

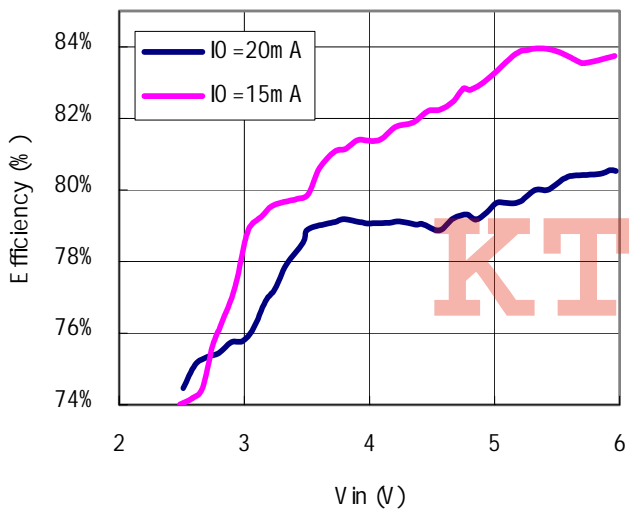

$V_{IN}=2.6V$  Driving 2LEDs Stability

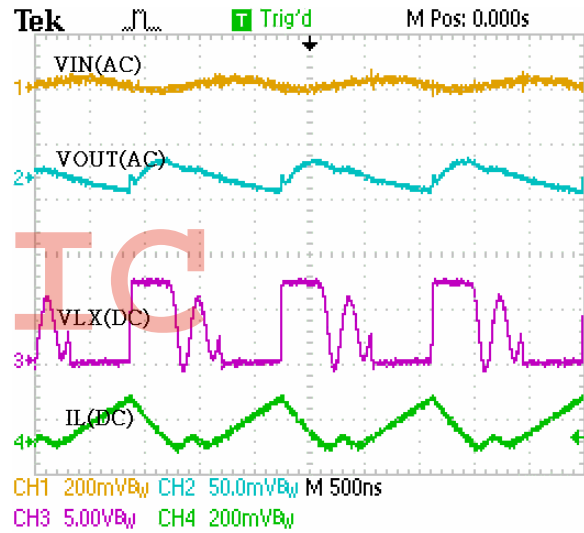

$V_{IN}=3.6V$  Driving 2LEDs Stability

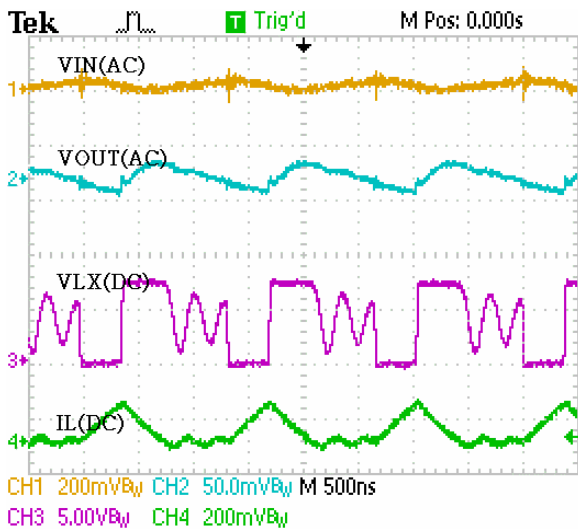

$V_{IN}=5V$  Driving 2LEDs Stability

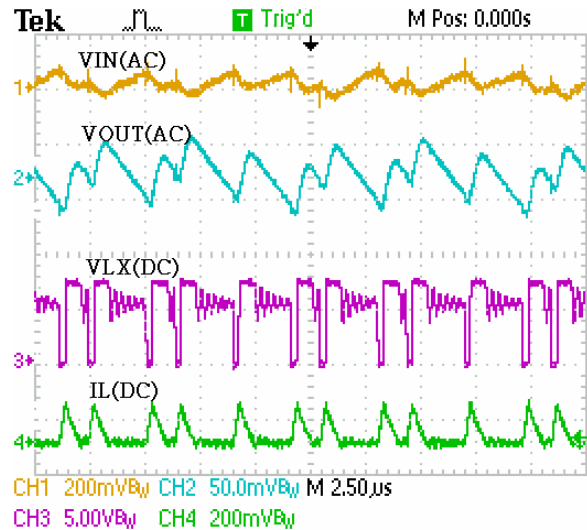

**V<sub>IN</sub>=2.6V Driving 4LEDs Stability**

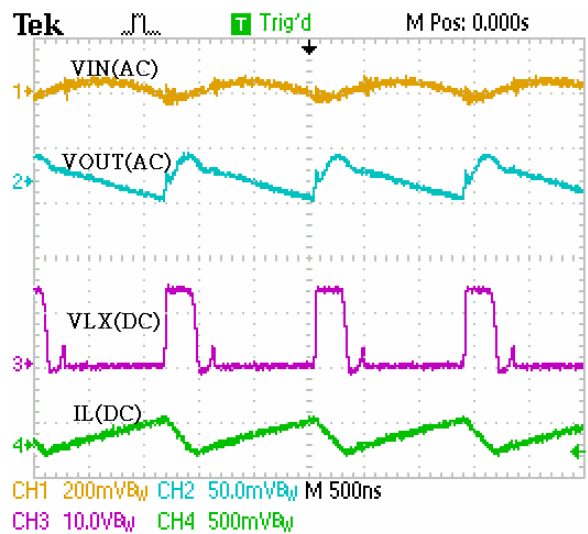

**V<sub>IN</sub>=3.6V Driving 4LEDs Stability**

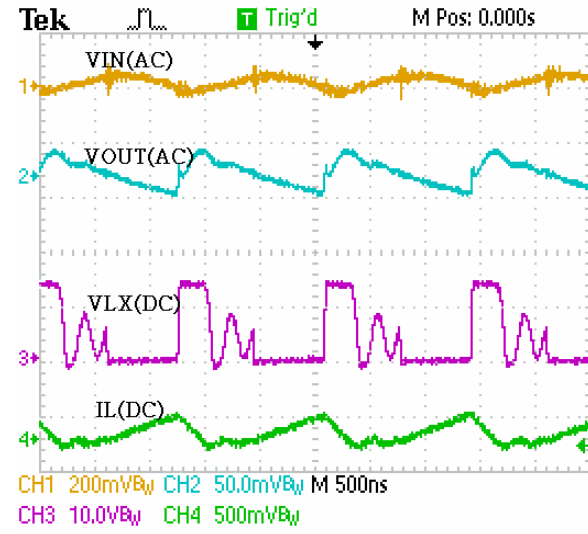

**V<sub>IN</sub>=5V Driving 4LEDs Stability**

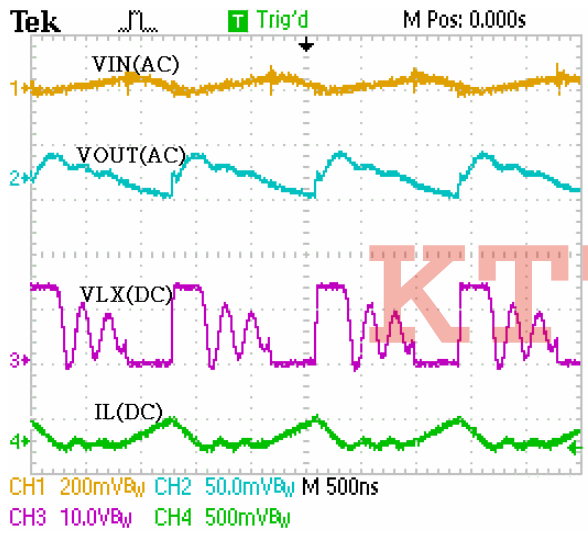

**V<sub>IN</sub>=2.6V Driving 6LEDs Stability**

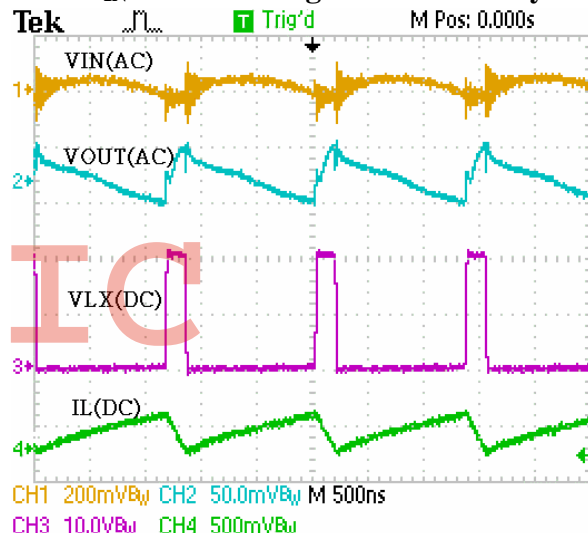

**V<sub>IN</sub>=3.6V Driving 6LEDs Stability**

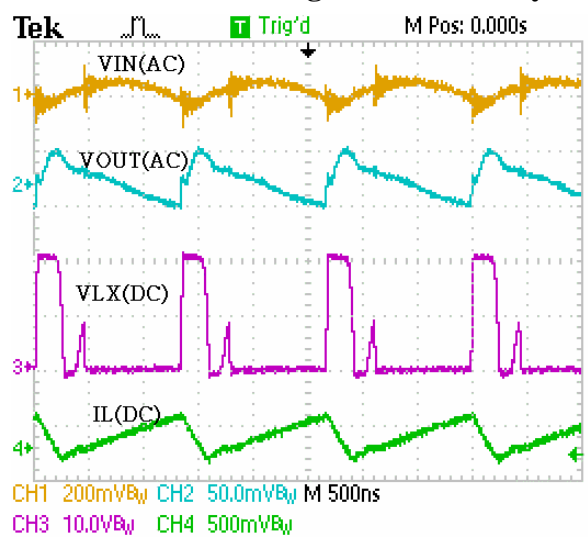

**V<sub>IN</sub>=5V Driving 6LEDs Stability**

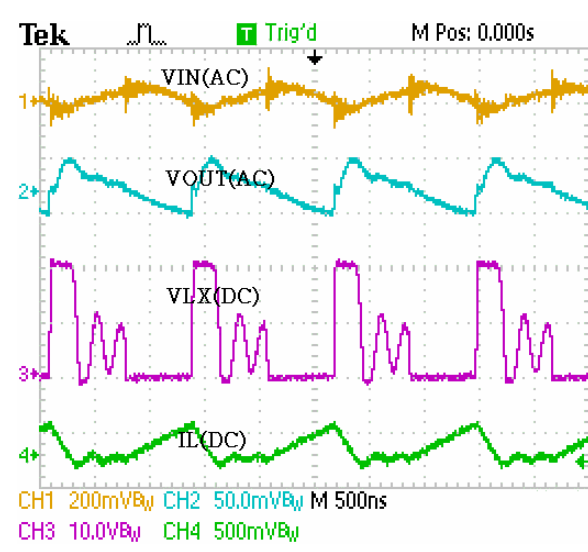

$V_{IN}=3.6V$  Driving 2LEDs Inrush Current

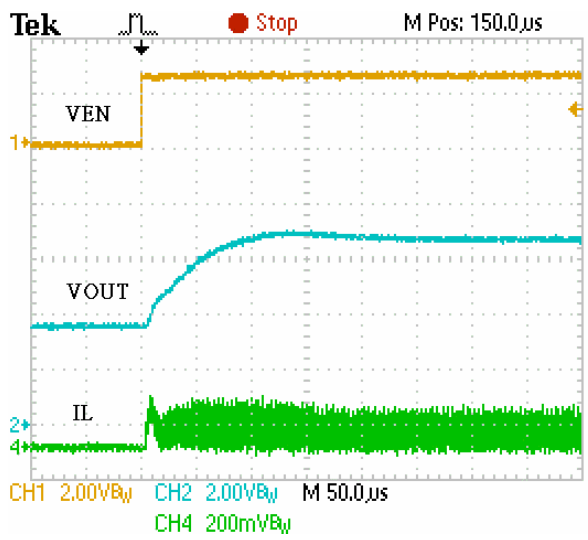

$V_{IN}=3.6V$  Driving 4LEDs Inrush Current

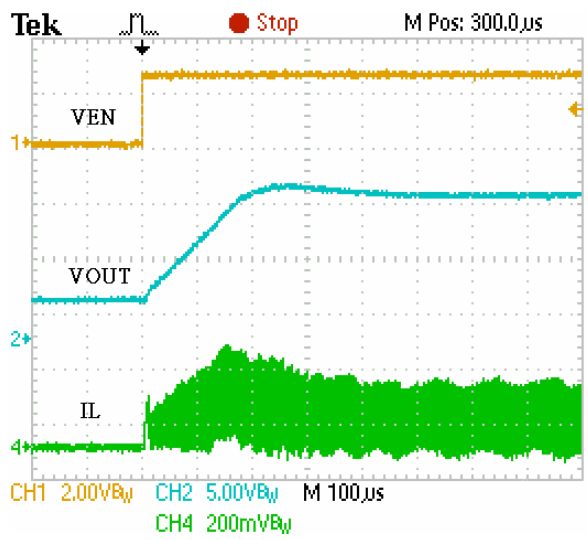

$V_{IN}=3.6V$  Driving 6LEDs Inrush Current

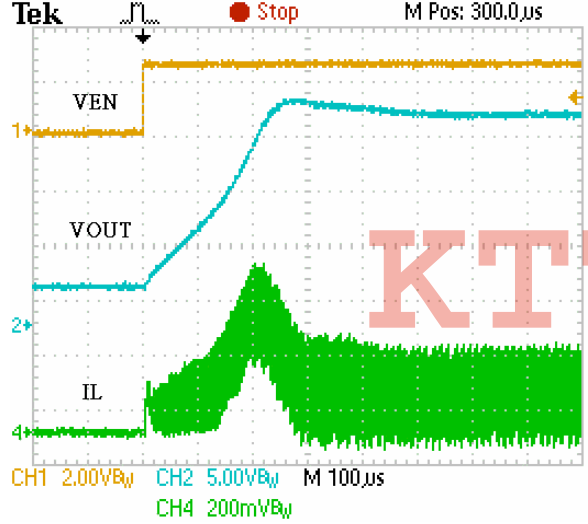

$V_{IN}=3.6V$  Driving 6LEDs 100Hz PWM Dimming

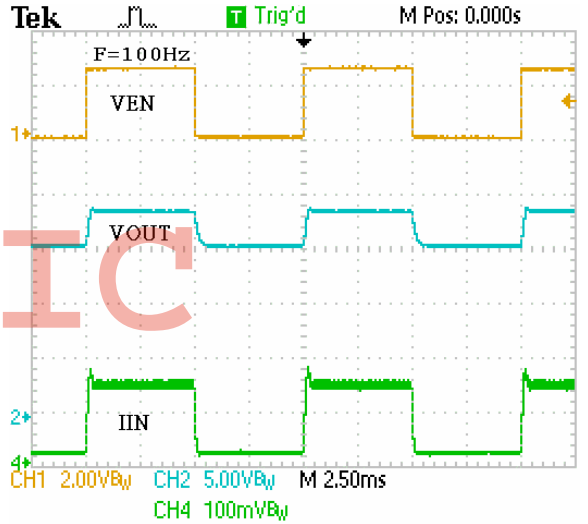

$V_{IN}=3.6V$  Driving 6LEDs 1KHz PWM Dimming

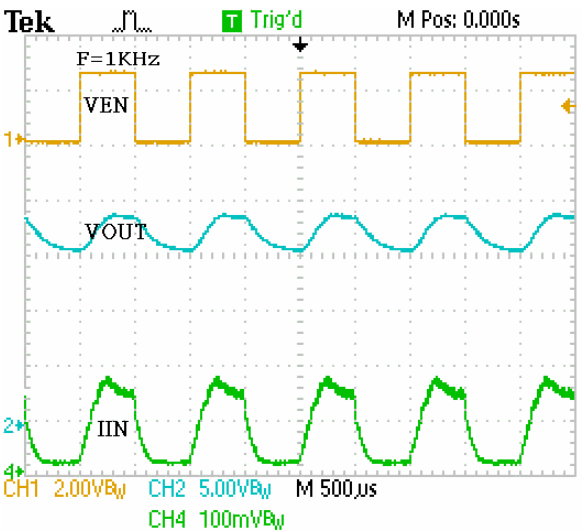

$V_{IN}=3.6V$  Driving 6LEDs 10KHz PWM Dimming

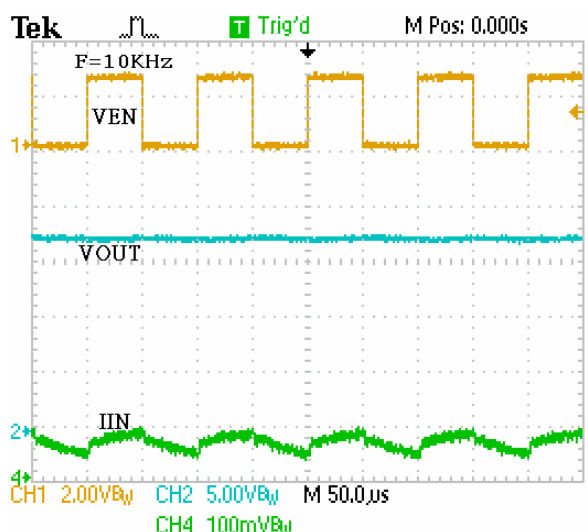

**$V_{IN}=3.6V$  Driving 6LEDs 100KHz PWM Dimming**

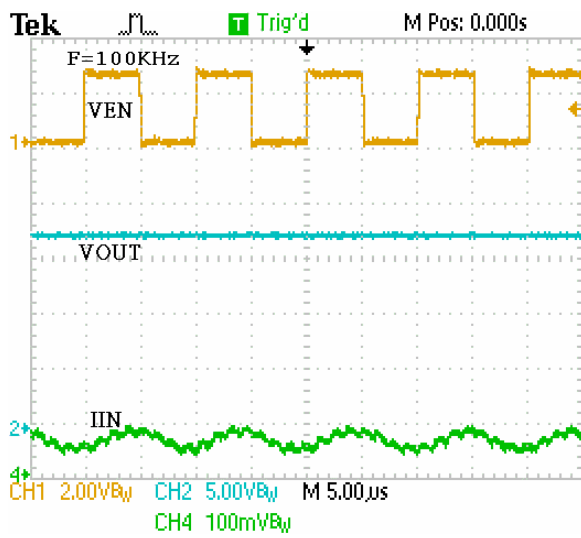

KTTIC



**Application Information**

**LED Current Control**

The EUP2584 regulates the LED current by setting the current sense resistor (R2) connecting to feedback and ground. The internal feedback reference voltage is 0.25V. The LED current can be set from following equation easily.

$$R2 = 0.25V / I_{LED} \text{-----(1)}$$

In order to have an accurate LED current, precision resistors are preferred (1% is recommended). The table for R2 selection is shown below.

R2 Resistor Value selection

I <sub>LED</sub> (mA)	R2 ( )
5	50
10	25
12	21
15	16.7
20	12.5

**Inductor Selection**

The recommended value of inductor for 2 to 6 WLEDs applications are 4.7 to 22μH. Small size and better efficiency are the major concerns for portable device, such as EUP2584 used for mobile phone. The inductor should have low core loss at 1.1MHz and low DCR for better efficiency. To avoid inductor saturation current rating should be considered.

**Dimming Control**

a. Using a PWM Signal to EN Pin

For controlling the LED brightness, the EUP2584 can perform the dimming control by applying a PWM signal to EN pin. The internal soft-start and wide range dimming frequency from 100Hz to 100KHz can insignificantly reduce audio noise when dimming. The average LED current is proportional to the PWM signal duty cycle. The magnitude of the PWM signal should be higher than the maximum enable voltage of EN pin, in order to let the dimming control perform correctly.

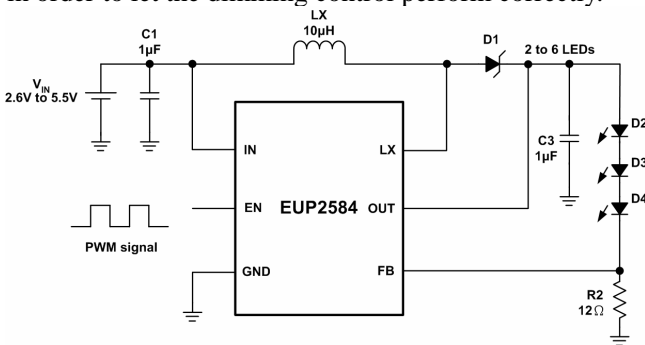

**Figure 3. PWM Dimming Control Using the EN Pin**

b. Using a DC Voltage

Using a variable DC voltage to adjust the brightness is a popular method in some applications. The dimming control using a DC voltage circuit is shown in Figure 4. According to the Superposition Theorem, as the DC voltage increases, the voltage contributed to V<sub>FB</sub> increases and the voltage drop on R2 decreases, i.e. the LED current decreases. For example, if the V<sub>DC</sub> range is from 0V to 2.8V, the selection of resistors in Figure 4 sets dimming control of LED current from 20mA to 0mA.

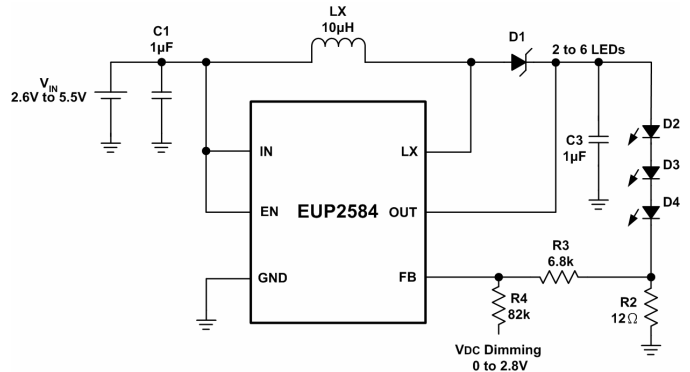

**Figure 4. Dimming Control Using a DC Voltage**

c. Using a Filtered PWM signal

Another common application is using a filtered PWM signal as an adjustable DC voltage for LED dimming control. A filtered PWM signal acts as the DC voltage to regulate the output current. The recommended application circuit is shown in the Figure 6. In this circuit, the output ripple depends on the frequency of PWM signal. For smaller output voltage ripple (<100mV), the recommended frequency of 2.8V PWM signal should be above 2kHz. To fix the frequency of PWM signal and change the duty cycle of PWM signal can get different output current. According to the application circuit of Figure 5, output current is from 20.5mA to 5.5mA by adjusting the PWM duty cycle from 10% to 90%.

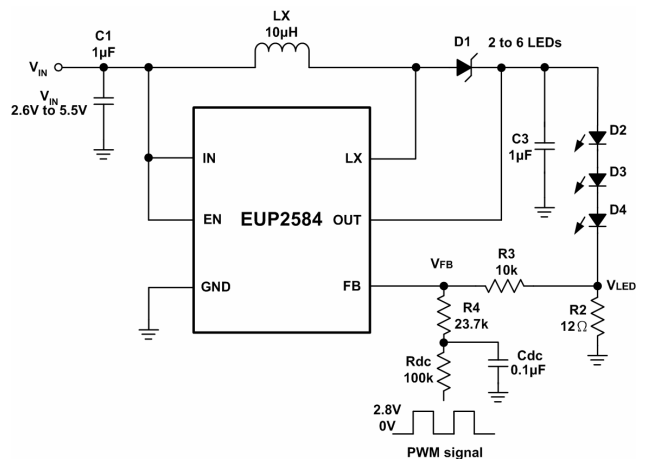

**Figure 5. Filtered PWM Signal for LED Dimming Control**

**Constant Output Voltage for Backlight of Main Panel and Flashlight**

Figure 6 is an application of EUP2584 for backlight of main panel and flashlight. Setting the divider-resistors (R1 & R2) is to get a constant output voltage that depends on the forward voltage and the numbers of series-LEDs. There are three kinds of mode controlled by the switches - backlight mode /flashlight mode /backlight + flashlight mode. It can turn on backlight or flashlight at one time or both at the same time. Applying different duty cycle of PWM signal above 22kHz to backlight's switch can also control the brightness. The following formula (2)(3) can determine R3 and R4.

$$R3 = \frac{V_{OUT} - 3V_{Fb} - V_{DS}}{I_b} \text{-----(2)}$$

$$R4 = \frac{V_{OUT} - 3V_{Ff} - V_{DS}}{I_f} \text{-----(3)}$$

$$V_{DS} = I_b \times R_{DS(ON)} \text{-----(4)}$$

**Constant Output Voltage for Backlight of Main Panel and Keypad**

Figure 7 is another application of EUP2584 for backlight and keypad. Setting the divider-resistors (R1 & R2) is to get a constant output voltage that depends on the forward voltage and the numbers of series-LEDs. It can turn on backlight of main panel and keypad at the same time. Applying different duty cycle of PWM signal above 22kHz to the backlight's switch can also control the brightness of main panel's backlight. The keypad's backlight will keep the same brightness during the dimming control of main panel. Otherwise the brightness of keypad's s backlight can also change during the dimming control of main panel by using the application circuit as figure 4. The following formula (5)(6) can determine the resistors of Figure 8.

$$R3 = \frac{V_{OUT} - 3V_{Fb} - V_{DS}}{I_b} \text{-----(5)}$$

$$R4 = R5 = R6 = \frac{V_{OUT} - 3V_{Fk}}{I_k} \text{-----(6)}$$

$$V_{DS} = I_b \times R_{DS(ON)} \text{-----(7)}$$

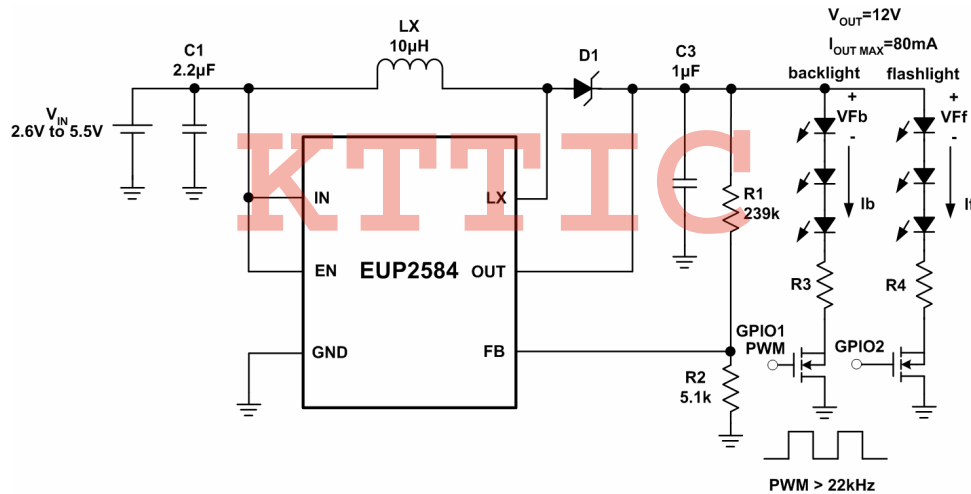

**Figure 6. Constant Output Voltage for Backlight and Flashlight**

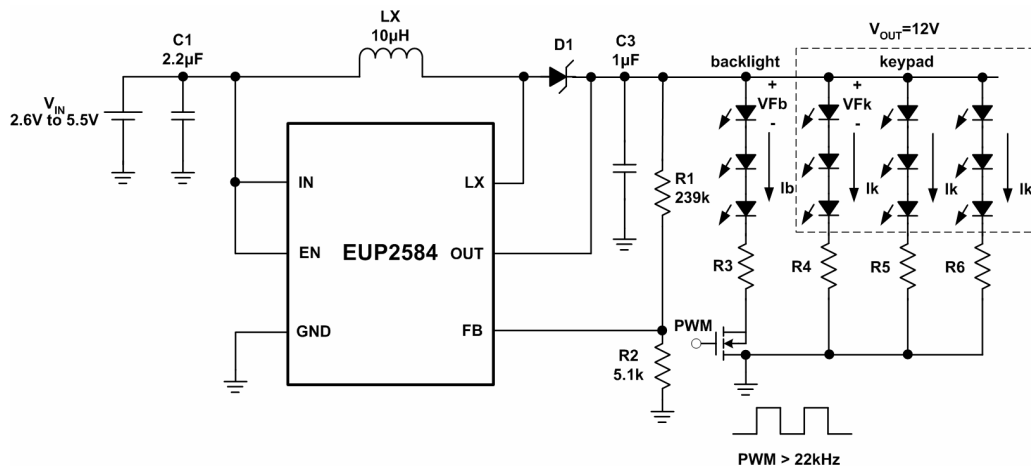

**Figure 7. Constant Output Voltage for Backlight and Keypad**

Packaging Information

SOT23-6

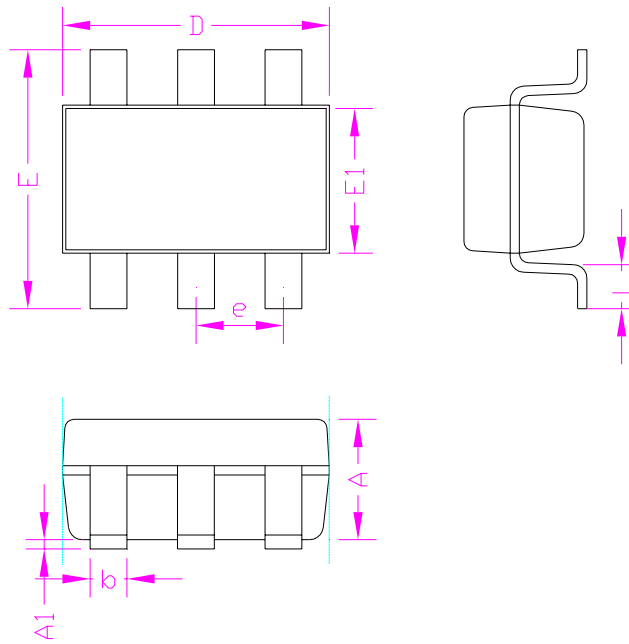

KTTIC

SYMBOLS	MILLIMETERS		INCHES	
	MIN.	MAX.	MIN.	MAX.
A	-	1.45	-	0.057
A1	0.00	0.15	0.000	0.006
b	0.30	0.50	0.012	0.020
D	2.90		0.114	
E1	1.60		0.063	
e	0.95		0.037	
E	2.60	3.00	0.102	0.118
L	0.3	0.60	0.012	0.024