



EUTECH
MICROELECTRONICS

EUP8051A

Low Cost 1A Linear Battery Charge Controllers

DESCRIPTION

The EUP8051A is a single Lithium-Ion (Li-Ion) and Lithium-Polymer (Li-Pol) linear charge management controller for use in cost sensitive and portable applications. It combines high accuracy constant-current and constant-voltage regulation, cell preconditioning, temperature monitoring, automatic charge termination, charge-status indication, in a space-saving MSOP-8 package.

The EUP8051A applies a constant current up to 1A to the battery and the charge current can be programmed externally with a sense-resistor.

The EUP8051A automatically terminates the charge cycle when the charge current drops to the charge termination threshold (I_{TERM}) after the charge-regulation voltage is reached.

When the input supply is removed, the EUP8051A automatically enters a low-power sleep mode, dropping the battery drain current to less than $1\mu A$.

A battery charge state output pin is provided to indicate battery charge status through a display LED. The battery charge status output is a serial interface which may also be read by a system microcontroller.

FEATURES

- Programmable Charge Current up to 1A
- 4.5V-7V Input Voltage Range
- Ideal for Single Cell (4.2V) Li-Ion or Li-Pol Batteries
- Preset Charge Voltage with $\pm 1\%$ Accuracy
- Constant-Current/Constant Voltage Operation
- Preconditioning of Low Voltage Cells
- Optional Cell-Temperature Monitoring Before and During Charge
- Charge Status Indication
- Automatic Battery Recharge
- Charge Termination by Minimum Current
- Automatic Low-Power Sleep Mode When Input Power is Removed
- Available in MSOP-8 Package
- RoHS Compliant and 100% Lead (Pb)-Free

APPLICATIONS

- Cellular Phones / PDAs/ MP3 Players/DSC
- Handheld Instruments

Typical Application Circuit

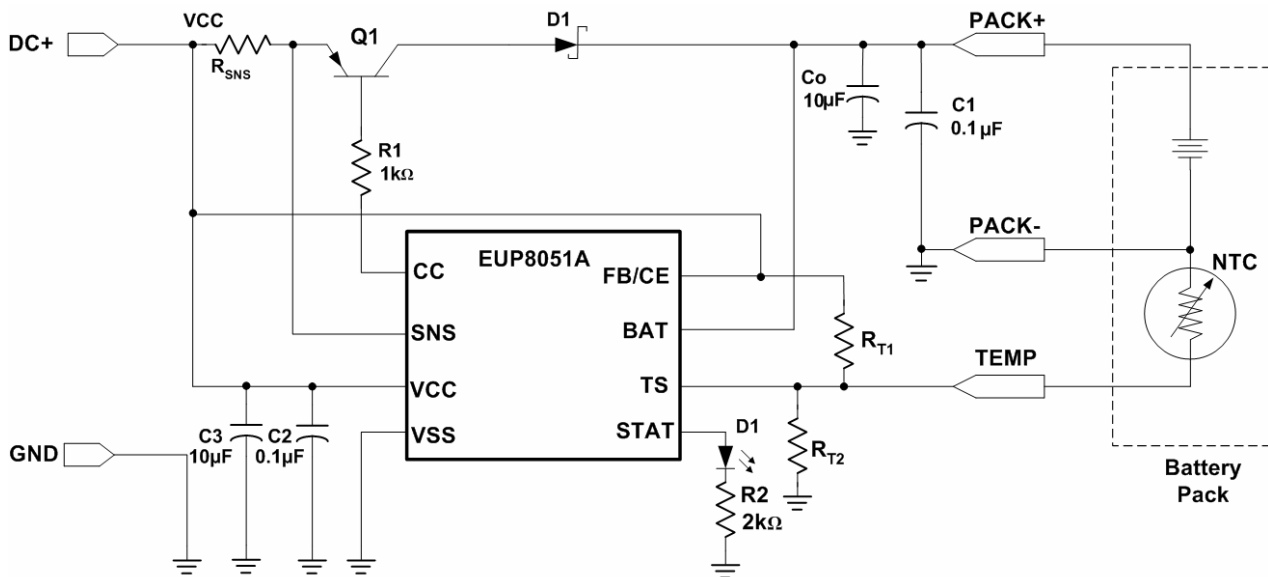

Figure1. Linear Charger Using PNP Transistor

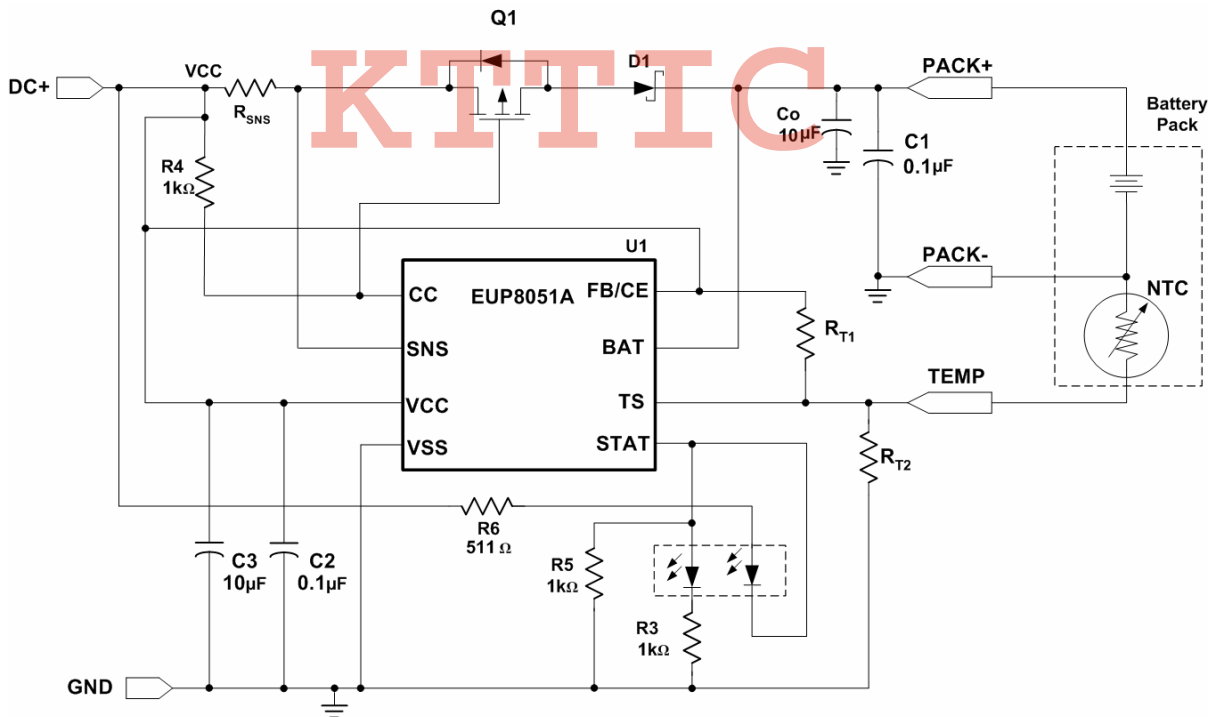

Figure2. Linear Charger Using P-Channel MOSFET

Pin Configurations

Part Number	Pin Configurations
EUP8051A MSOP-8	<p>VCC 1 8 BAT TS 2 7 SNS STAT 3 6 FB/CE VSS 4 5 CC</p>

Pin Description

PIN	MSOP-8	I/O	DESCRIPTION
VCC	1	I	Supply Voltage Input
TS	2	I	Temperature Sense Input
STAT	3	O	Charge Status Output
VSS	4		Ground
CC	5	O	Charge Control Output
FB/CE	6	I	External Feedback input or Charge Enable Function. Input from controller or finely adjust the battery regulated voltage with external voltage divider
SNS	7	I	Current Sense Input
BAT	8	I	Battery Voltage Input

Ordering Information

Order Number	Package Type	Marking	Operating Temperature range
EUP8051A-42MIR1	MSOP-8	XXXX 8051A	-20 °C to 70°C

EUP8051A-

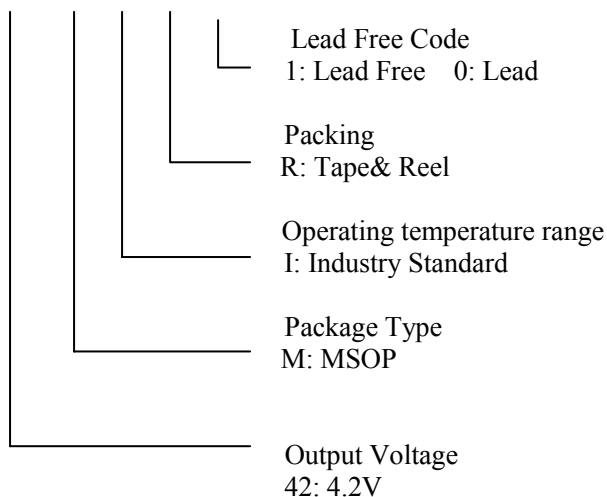

KTTIC

Absolute Maximum Ratings

- Supply voltage, (V_{CC} with respect to GND) ----- -0.3 to +10V
- Input voltage, SNS, BAT, TS, PI (all with respect to GND)----- -0.3V to V_{CC}+0.3V
- Sink current (STAT pin) not to exceed P_D----- 20mA
- Source current (STAT pin) not to exceed P_D ----- 10mA
- Output current (CC pin) not to exceed P_D ----- 40mA
- Maximum Junction Temperature, T_J ----- 150°C
- Storage temperature range, T_{stg} ----- -65°C to 150°C
- Lead temperature (soldering, 10s) ----- 300°C
- Package Thermal Resistance, θ_{JA}- MSOP8 ----- 80°C/W

Recommended Operating Conditions

	Min.	Max.	Unit
Supply voltage, V _{CC}	4.5	7	V
Operating free-air temperature range, T _A	-20	70	°C

Electrical Characteristics over Recommended Operating Free-Air Temperature Range

Symbol	Parameter	Conditions	EUP8051A			Unit
			Min.	Typ.	Max.	
I _(VCC)	V _{CC} current	V _{CC} =5V > V _{CC(min)} , Excluding external loads		0.5	1	mA
I _(VCCS)	V _{CC} Sleep current	V _(BAT) ≥ V _(min) , V _(BAT) -V _{CC} ≥ 0.8V			6	µA
I _{IB(BAT)}	Input bias current on BAT pin	V _(BAT) =V _(REG)			1	µA
I _{IB(SNS)}	Input bias current on SNS pin	V _(SNS) =5V			1	µA
I _{IB(TS)}	Input bias current on TS pin	V _(TS) =5V			1	µA
I _{IB(PI)}	Input bias current on PI pin	V _(PI) =5V			1	µA
Battery Voltage Regulation						
V _{O(REG)}	Output voltage	EUP8051A-4.2	4.158	4.20	4.242	V

Electrical Characteristics Over Recommended Operating Free-Air Temperature Range

Symbol	Parameter	Conditions	EUP8051A			Unit
			Min.	Typ.	Max.	
$V_{(SNS)}$	Current regulation threshold	Voltage at pin SNS, relative to V_{CC}	180	200	220	mV
Charge Termination Detection						
$I_{(TERM)}$	Charge termination current detect threshold	Voltage at pin SNS, relative to V_{CC} $0^{\circ}\text{C} \leq T_A \leq 50^{\circ}\text{C}$	5	15	25	mV
Temperature Comparator						
$V_{(TS1)}$	Lower temperature threshold	TS pin voltage	29	30	31	% V_{CC}
$V_{(TS2)}$	Upper temperature threshold		58	60	62	
Precharge Comparator						
$V_{(min)}$	Precharge threshold	EUP8051A-4.2	3.14	3.2	3.26	V
Precharge Current Regulation						
$I_{(PRECHG)}$	Precharge current regulation	Voltage at pin SNS, relative to V_{CC} $0^{\circ}\text{C} \leq T_A \leq 50^{\circ}\text{C}$		18		mV
		Voltage at pin SNS, relative to V_{CC} $0^{\circ}\text{C} \leq T_A \leq 50^{\circ}\text{C}$, $V_{CC}=5\text{V}$	5		33	mV
V_{RCH} comparator(Battery Recharge Threshold)						
$V_{(RCH)}$	Recharge threshold	EUP8051A-4.2	$V_{O(REG)}^{-}$ 102mV	$V_{O(REG)}^{-}$ 100mV	$V_{O(REG)}^{-}$ 98mV	V
STAT Pin						
$V_{OL(STAT)}$	Output(low)voltage	$I_{OL}=10\text{mA}$			0.7	V
$V_{OH(STAT)}$	Output(high)voltage	$I_{OH}=5\text{mA}$	$V_{CC}-0.8$			
CC Pin						
$V_{OL(CC)}$	Output low voltage	$I_{O(CC)}=5\text{mA}(\text{sink})$			2	V
$I_{O(CC)}$	Sink current	Not to exceed power rating specification(P_D)	5		40	mA

Typical Operating Characteristics

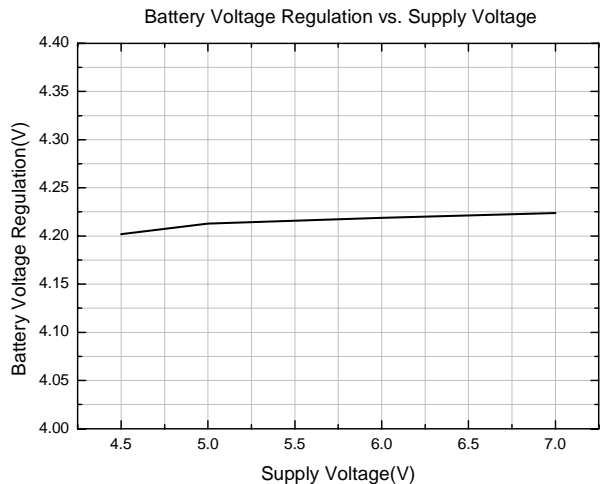
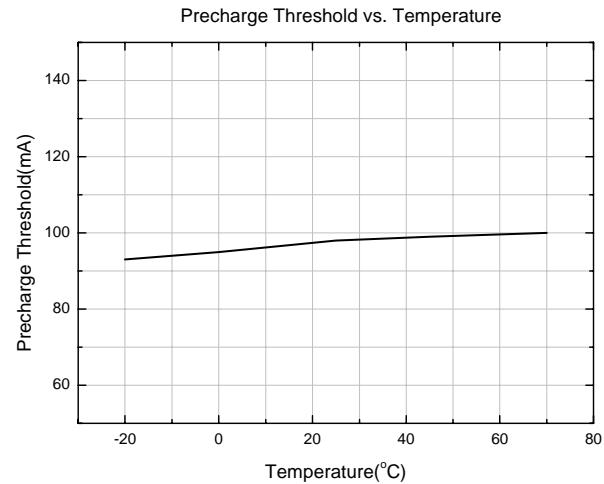
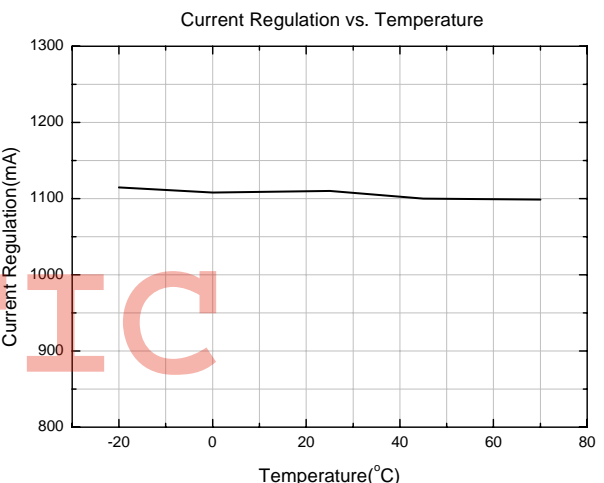
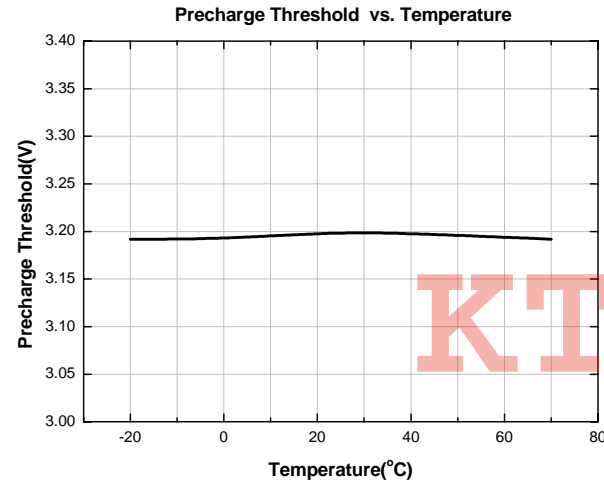
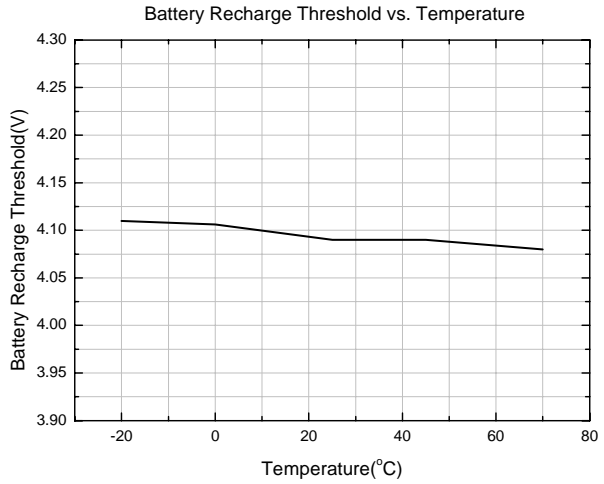
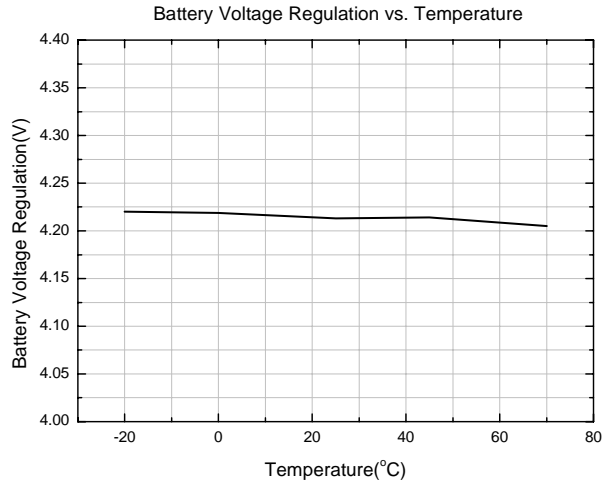

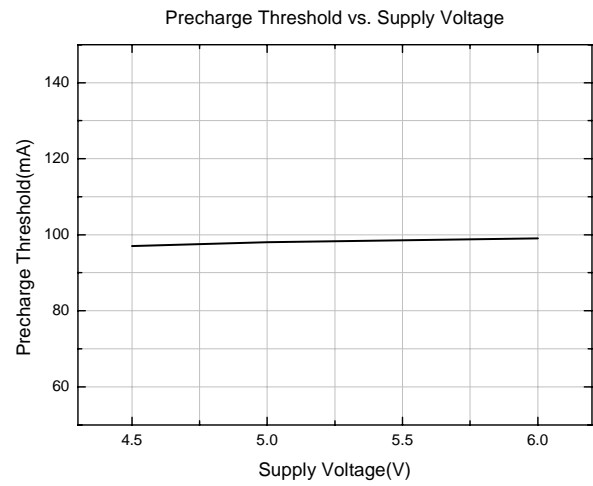
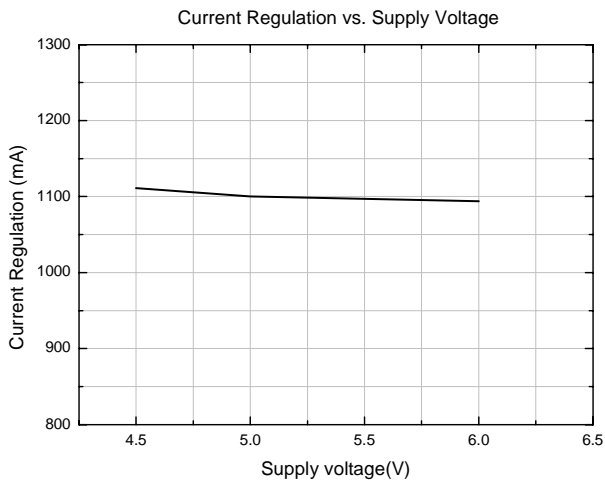

KTTIC

Application Information

Functional Description

The EUP8051A is an advanced 1A linear charge controller for single Li-Ion or Li-Pol applications. Refer to Blocking Diagram (Figure3) and Operation Flow Chart (Figure4) in this section.

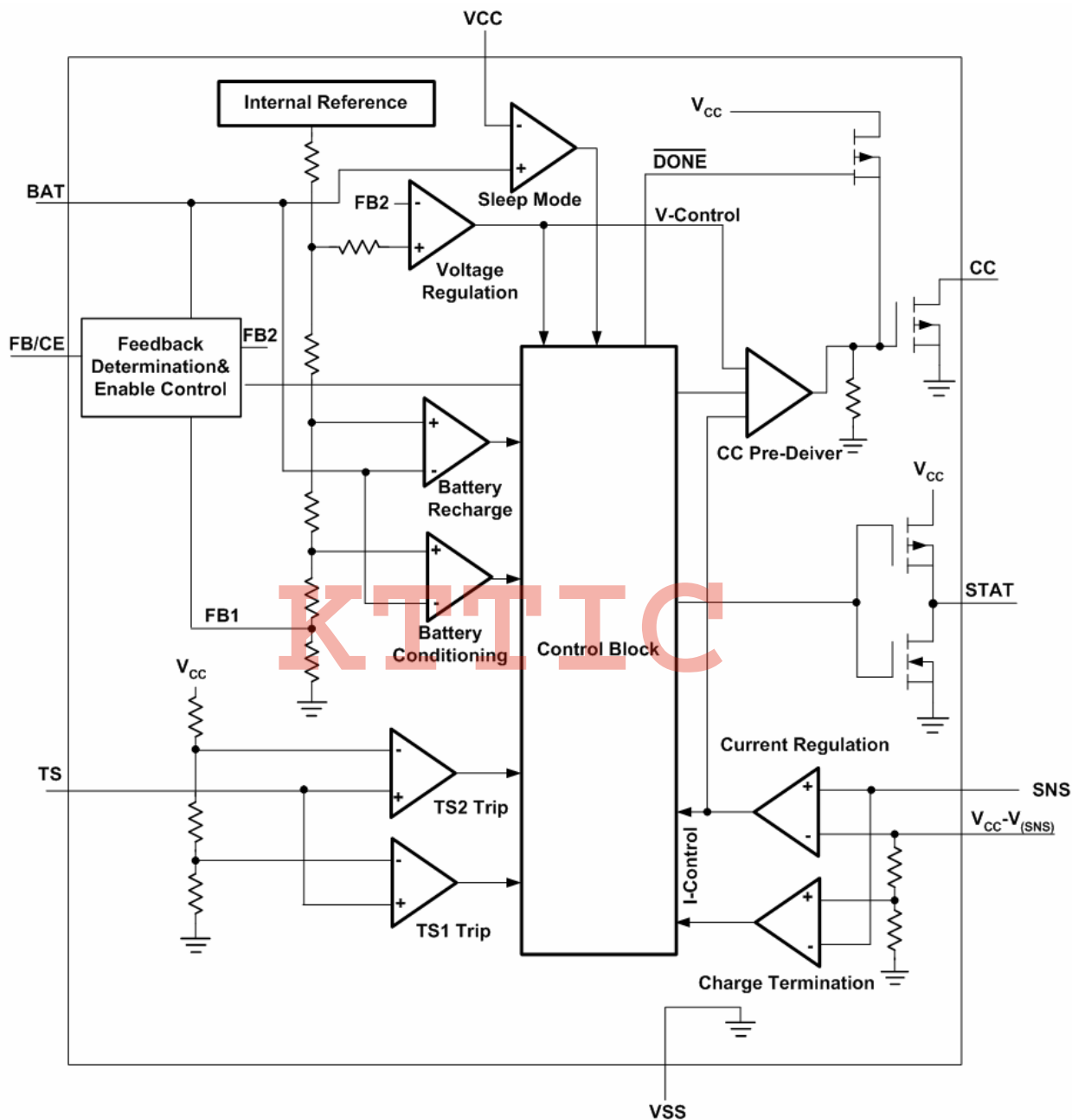

Figure3. Block Diagram

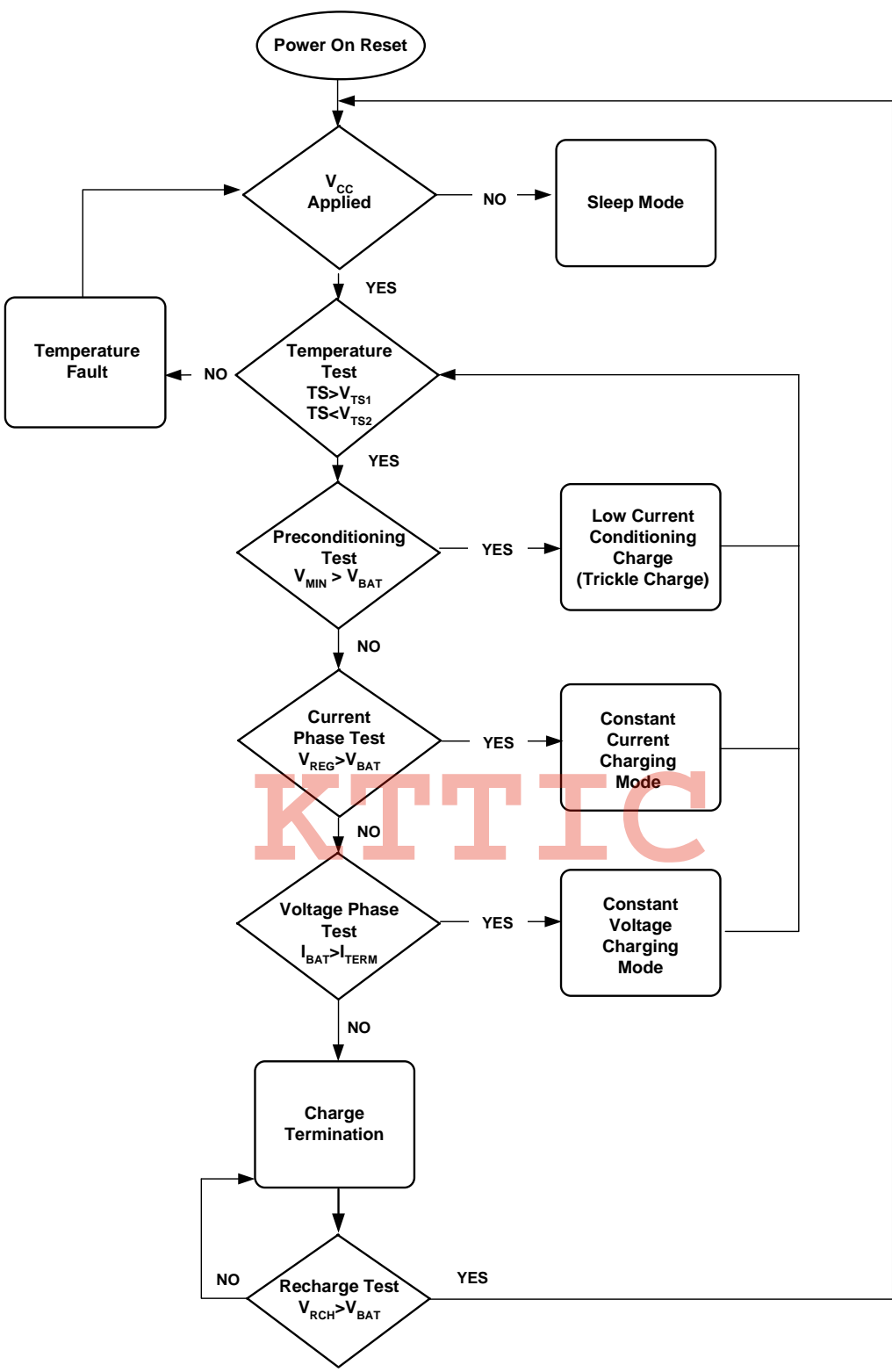

Figure4. Operation Flow Chart

Qualification and Precharge

When power is applied, the EUP8051A starts a charge-cycle if a battery is already present or when a battery is inserted. Charge qualification is based on battery temperature and voltage.

The EUP8051A suspends charge if the battery temperature is outside the $V_{(TS1)}$ to $V_{(TS2)}$ range and suspends charge until the battery temperature is within the allowed range. The EUP8051A also checks the battery voltage. If the battery voltage is below the precharge threshold $V_{(min)}$, the EUP8051A uses precharge to condition the battery. The conditioning charge rate $I_{(PRECHG)}$ is set at approximately 10% of the regulation current. The conditioning current also minimizes heat dissipation in the external pass-element during the initial stage of charge. See Figure5 for a typical charge-profile.

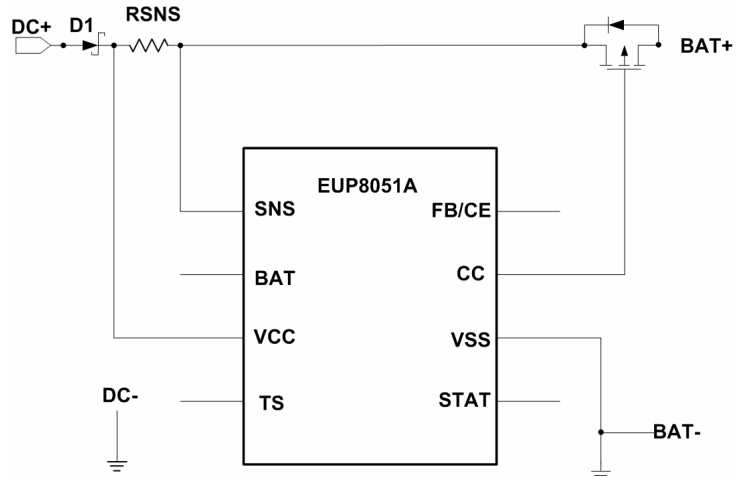

Figure6. Current Sensing Circuit

Voltage Regulation Phase

The voltage regulation feedback is through the BAT pin. This input is tied directly to the positive side of the battery pack. The EUP8051A monitors the battery-pack voltage between the BAT and VSS pins. The EUP8051A is offered in two fixed-voltage versions:4.2V.

FB/CE Pin Function

This pin has two functions, one is to enable/disable the charge function, and the other is to finely adjust battery regulation voltage. Connect this pin to VDD to enable EUP8051A, and connect to ground to disable it (Figure7). If this pin is connected to a voltage divider as shown in Figure8, it can be a 2.15V reference voltage to adjust the output regulation voltage as desired.

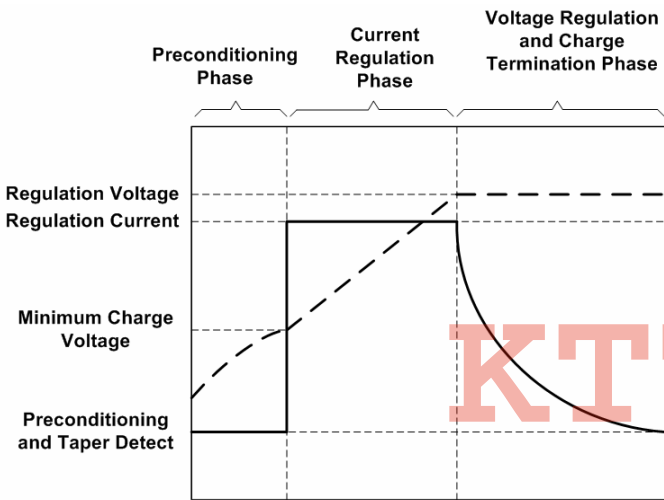

Figure5. Typical Charge Profile

Current Regulation Phase

The EUP8051A regulates current while the battery-pack voltage is less than the regulation voltage, $V_{O(REG)}$. The EUP8051A monitors charge current at the SNS input by the voltage drop across a sense-resistor, R_{SNS} , in series with the battery pack. In current sensing configuration (Figure6), R_{SNS} is between the VCC and SNS pins, charge-current feedback, applied through pin SNS, maintains a voltage of $V_{(SNS)}$ across the current sense resistor. The following formula calculates the value of the sense resistor:

$$R_{SNS} = \frac{V_{(SNS)}}{I_{O(REG)}} \quad \text{----- (1)}$$

Where $I_{O(REG)}$ is the desired charging current.

Example: For 0.55A, R_{SNS} : 0.22V/0.55A: 0.4Ω

For 1.0A, R_{SNS} : 0.22V/1.0A: 0.22Ω

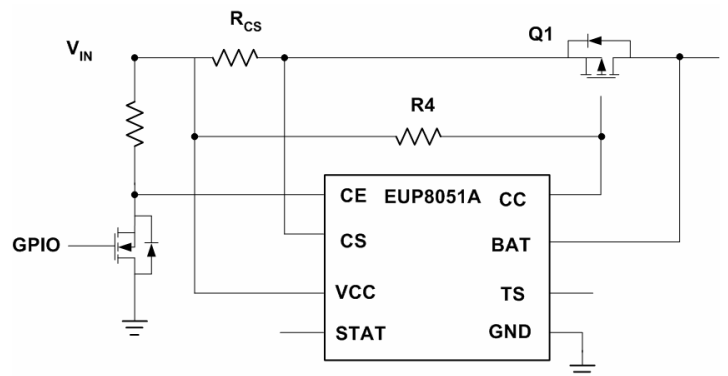

Figure7. For CE pin Function

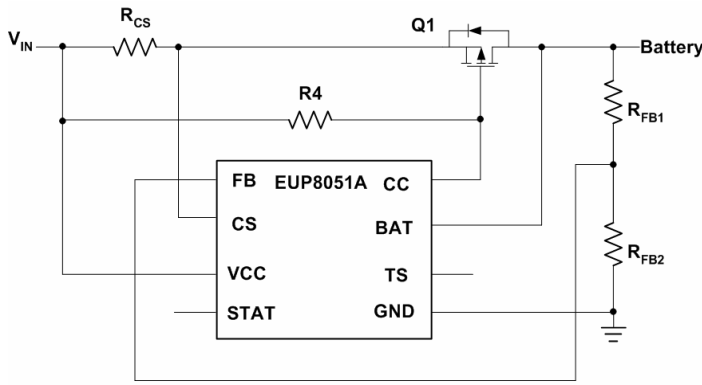

Figure8. For FB pin Function

$$V_{O(REG)} = 2.15 \times \left(1 + \frac{R_{FB1}}{R_{FB2}}\right)V$$

Charge Termination and Recharge

The EUP8051A monitors the charging current during the voltage-regulation phase. The EUP8051A declares a done condition and terminates charge when the current drops to the charge termination threshold, $I_{(TERM)}$. A new charge cycle begins when the battery voltage falls below the $V_{(RCH)}$ threshold.

Battery Temperature Monitoring

The EUP8051A continuously monitors temperature by measuring the voltage between the TS and VSS pins. A negative-or a positive-temperature coefficient thermistor (NTC, PTC) and an external voltage divider typically develop this voltage (See Figure9). The EUP8051A compares this voltage against its internal $V_{(TS1)}$ and $V_{(TS2)}$ thresholds to determine if charging is allowed. (See Figure10). The temperature sensing circuit is immune to any fluctuation in VCC, since both the external voltage divider and the internal thresholds ($V_{(TS1)}$ and $V_{(TS2)}$) are referenced to VCC.

The resistor values of $R_{(T1)}$ and $R_{(T2)}$ are calculated by the following equations:

For NTC Thermistors

$$R_{T1} = \frac{5 \times R_{TH} \times R_{TC}}{3 \times (R_{TC} - R_{TH})} \quad \text{----- (3)}$$

$$R_{T2} = \frac{5 \times R_{TH} \times R_{TC}}{[(2 \times (R_{TC})) - (7 \times R_{TH})]} \quad \text{----- (4)}$$

For PTC Thermistors

$$R_{T1} = \frac{5 \times R_{TH} \times R_{TC}}{3 \times (R_{TH} - R_{TC})} \quad \text{----- (5)}$$

$$R_{T2} = \frac{5 \times R_{TH} \times R_{TC}}{[(2 \times (R_{TH})) - (7 \times R_{TC})]} \quad \text{----- (6)}$$

Where $R_{(TC)}$ is the cold temperature resistance and $R_{(TH)}$ is the hot temperature resistance of thermistor, as specified by the thermistor manufacturer.

R_{T1} or R_{T2} can be omitted if only one temperature (hot or cold) setting is required. Applying a voltage between the $V_{(TS1)}$ and $V_{(TS2)}$ thresholds to pin TS disables the temperature-sensing feature.

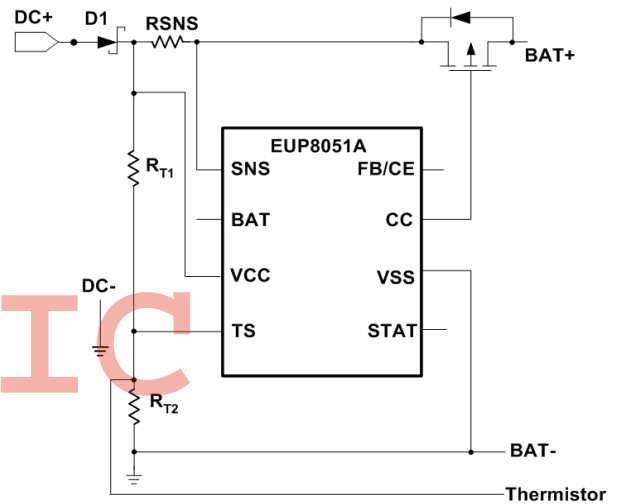

Figure9. Temperature Sensing Circuits

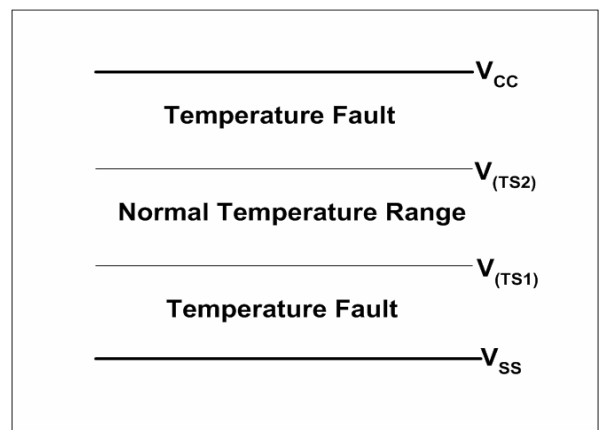

Figure10. EUP8051A TS Input Thresholds

Charge Inhibit Function

The TS pin can be used as charge-inhibit input. The user can inhibit charge by connecting the TS pin to VCC or VSS (or any level outside the $V_{(TS1)}$ to $V_{(TS2)}$ thresholds). Applying a voltage between the $V_{(TS1)}$ and $V_{(TS2)}$ thresholds to pin TS returns the charger to normal operation.

Charge Status Indication

The EUP8051A reports the status of the charger on the 3-state STAT pin. The following table summarized the operation of the STAT pin.

Condition	STAT pin
Battery conditioning and charging	High
Charge complete(done)	Low
Temperature fault or sleep mode	Hi-Z

The STAT pin can be used to drive a single LED (Figure1), dual-chip LEDs (Figure2) or for interface to a host or system processor (Figure11). When interfacing the EUP8051A to a processor, the user can use an output port, to recognize the high-Z state of the STAT pin. In this configuration, the user needs to read the input pin, toggle the output port and read the STAT pin again. In a high-Z condition, the input port always matches the signal level on the output port.

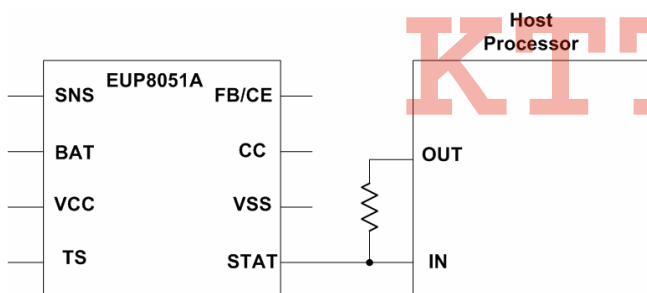

Figure11. Interfacing the EUP8051A to a Host Processor

Low-Power Sleep Mode

When the input supply is disconnected, the charger automatically enters power-saving sleep mode. Only consuming an ultra-low 1 μ A in sleep mode, the EUP8051A minimizes battery drain when it is not charging.

Selecting Input Capacitor

In most applications, all that is needed is high-frequency decoupling capacitor. A 0.1 μ F ceramic, placed in proximity to VCC and VSS pins, works well. The EUP8051A works with both regulated and unregulated external dc supplies. If a non-regulated supply is chosen, the supply unit should have enough capacitance to hold up the supply voltage to the minimum required input voltage at maximum load. If not, more capacitance must be added to the input of the charger.

Selecting Output Capacitor

The EUP8051A does not require any output capacitor for loop stability.

In order to maintain good AC stability in the Constant Voltage mode, a minimum capacitance of 10 μ F is recommended to bypass the V_{BAT} pin to V_{SS} . This capacitance provides compensation when there is no battery load. In addition, the battery and interconnections appear inductive at high frequencies. These elements are in the control feedback loop during Constant Voltage mode. Therefore, the bypass capacitance may be necessary to compensate for the inductive nature of the battery pack.

Virtually any good quality output filter capacitor can be used, independent of the capacitor's minimum ESR (Effective Series Resistance) value. The actual value of the capacitor and its associated ESR depends on the forward transconductance (gm) and capacitance of the external pass transistor. A 10 μ F tantalum or aluminum electrolytic capacitor at the output is usually sufficient to ensure stability for up to a 1A output current.

Selecting An External Pass-Device (PMOS or PNP)

The EUP8051A is designed to work with both P-channel MOSFET or PNP transistor. The device should be chosen to handle the required power dissipation, given the circuit parameters, PCB layout and heat sink configuration. The following examples illustrate the design process for PMOS device:

P-Channel MOSFET

Selection steps for a P-channel MOSFET: We will use the following conditions: $V_I=5V$ (with 10% supply tolerance); $I_{(REG)}=1A$, 4.2-V single-cell Li-Ion. V_I is the input voltage to the charger and $I_{(REG)}$ is the desired charge current. (See Figure2)

1. Determine the maximum power dissipation, P_D , in the transistor.
The worst case power dissipation happens when the cell voltage, $V_{(constant)}$, is at its lowest (typically 3.1V at the beginning of current regulation phase) and V_I is at its maximum. Where V_D is the forward voltage drop across the reverse-blocking diode (if one is used), and V_{CS} is the voltage drop across the current sense resistor.

$$P_D = (V_{I(MAX)} - V_D - V_{CS} - V_{BAT}) \times I_{REG} \text{ ----- (7)}$$

$$P_D = (5.5 - 0.4 - 0.2 - 3.1) \times 1A$$

$$P_D = 1.8W$$

2. Determine the package size needed in order to keep the junction temperature below the manufacturer's recommended value, T_{JMAX} . Calculate the total theta, $\theta(^{\circ}C/W)$, needed.

$$\theta_{JA} = \frac{(T_{max(J)} - T_{A(max)})}{P_D} \text{ ----- (8)}$$

$$\theta_{JA} = \frac{(150 - 40)}{1.8} \quad \theta_{JA} = 61^{\circ}C/W$$

It is recommended to choose a package with a lower θ_{JA} than the number calculated above.

3. Select a drain-source voltage, $V_{(DS)}$, rating greater than the maximum input voltage. A 12V device will be adequate in this example.
4. Select a device that has at least 50% higher drain current (I_D) rating than the desired charge current $I_{(REG)}$.
5. Verify that the available drive is large enough to supply the desired charge current.

$$V_{(GS)} = (V_D + V_{(CS)} + V_{OL(CC)}) - V_{I(min)} \text{ ----- (9)}$$

$$V_{(GS)} = (0.4 + 0.2 + 1) - 4.5$$

$$V_{(GS)} = -2.9$$

Where $V_{(GS)}$ is the gate-to-source voltage, V_D is the forward voltage drop across the reverse-blocking diode (if one is used), and V_{CS} is the voltage drop across the current sense resistor, and $V_{OL(CC)}$ is the CC pin output low voltage specification for the EUP8051A.

Select a MOSFET with gate threshold voltage, $V_{(GSth)}$, rating less than the calculated $V_{(GS)}$.

Reverse Blocking Protection

The optional reverse-blocking protection diode, depicted in Figure1&2 provides protection from a faulted or shorted input, or from a reversed-polarity input source. Without the protection diode, a faulted or shorted input would discharge the battery pack through the body diode of the external pass transistor.

If a reverse-protection diode is incorporated in the design, it should be chosen to handle the fast charge current continuously at the maximum ambient temperature. In addition, the reverse-leakage current of the diode should be kept as small as possible.



Packaging Information

8-Pin MSOP

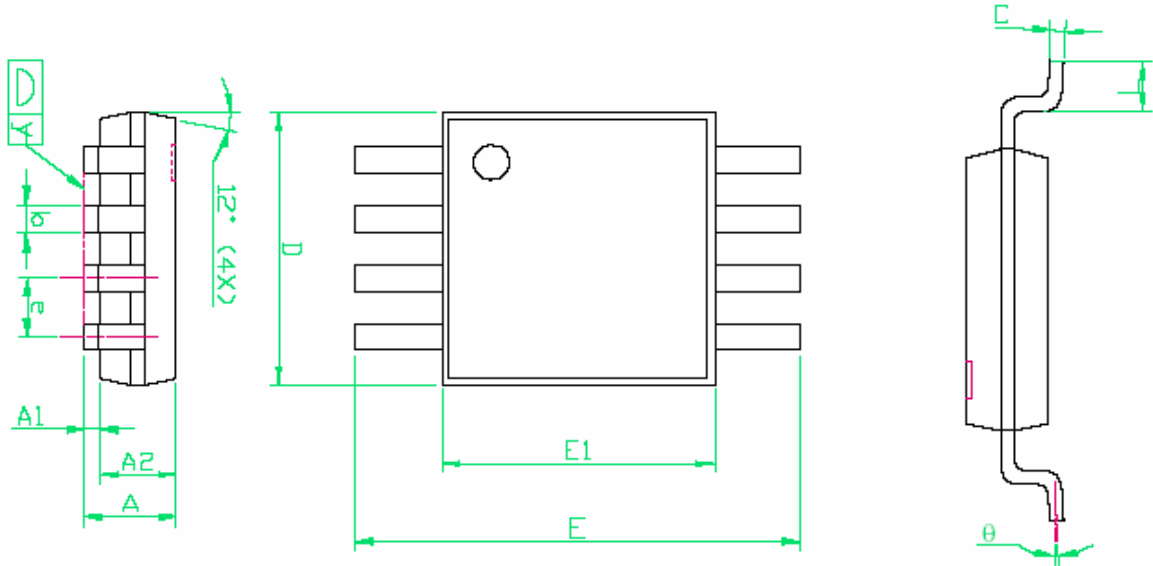

NOTE

1. Package body sizes exclude mold flash and gate burrs
2. Dimension L is measured in gage plane
3. Tolerance 0.10mm unless otherwise specified
4. Controlling dimension is millimeter. Converted inch dimensions are not necessarily exact.

SYMBOLS	DIMENSIONS IN MILLIMETERS			DIMENSIONS IN INCHES		
	MIN.	NOM.	MAX.	MIN.	NOM.	MAX.
A	0.81	0.95	1.10	0.032	0.0375	0.043
A1	0.05	0.09	0.15	0.002	0.004	0.006
A2	0.76	0.86	0.97	0.030	0.034	0.038
b	0.28	0.30	0.38	0.011	0.012	0.015
C	0.13	0.15	0.23	0.005	0.006	0.009
D	2.90	3.00	3.10	0.114	0.118	0.122
E	4.70	4.90	5.10	0.185	0.193	0.201
E1	2.90	3.00	3.10	0.114	0.118	0.122
e	-----	0.65	-----	-----	0.026	-----
L	0.40	0.53	0.66	0.016	0.021	0.026
y	-----	-----	0.10	-----	-----	0.004
θ	0	-----	6	0	-----	6