



# +3.0V to +5.5V USB Power Control Switch

- Compliant to USB Specifications
- +3.0V to +5.5V Input Voltage Range
- Open Drain Error Flag Output
- 2.7V Undervoltage Lockout
- 500mA Minimum Continuous Load Current
- 1.25A Short Circuit Current Limit
- Thermal Shutdown
- 1ms Soft-Start Power Up
- Active-High Version: **SP2525-1**
- Active-Low Version: **SP2525-2**

*Now Available in Lead Free Packaging*

## DESCRIPTION

The SP2525 device is a single +3.0V to +5.5V USB Supervisory Power Control Switch ideal for self-powered and bus-powered Universal Serial Bus (USB) applications. The SP2525 device has low on-resistance (80mΩ typical) and can supply 500mA minimum. The fault currents are limited to 2.0A typical and the flag output pin is available to indicate fault conditions to the USB controller. The 1ms soft start of the SP2525 device will eliminate any momentary voltage drop on the upstream port that may occur when the switch is enabled in bus-powered applications. The thermal shutdown feature will prevent permanent damage to the SP2525 device when subjected to excessive current loads. The under voltage lockout feature will ensure that the SP2525 device will remain off unless there is a valid input voltage present.

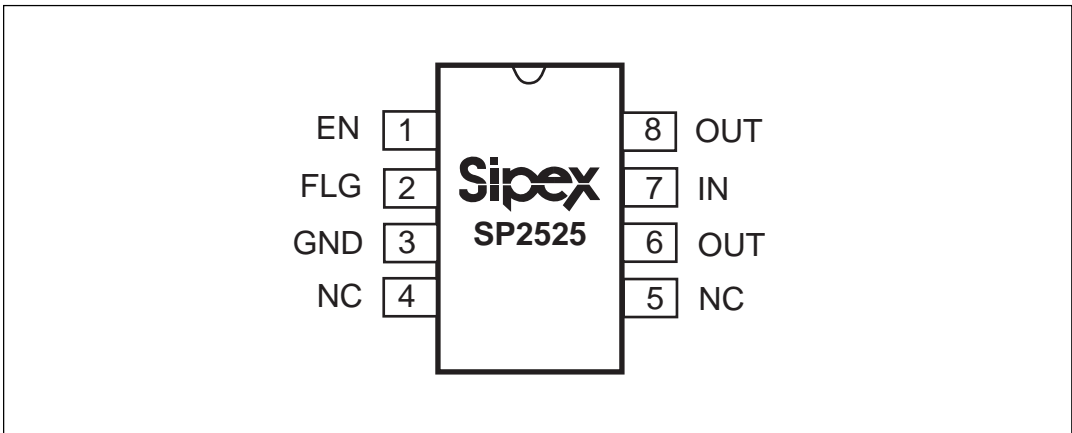

**ABSOLUTE MAXIMUM RATINGS**

These are stress ratings only and functional operation of the device at these ratings or any other above those indicated in the operation sections of the specifications below is not implied. Exposure to absolute maximum rating conditions for extended periods of time may affect reliability.

Supply Voltage.....-0.3V, +6.0V  
 Operating Temperature.....-40°C to +85°C  
 Storage Temperature.....-65°C to +150°C

Power Dissipation Per Package  
 8-pin NSOIC (derate 6.14mW/°C above +70°C).....500mW



**CAUTION:**  
 ESD (ElectroStatic Discharge) sensitive device. Permanent damage may occur on unconnected devices subject to high energy electrostatic fields. Unused devices must be stored in conductive foam or shunts. Personnel should be properly grounded prior to handling this device. The protective foam should be discharged to the destination socket before devices are removed.

**SPECIFICATIONS**

Unless otherwise noted, the following specifications apply for  $V_{IN} = +5.0V$  and  $T_{AMB} = 25^{\circ}C$ .

PARAMETER	MIN.	TYP.	MAX.	UNITS	CONDITIONS
Operating Voltage Range, $V_{IN}$	3.0		5.5	V	
Supply Current, $I_{IN}$		0.05 80	5.0 140	$\mu A$	enable off, no output load enable on, no output load
Enable Input Threshold Voltage	0.8	2.1 1.9	2.4	V	low to high transition high to low transition
Enable Input Current		0.01 0.01	1 1	$\mu A$	$V_{EN}=V_{OH(min)}=2.4V$ $V_{EN}=V_{OL(max)}=0.8V$
Enable Input Capacitance		1		pF	
Switch Resistance		80	140	$m\Omega$	$3.0V \leq V_{IN} \leq 5.5V, I_L \leq 500mA$
Output Turn-On Delay		0.5		ms	$R_L = 10\Omega$
Output Turn-On Rise Time		1		ms	$R_L = 10\Omega$
Output Turn-Off Delay		1	20	$\mu s$	$R_L = 10\Omega$
Output Turn-Off Fall Time		1	20	$\mu s$	$R_L = 10\Omega$
Output Leakage Current		.02	10	$\mu A$	
Current Limit Threshold		2.0	2.8	A	Ramped load applied
Short Circuit Current Limit	0.5	0.75	1.25	A	$V_{OUT} = 0V$
Over-Temperature Shutdown Threshold		135 125		$^{\circ}C$	increasing temperature decreasing temperature
Error Flag Output Resistance		10 15	25 40	$\Omega$	$V_{IN}=5V, I_L=10mA$ $V_{IN}=3.3V, I_L=10mA$
Error Flag Off Current		0.01	1	$\mu A$	$V_{FLAG}=5V$
UVLO Threshold	2.5	2.7 2.6	3.0	V	$V_{IN}$ increasing, $T_{MIN}$ to $T_{MAX}$ $V_{IN}$ decreasing $T_{MIN}$ to $T_{MAX}$

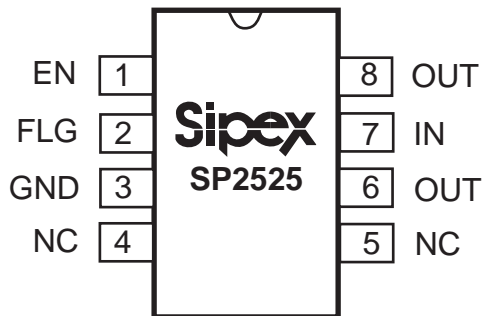

### PIN ASSIGNMENTS

Pin Number	Pin Symbol	Description
1	EN	Enable Input Active High for the SP2525-1 and Active Low for the SP2525-2.
2	FLG	Fault Flag Output —Active-low, open-drain output. Indicates over-current, UVLO and Thermal Shutdown.
3	GND	Ground Reference —Supply return.
4	NC	No Connection.
5	NC	No Connection.
6, 8	OUT	Switch Output Connect Out Pins Together
7	IN	Supply Voltage (Input)

The SP2525 device is a single +3.0V to +5.5V USB Supervisory Power Control Switch ideal for self-powered and bus-powered Universal Serial Bus (USB) applications. USB provides a +5.0V bus and ground return line in addition to a twisted pair line for data.

Features of the SP2525 device include current limiting, a +2.7V undervoltage lockout, over-temperature shutdown, error flag output, soft start power up, a switch-on resistance of 140m $\Omega$  over the entire supply range, and a supply current of 80 $\mu$ A. The SP2525-1 device has active-high inputs. The SP2525-2 device has active-low inputs.

## THEORY OF OPERATION

There are operational conditions that will enable or disable one or more of the output transistors, depending on the type of hazard. Certain conditions will activate the open-drain error flag transistors forcing the flag output to ground. The SP2525 device is a single integrated high-side power switch optimized for self-powered and bus-powered Universal Serial Bus (USB) applications. The SP2525 device provides the following functions:

- 1) Solid State Switch : MOSFET M1 connects the IN pin to the OUT pins when enabled by a logic signal at the EN pin.
- 2) Fault Flag Conditions : The FLG pin is an N-channel, open-drain MOSFET output capable of sinking a 10mA load to typically 100mV above ground.
- 3) Undervoltage Lockout : The lockout mechanism monitors the input voltage and will enable the MOSFET switch only when the input signal is  $\geq 2.7V$ .
- 4) Current Limiting Threshold : A current limiting threshold is set internally to prevent any damage to the device and external load.

5) Thermal Shutdown : This mechanism protects the device switch and signals a fault condition if the die temperature exceeds 135 $^{\circ}C$ . This function has 10 $^{\circ}C$  of hysteresis that prevents the MOSFET switches from turning on until the die temperature drops to 125 $^{\circ}C$ .

## Input and Output

The independent solid state switch connects the IN pin to the OUT pin when enabled by a logic signal at EN. The IN pin is the power supply connection to the internal circuitry and the drain of the output MOSFET. The OUT pin is the source of the MOSFET.

Typically, the current in USB application will flow through the switch from IN to OUT towards the load. If  $V_{OUT}$  is greater than  $V_{IN}$  when a switch is enabled, the current will flow from OUT to the IN pin because the MOSFET channels are bidirectional when switched on.

Under normal operating conditions, the MOSFET switch will present 140m $\Omega$  maximum resistance when closed. The device is designed to allow out pin to be externally forced to a higher voltage than the IN pin when the switch is off.

## Fault Flag Conditions

The fault flag is an N-channel, open drain MOSFET output. The active low fault flag is asserted when one of the following conditions exist:

1. Undervoltage
2. Soft Start
3. Overcurrent
4. Overtemperature

## Undervoltage Lockout

This voltage lockout mechanism prevents the output MOSFET switches from turning on until  $V_{IN}$  is  $\geq 2.7V$ .

After the switch turns on, if the voltage at  $V_{IN}$  drops below +2.5V, the lockout circuitry shuts off the output MOSFET switch and signals the FLG fault flag. In the undervoltage lockout state, the FLG pin will be at a logic low. This detection functions only when the MOSFET switch is enabled.

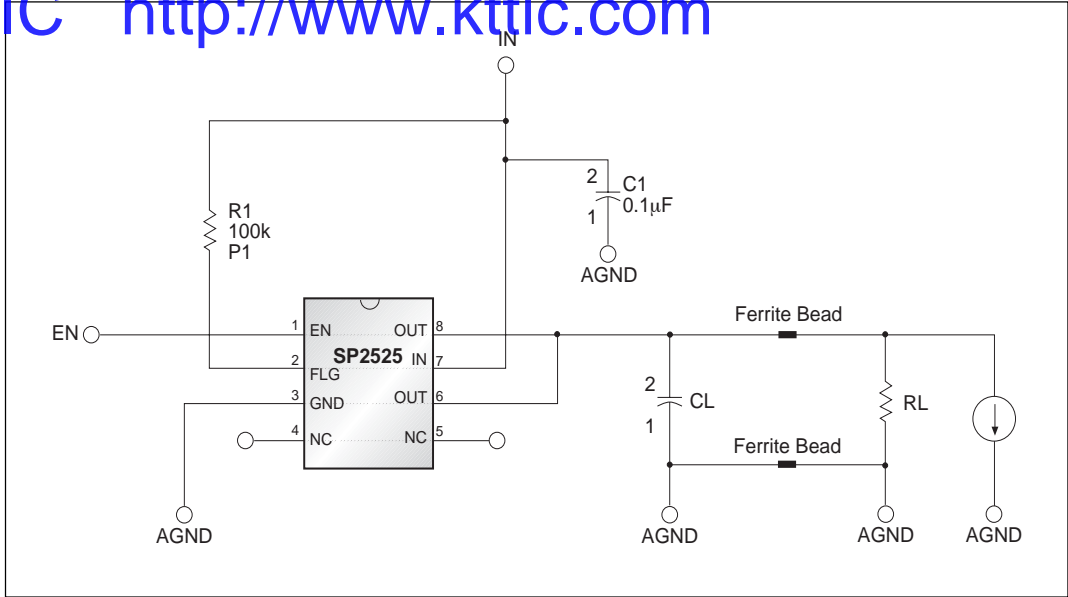

Figure 1. Test Circuit for the SP2525

# KTTIC

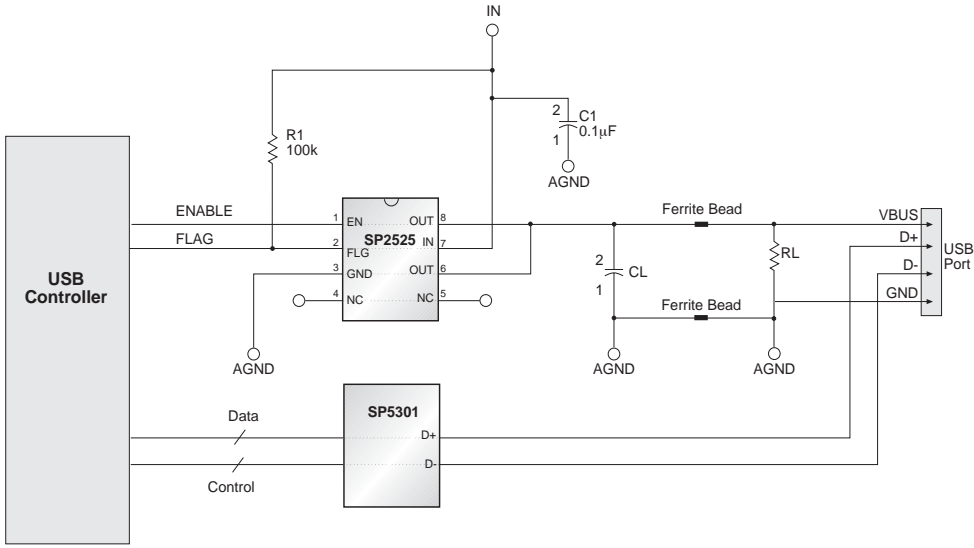

Figure 2. Typical Application Circuit for the SP2525

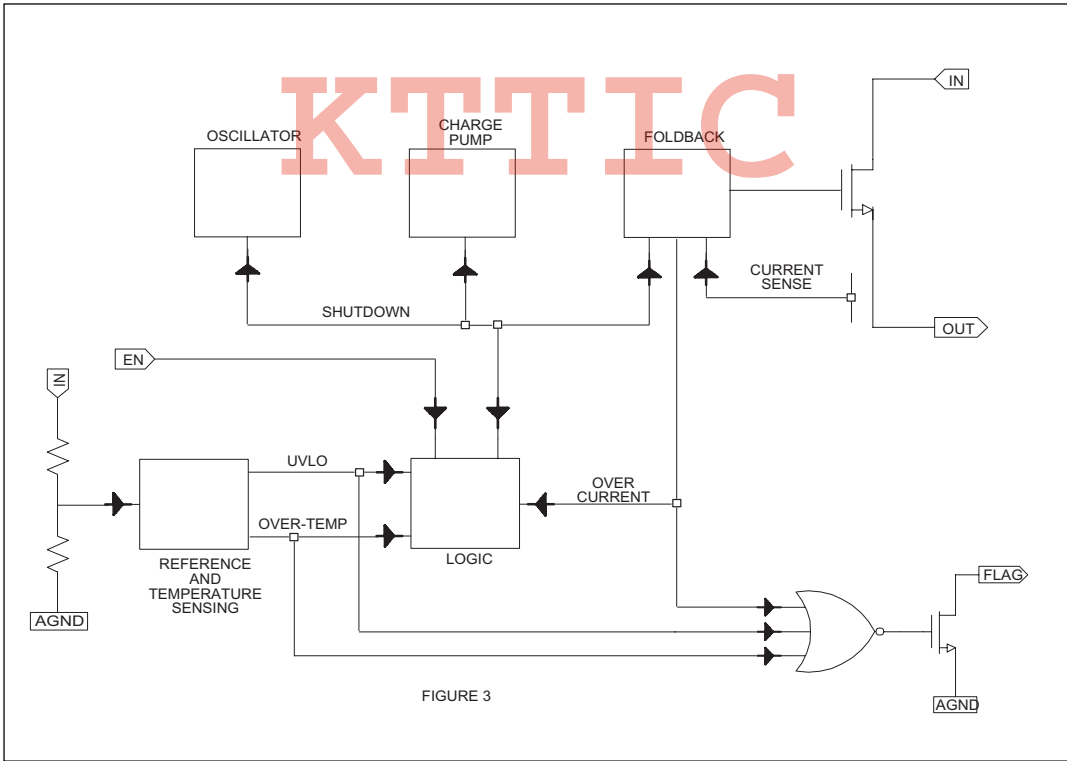

Figure 3. Internal Block Diagram for the SP2525

## Output Current Limiting

The switch control circuit will implement current limiting which prevents damage to the device and the external load while allowing a minimum current of 0.5A.

The SP2525 MOSFET switches will exhibit very low resistance ( $\leq 100\text{m}\Omega$ ) or voltage drop until the current limit is reached. As the load resistance decreases further, the current supplied will decrease until it reaches the foldback current, 500mA minimum. The foldback current is the current that is delivered into a short circuit at the output.

If a MOSFET switch is enabled into a heavy load or short-circuit, the switch will immediately go into a constant-current mode, reducing the output voltage. The fault flag is forced low until the excessive load is removed.

## Thermal Shutdown

Thermal shutdown is asserted if the die temperature exceeds  $135^{\circ}\text{C}$  and will not release until the die temperature drops below  $125^{\circ}\text{C}$ . Thermal shutdown will disable the output MOSFET switch and force fault flag low.

The delay between flag assertion and thermal shutdown can vary with ambient temperature, board layout, and load impedance, but is typically several hundred milliseconds. The USB controller, recognizing a fault, can disable the device within this time, otherwise the device will thermal cycle. This does not cause damage to the SP2525.

## TYPICAL APPLICATIONS

### Bypass Capacitors

Recommended is a  $0.1\mu\text{F}$  to  $1.0\mu\text{F}$  bypass capacitor from the IN pin to the GND pin to control power supply transients. Without a bypass capacitor, an output short may cause sufficient ringing to damage the internal circuitry.

Input or output transients must not exceed the absolute maximum supply voltage even for a short duration without risk of damage to the device.  $V_{\text{IN(MAX)}} = +6.0\text{V}$ .

## Soft Start Condition

The soft start feature of the SP2525 device is implemented by holding the output turn on rise time to 1ms. When off, the device has high impedance MOSFET channels that slowly become low impedance as the device powers on. This prevents an inrush current from causing voltage drops that result from charging a capacitive load. This satisfies the USB voltage droop requirements for bus-powered applications.

## Enable Input

The EN control pin must be driven to a logic high or logic low for a clearly defined signal input. Floating this control line may cause unpredictable operation.

## Transient Overcurrent Filter

When the SP2525 device is enabled, large values of capacitance at the output of the device will cause inrush current to exceed the short circuit current-limit threshold of the device and assert a flag fault condition. The duration of this time will depend on the size of the output capacitance. During the capacitance charging time, the device enters constant-current mode. As the capacitance is charged, the current decreases below the short circuit current-limit threshold and the fault flags will be de-asserted.

In USB applications, it is required that output bulk capacitance is utilized to support hot-plug occurrences. When the SP2525 device is enabled, the flag may go active for about 1ms due to inrush current exceeding the current-limit. Additionally, during hot-plug events, inrush currents may also cause the fault flag to go active for 1ms. Since these conditions are not valid overcurrent faults, the USB controller must ignore the fault flags during these events. To prevent this, a 1ms RC filter maybe useful as shown in Figure. Alternatively, a 1ms debounce routine may be programmed into the USB logic controller, eliminating the need for the RC filter.

### Soft Start Condition

The soft start feature of the SP2525 is implemented by holding the output turn-on rise time to 1ms. When off, the device has high impedance MOSFET channels that slowly become low impedance as the device powers on. This prevents an inrush current from causing voltage drops that result from charging a capacitive load and can pull the USB voltage bus below specified levels. This satisfies the USB voltage droop requirements for bus-powered applications.

The **SP2525** can provide inrush current limiting for applications with large load capacitances where  $C_{BULK} > 10\mu F$ . Refer to the circuit in *Figure 7* for a configuration that will meet USB transient regulation specifications with large load capacitances.

### Enable Input

The ENA and ENB control pins must be driven to a logic high or logic low for a clearly defined signal input. Floating these control lines may cause unpredictable operation.

### USB Compliance

The SP2525 is ideal for self-powered and bus-powered Universal Serial Bus (USB) applications. A USB port provides a +5.0V bus and ground return line in addition to a twisted pair for data.

The SP2525 will comply with the following USB requirements:

- 1) The fault current is well below the UL 25VA safety requirements;
- 2) The Flag Outputs are available to indicate fault conditions to USB controllers;
- 3) The MOSFET switches' low on-resistance meets USB voltage drop requirements;
- 4) Each MOSFET switch channel can supply 500mA as required by USB downstream devices;

5) Soft start eliminates any momentary voltage drops on the upstream port that may occur when the switches are enabled in bus-powered applications.

Refer to *Table 1* for a USB compliance summary of the SP2525. Additional features include the following:

- 6) An Undervoltage Lockout ensures that the device remains off unless there is a valid input supply voltage present;
- 7) +3.3V and +5.0V logic compatible enable inputs;
- 8) Thermal Shutdown prevents the possibility of catastrophic switch failure from high-current loads;
- 8) The device is available in both active-high and active-low versions.

Refer to *Figures 8 to 23* for typical performance characteristics of the SP2525.



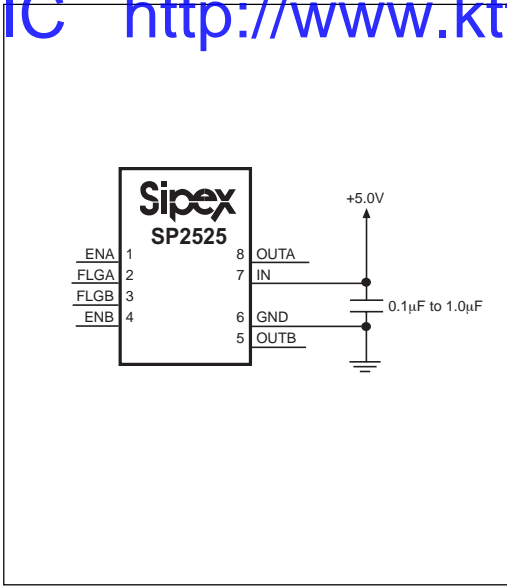

Figure 4. Bypass Capacitor at the Supply Pins

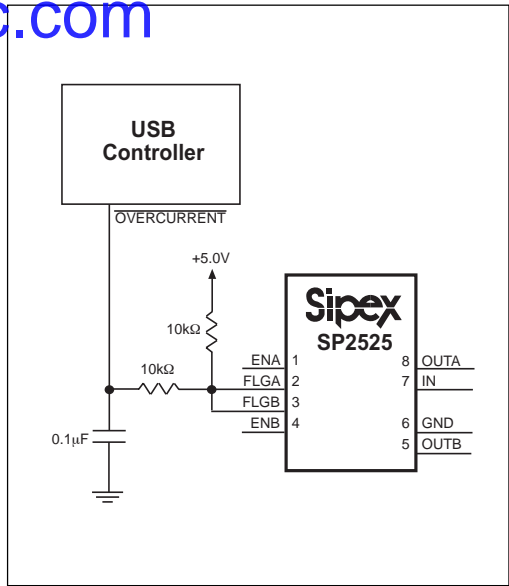

Figure 5. An RC Filter for Overcurrent Faults

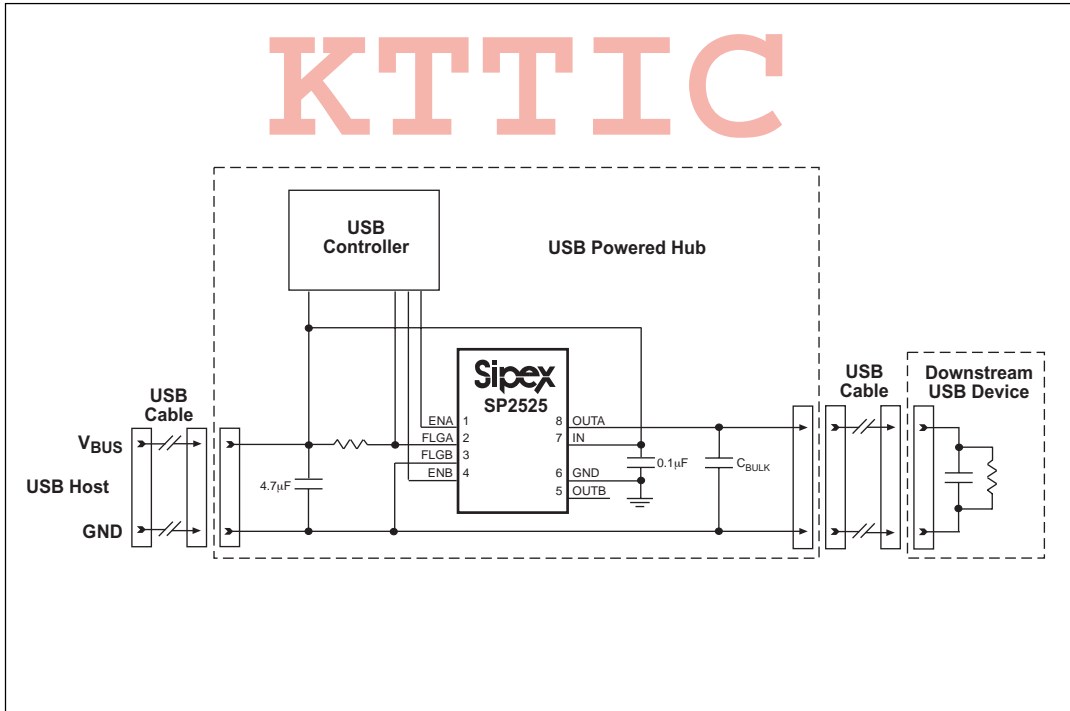

Figure 6. Soft Start Circuit Configuration for a Single Channel USB-powered Application with the SP2526

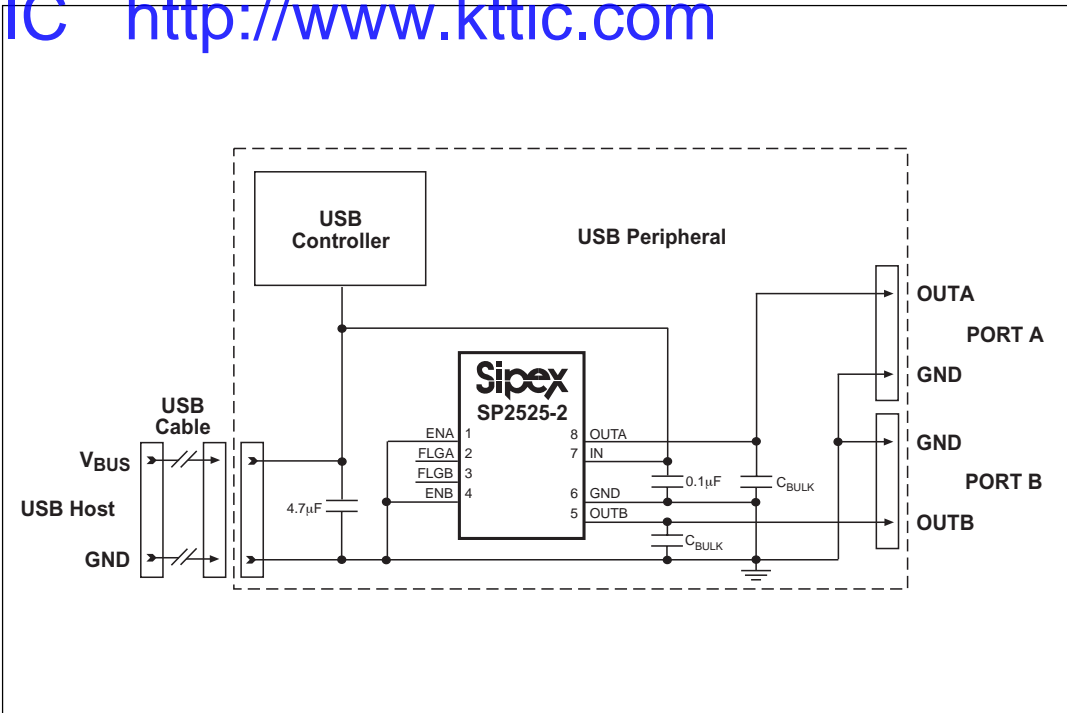

Figure 7. Soft Start Circuit Configuration for SP2526 Applications with Large Load Capacitances

# KTTIC

USB Requirement	SP2525 Compliant Feature
Inrush current limiting required	Soft start turns on in 1ms
Suspend State of <500µA Required	Suspend Current of 1µA maximum
Bus powered hubs must have 350mV maximum drop from cable plug to port	Switch on resistance of 140mΩ maximum (translates to 70mV at 500mA)
Voltage supplied to host or hub port is +4.75V to +5.25V	Operating range of +3.0V to +5.5V
A device that draws bus power must have a stable supply within 100ms of V <sub>BUS</sub> reaching +4.4V	Turns on in 1ms
Over-current reporting capability required	Open drain fault flags

Table 1. USB Protocol Compliance of the SP2525 Device

PERFORMANCE CHARACTERISTICS

$V_{IN} = +5.0V$ , single MOSFET switch section, and  $T_{AMB} = +25^{\circ}C$  unless otherwise noted.

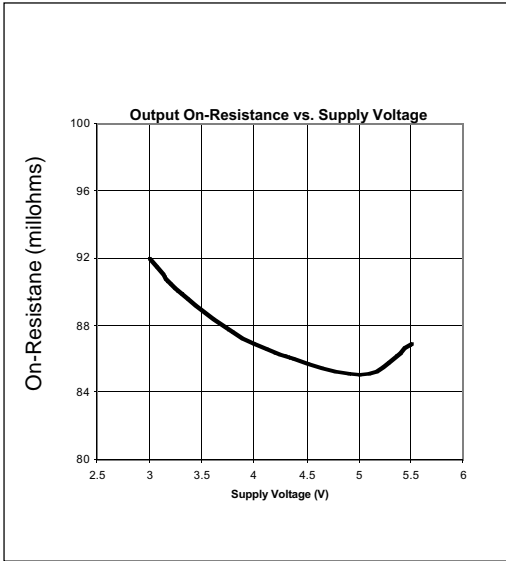

Figure 8. Output On-Resistance vs. Supply Voltage

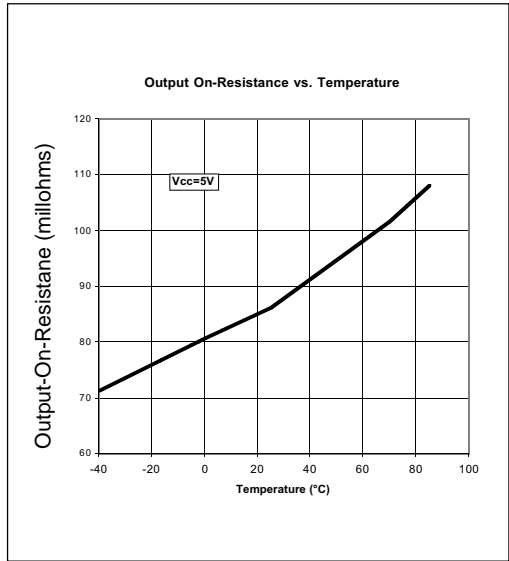

Figure 9. Output On-Resistance vs. Temperature

KTTIC

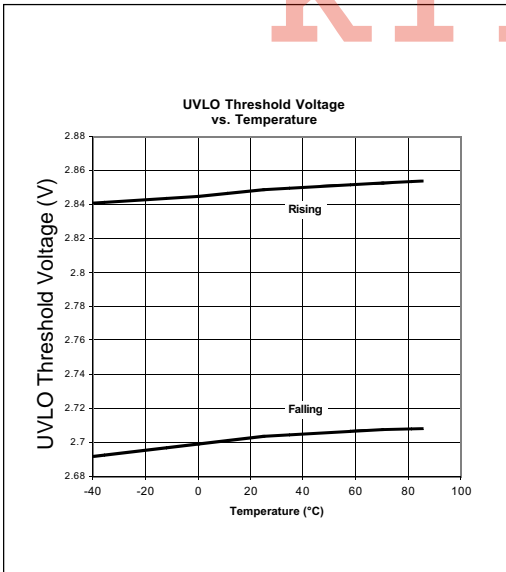

Figure 10. Undervoltage Threshold Voltage vs. Temperature

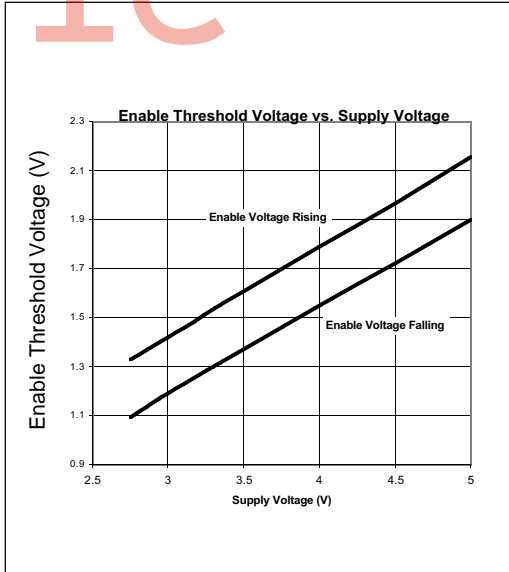

Figure 11. Control Threshold vs. Supply Voltage

PERFORMANCE CHARACTERISTICS

$V_{IN} = +5.0V$ , single MOSFET switch section, and  $T_{AMB} = +25^{\circ}C$  unless otherwise noted.

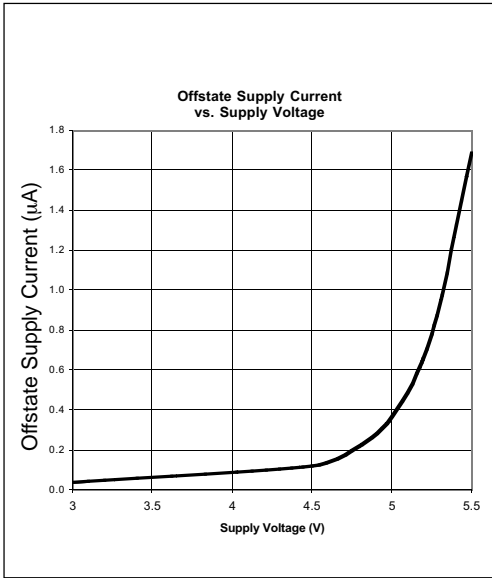

Figure 12. Off-State Supply Current vs. Supply Voltage

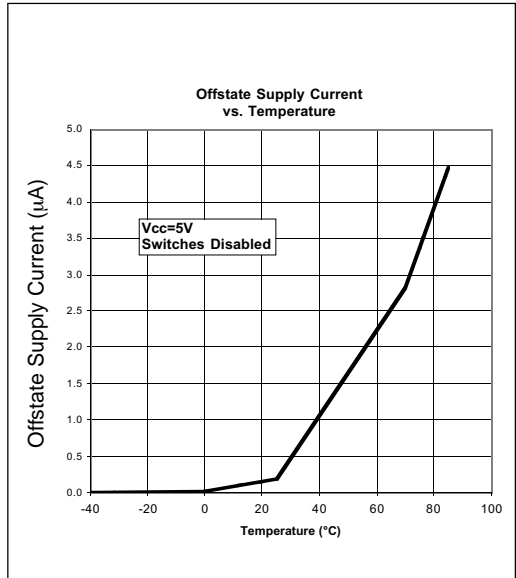

Figure 13. Off-State Supply Current vs. Temperature

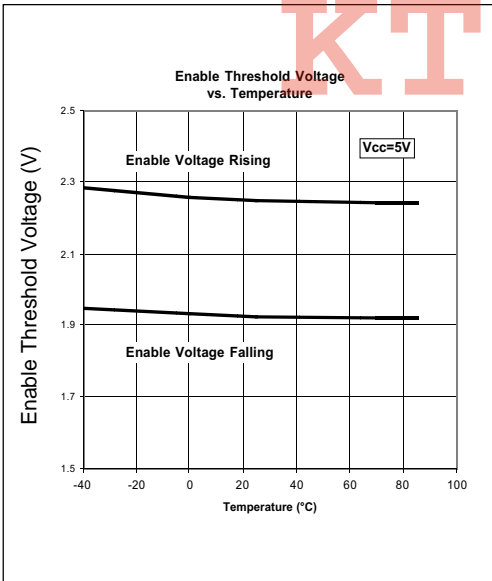

Figure 14. Control Threshold vs. Temperature

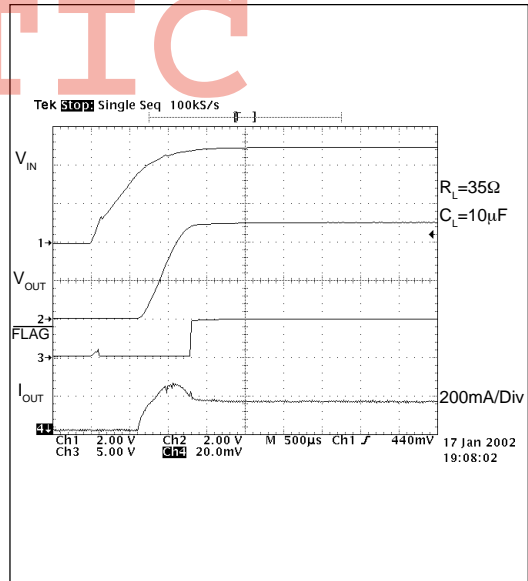

Figure 15. Input Voltage Response

PERFORMANCE CHARACTERISTICS

$V_{IN} = 45.0V$ , single MOSFET switch section, and  $T_{AMB} = +25^{\circ}C$  unless otherwise noted.

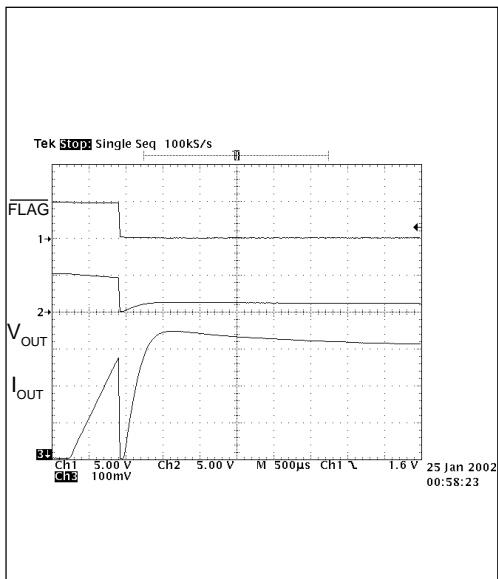

Figure 16. Current-Limit Response with a Ramped Load

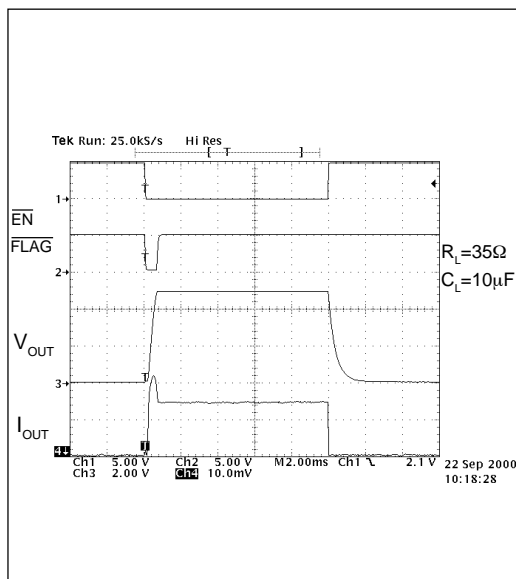

Figure 17. Turn-on/Turn-off Characteristics where  $R_L = 35\Omega$  and  $C_L = 10\mu F$

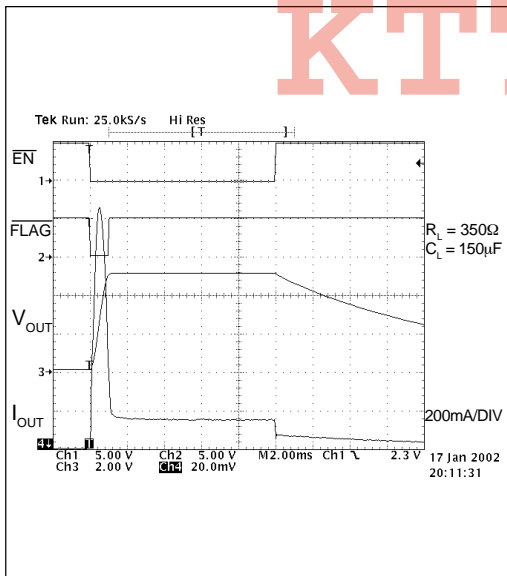

Figure 18. Turn-on/Turn-off Characteristics where  $R_L = 350\Omega$  and  $C_L = 150\mu F$

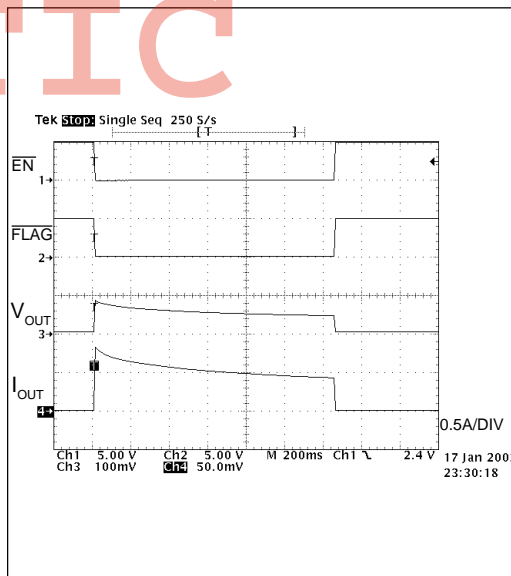

Figure 19. Short Circuit Response (Enable into Short Circuit)

PERFORMANCE CHARACTERISTICS

$V_{IN} = +5.0V$ , single MOSFET switch section, and  $T_{AMB} = +25^{\circ}C$  unless otherwise noted.

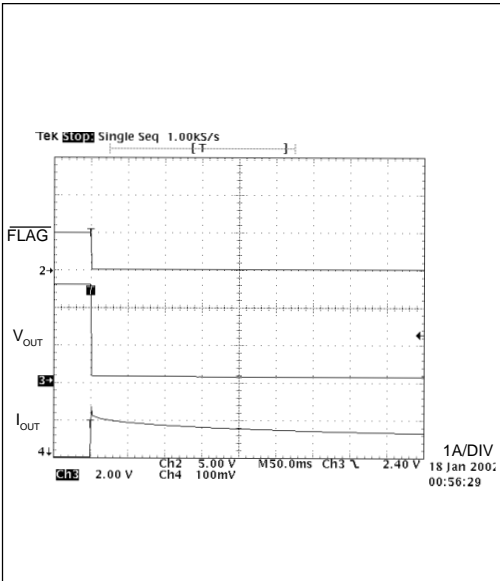

Figure 20. Short Circuit Response (Short Applied to Output)

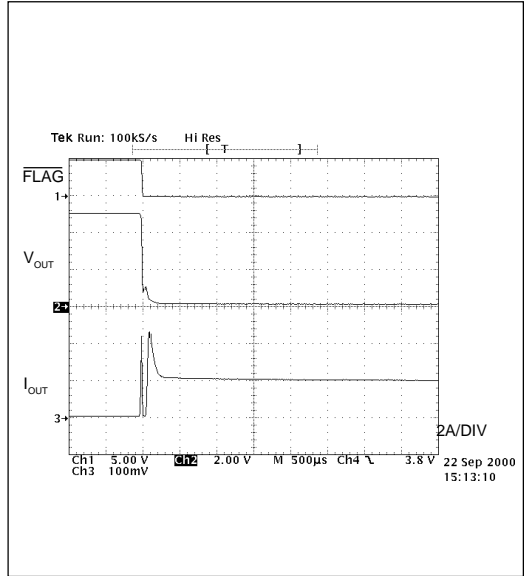

Figure 21. Short Circuit Response (Short Applied to Output)

KTTIC

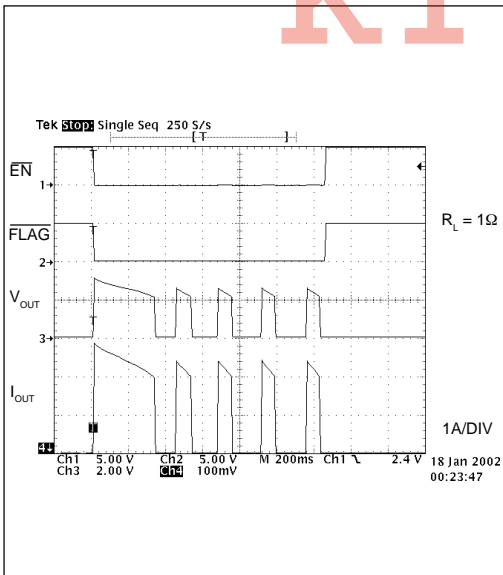

Figure 22. Short Circuit Response (Enable into Short Circuit)

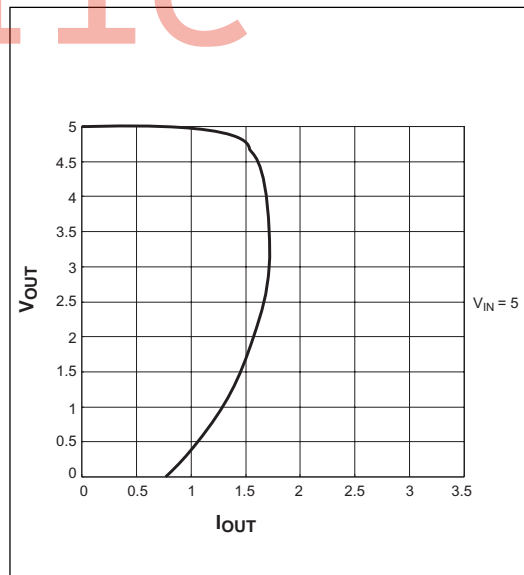
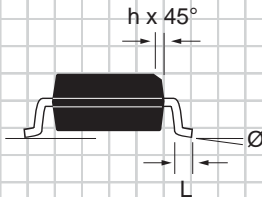
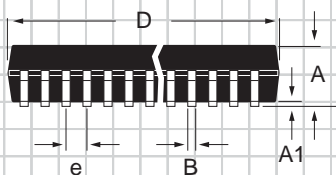
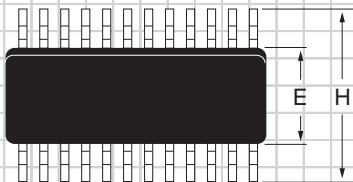

Figure 23. Current Limit Response (Pulsed Load Applied at Output)

**PACKAGE: PLASTIC  
SMALL OUTLINE (SOIC)  
(NARROW)**



DIMENSIONS (Inches) Minimum/Maximum (mm)	8-PIN	14-PIN	16-PIN
A	0.053/0.069 (1.346/1.748)	0.053/0.069 (1.346/1.748)	0.053/0.069 (1.346/1.748)
A1	0.004/0.010 (0.102/0.249)	0.004/0.010 (0.102/0.249)	0.004/0.010 (0.102/0.249)
B	0.014/0.019 (0.35/0.49)	0.013/0.020 (0.330/0.508)	0.013/0.020 (0.330/0.508)
D	0.189/0.197 (4.80/5.00)	0.337/0.344 (8.552/8.748)	0.386/0.394 (9.802/10.000)
E	0.150/0.157 (3.802/3.988)	0.150/0.157 (3.802/3.988)	0.150/0.157 (3.802/3.988)
e	0.050 BSC (1.270 BSC)	0.050 BSC (1.270 BSC)	0.050 BSC (1.270 BSC)
H	0.228/0.244 (5.801/6.198)	0.228/0.244 (5.801/6.198)	0.228/0.244 (5.801/6.198)
h	0.010/0.020 (0.254/0.498)	0.010/0.020 (0.254/0.498)	0.010/0.020 (0.254/0.498)
L	0.016/0.050 (0.406/1.270)	0.016/0.050 (0.406/1.270)	0.016/0.050 (0.406/1.270)
Ø	0°/8° (0°/8°)	0°/8° (0°/8°)	0°/8° (0°/8°)

ORDERING INFORMATION

Model	Temperature Range	Package Types
SP2525-1EN .....	-40°C to +85°C .....	8-pin NSOIC
SP2525-1EN/TR .....	-40°C to +85°C .....	(Tape & Reel) 8-pin NSOIC
SP2525-2EN .....	-40°C to +85°C .....	8-pin NSOIC
SP2525-2EN/TR .....	-40°C to +85°C .....	(Tape & Reel) 8-pin NSOIC

Available in lead free packaging. To order, add "-L" suffix to the part number.  
Example: SP2525-2EN/TR=Tape & Reel. SP2525-2EN-L/TR = lead free.

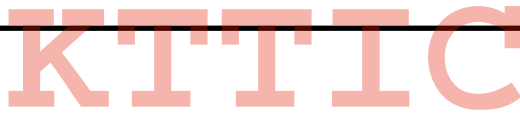

SIGNAL PROCESSING EXCELLENCE

**Sipex Corporation**

**Headquarters and Main Offices:**

22 Linnell Circle  
Billerica, MA 01821  
TEL: (978) 667-8700  
FAX: (978) 670-9001  
e-mail: sales@sipex.com

233 South Hillview Drive  
Milpitas, CA 95035  
TEL: (408) 935-7600  
FAX: (408) 934-7500

Sipex Corporation reserves the right to make changes to any products described herein. Sipex does not assume any liability arising out of the application or use of any product or circuit described herein; neither does it convey any license under its patent rights nor the rights of others.