

M81706AFP

HIGH VOLTAGE HALF BRIDGE DRIVER

DESCRIPTION

M81706AFP is high voltage Power MOSFET and IGBT module driver for half bridge applications.

FEATURES

- FLOATING SUPPLY VOLTAGE . . . 6 0 0 V
- OUTPUT CURRENT . . . + 1 2 0 mA / - 2 5 0 mA
- HALF BRIDGE DRIVER
- SOP-8

APPLICATIONS

MOSFET and IGBT module inverter driver for PDP, HID lamp, refrigerator, air-conditioner, washing machine, AC-servomotor and general purpose.

PIN CONFIGURATION (TOP VIEW)

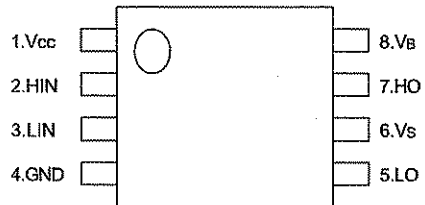

Outline : 8P2S

BLOCK DIAGRAM

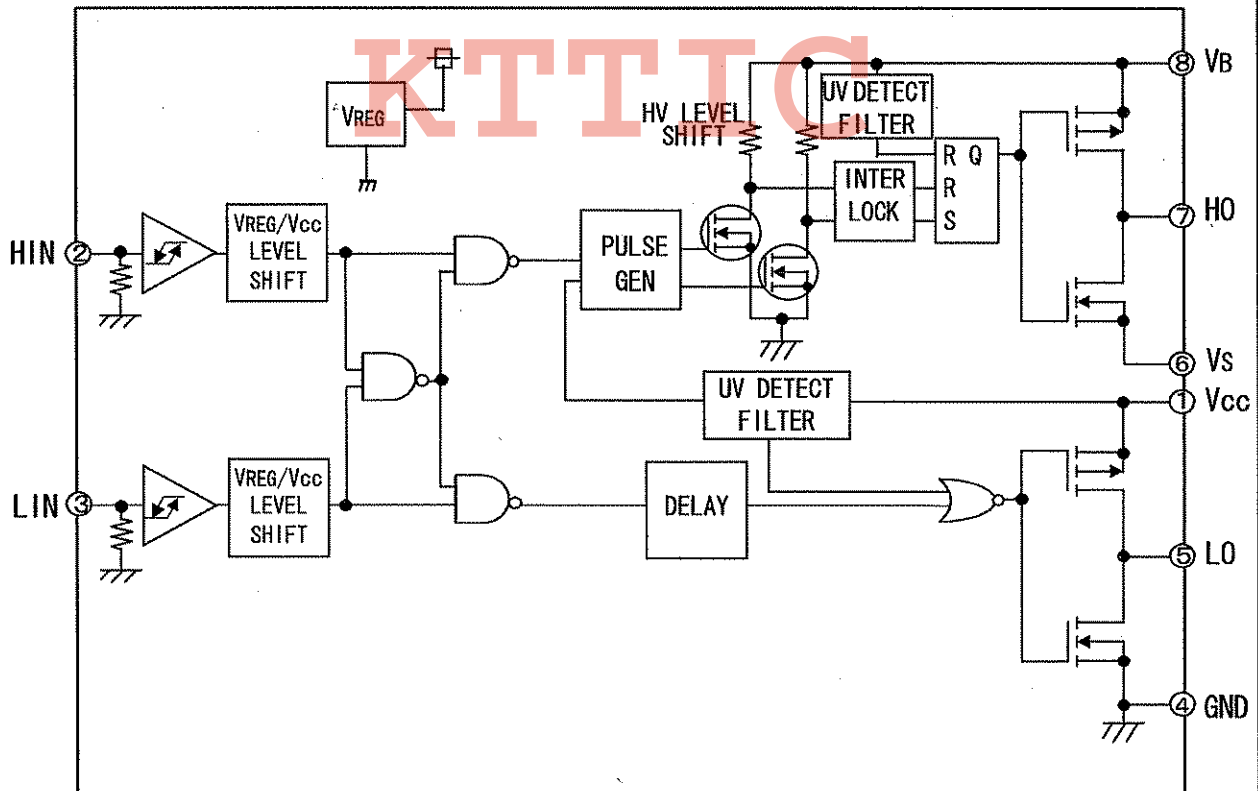

M81706AFP

HIGH VOLTAGE HALF BRIDGE DRIVER

ABSOLUTE MAXIMUM RATINGS

Symbol	Parameter	Test conditions	Ratings	Unit
V _B	High Side Floating Supply Absolute Voltage		-0.5~624	V
V _S	High Side Floating Supply Offset Voltage		V _B -24~V _B +0.5	V
V _{BS}	High Side Floating Supply Voltage	V _{BS} =V _B -V _S	-0.5~24	V
V _{HO}	High Side Output Voltage		V _S -0.5~V _B +0.5	V
V _{CC}	Low Side Fixed Supply Voltage		-0.5~24	V
V _{LO}	Low Side Output Voltage		-0.5~V _{CC} +0.5	V
V _{IN}	Logic Input Voltage	HIN, LIN	-0.5~V _{CC} +0.5	V
P _d	Package Power Dissipation	T _a =25°C, On Board	0.6	W
K _θ	Linear Derating Factor	T _a >25°C, On Board	6.0	mW/°C
R _{th(j-c)}	Junction - Case Thermal Resistance		50	°C/W
T _j	Junction Temperature		-20~125	°C
T _{opr}	Operation Temperature		-20~100	°C
T _{stg}	Storage Temperature		-40~125	°C

RECOMMENDED OPERATING CONDITIONS

Symbol	Parameter	Test conditions	Limits			Unit
			Min.	Typ.	Max.	
V _B	High Side Floating Supply Absolute Voltage		V _S +10	—	V _S +20	V
V _S	High Side Floating Supply Offset Voltage		0	—	500	V
V _{BS}	High Side Floating Supply Voltage	V _{BS} =V _B -V _S	10	—	20	V
V _{HO}	High Side Output Voltage		V _S	—	V _B	V
V _{CC}	Low Side Fixed Supply Voltage		10	—	20	V
V _{LO}	Logic Supply Voltage		0	—	V _{CC}	V
V _{IN}	Logic Input Voltage	HIN, LIN	0	—	V _{CC}	V

Thermal Derating Factor Characteristic

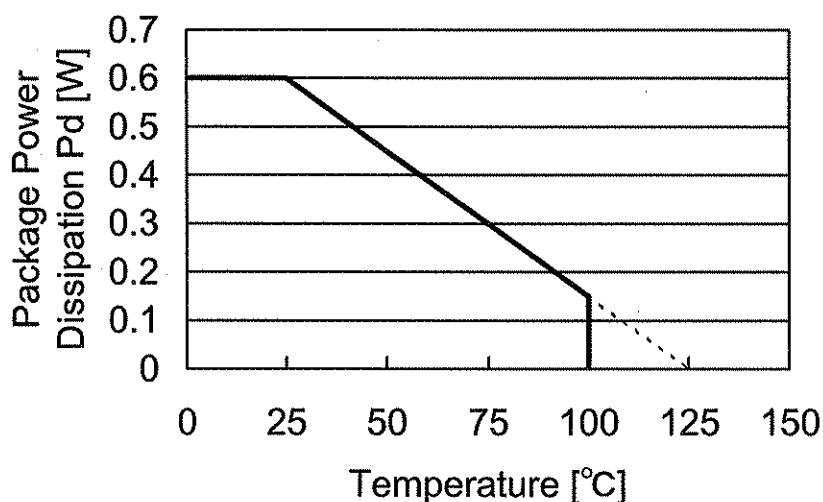

M81706AFP

HIGH VOLTAGE HALF BRIDGE DRIVER

ELECTRICAL CHARACTERISTICS (Ta = 25°C, Vcc=Vbs(=Vb-Vs)=15V, unless otherwise specified)

Symbol	Parameter	Test conditions	Limits			Unit
			Min.	Typ.*	Max.	
IFS	Floating Supply Leakage Current	Vb=Vs=600V	—	—	1.0	μA
IBS	VBS standby Current	HIN=LIN=0V	—	0.2	0.5	mA
ICC	Vcc standby Current	HIN=LIN=0V	0.2	0.5	1.0	mA
VOH	High Level Output Voltage	I _o =-20mA, LO, HO	13.6	14.2	—	V
VOL	Low Level Output Voltage	I _o =20mA, LO, HO	—	0.3	0.6	V
VIH	High Level Input Threshold Voltage	HIN, LIN	2.7	—	—	V
VIL	Low Level Input Threshold Voltage	HIN, LIN	—	—	0.8	V
I _{IH}	High Level Input Bias Current	VIN=5V	—	5	20	μA
I _{IL}	Low Level Input Bias Current	VIN=0V	—	—	2	μA
VBSuvr	Vbs Supply UV Reset Voltage		8.0	8.9	9.8	V
VBSuvt	Vbs Supply UV Trip Voltage		7.4	8.2	9.0	V
VBSuvh	Vbs Supply UV Hysteresis Voltage		0.5	0.7	—	V
tVBSuv	Vbs Supply UV Filter Time		—	7.5	—	μs
VCCUvr	Vcc Supply UV Reset Voltage		8.0	8.9	9.8	V
VCCUvt	Vcc Supply UV Trip Voltage		7.4	8.2	9.0	V
VCCUvh	Vcc Supply UV Hysteresis Voltage		0.5	0.7	—	V
tVCCUv	Vcc Supply UV Filter Time		—	7.5	—	μs
I _{OH}	Output High Level Short Circuit Pulsed Current	V _o =0V, V _{IN} =5V, PW<10 μs	120	200	—	mA
I _{OL}	Output Low Level Short Circuit Pulsed Current	V _o =15V, V _{IN} =0V, PW<10 μs	250	350	—	mA
R _{OH}	Output High Level On Resistance	I _o =-20mA, R _{OH} =(V _{OH} -V _o)/I _o	—	40	70	Ω
R _{OL}	Output Low Level On Resistance	I _o =20mA, R _{OL} =V _o /I _o	—	15	30	Ω
t _{dLH} (HO)	High Side Turn-On Propagation Delay	CL=1000pF between HO-Vs	—	120	240	ns
t _{dHL} (HO)	High Side Turn-Off Propagation Delay	CL=1000pF between HO-Vs	—	170	280	ns
t _{rH}	High Side Turn-On Rise Time	CL=1000pF between HO-Vs	—	130	220	ns
t _{fH}	High Side Turn-Off Fall Time	CL=1000pF between HO-Vs	—	50	80	ns
t _{dLH} (LO)	Low Side Turn-On Propagation Delay	CL=1000pF between LO-GND	—	120	240	ns
t _{dHL} (LO)	Low Side Turn-Off Propagation Delay	CL=1000pF between LO-GND	—	170	280	ns
t _{rL}	Low Side Turn-On Rise Time	CL=1000pF between LO-GND	—	130	220	ns
t _{fL}	Low Side Turn-Off Fall Time	CL=1000pF between LO-GND	—	50	80	ns
Δt _{dLH}	Delay Matching, High Side and Low Side Turn-On	t _{dLH} (HO)-t _{dLH} (LO)	—	0	30	ns
Δt _{dHL}	Delay Matching, High Side and Low Side Turn-Off	t _{dHL} (HO)-t _{dHL} (LO)	—	0	30	ns

*Typ. is not specified

FUNCTION TABLE (X : HorL)

HIN	LIN	V _{BS} UV	V _{CC} UV	HO	LO	Behavioral State
L	L	H	H	L	L	LO = HO = Low
L	H	H	H	L	H	LO = High
H	L	H	H	H	L	HO = High
H	H	H	H	L	L	LO = HO = Low
X	L	L	H	L	L	HO = Low, V _{BS} UV tripped
X	H	L	H	L	H	LO = High, V _{BS} UV tripped
L	X	H	L	L	L	LO = Low, V _{CC} UV tripped
H	X	H	L	L	L	HO = LO = Low, V _{CC} UV tripped

Note: "L" state of V_{BS} UV, V_{CC} UV means that UV trip voltage.

In the case of both input signals (HIN and LIN) are "H", output signals (HO and LO) become "L".

TIMING DIAGRAM

1. Input/Output Timing Diagram

HIGH ACTIVE(When input signal(HIN or LIN) is "H", then output signal (HO or LO) is "H".)

In the case of both input signals (HIN and LIN) are "H", output signals (HO and LO) become "L".

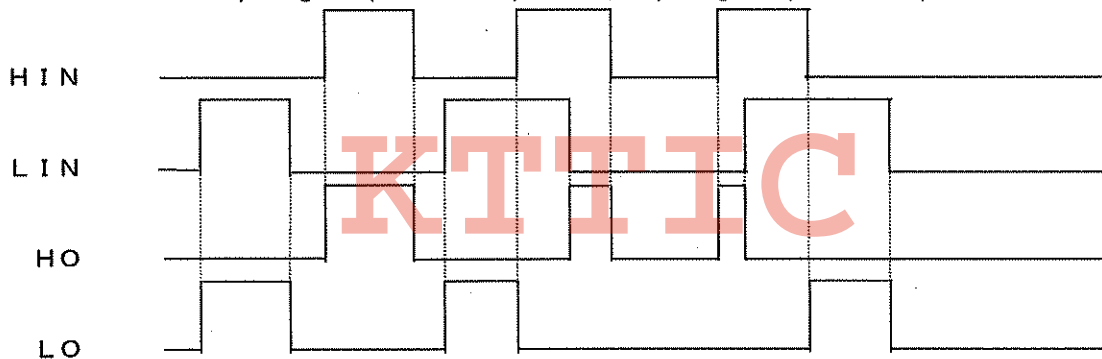

M81706AFP

HIGH VOLTAGE HALF BRIDGE DRIVER

2. Vcc(Vbs) Supply Under Voltage Lockout Timing Diagram

When Vcc Supply Voltage keeps lower UV Trip Voltage($V_{CCUVt} = V_{CCUVR} - V_{CCUVh}$) for Vcc Supply UV Filter Time, output signal becomes "L". And then, when Vcc Supply Voltage is higher than UV Reset Voltage, output signal LO becomes "H".

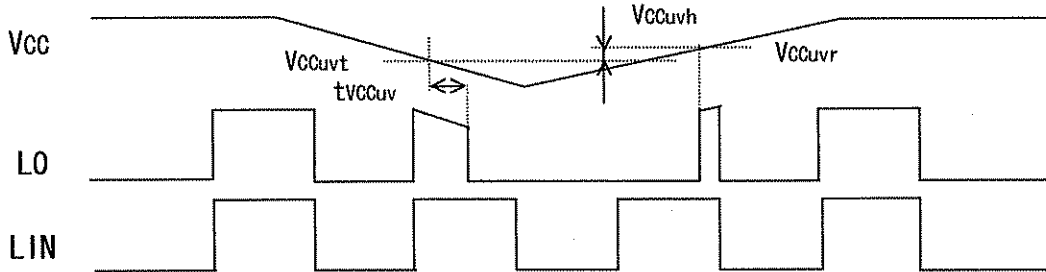

When Vcc Supply Voltage keeps lower UV Trip Voltage($V_{CCUVt} = V_{CCUVR} - V_{CCUVh}$) for Vcc Supply UV Filter Time, output signal becomes "L". And then, when Vcc Supply Voltage is higher than UV Reset Voltage, input signal (LIN) is L; output signal HO becomes "H".

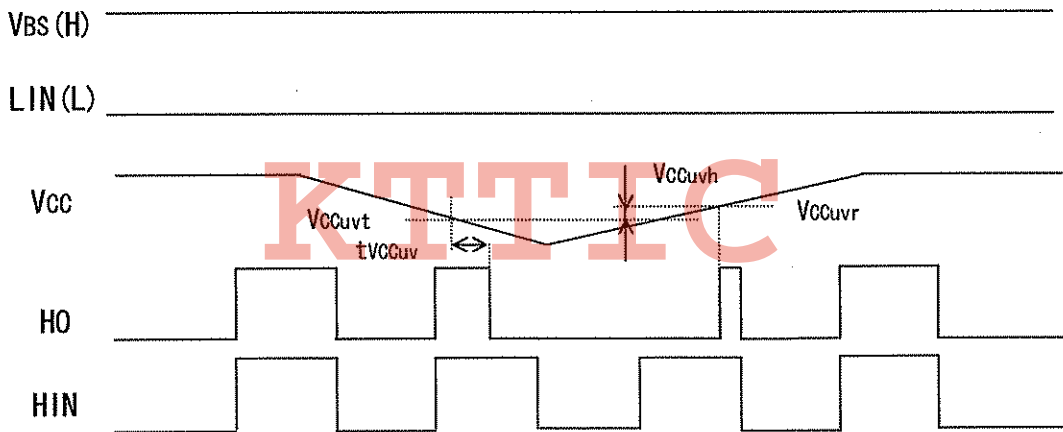

When Vbs Supply Voltage keeps lower UV Trip Voltage ($V_{BSUVt} = V_{BSUVR} - V_{BSUVh}$) for Vbs Supply UV Filter Time, output signal becomes "L". And then, Vbs Supply Voltage is higher than UV Reset Voltage, output signal HO keeps "L" until next input signal HIN is "H".

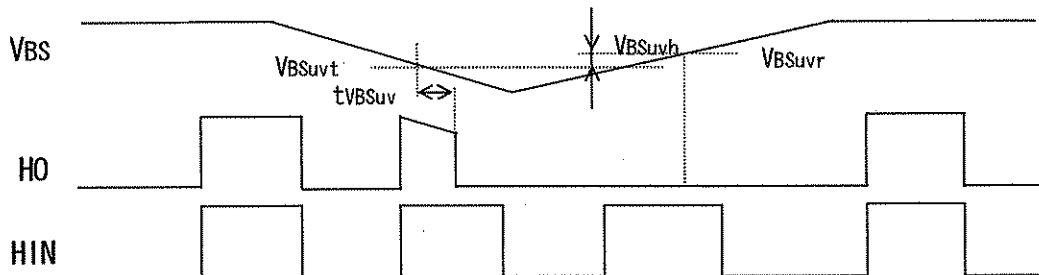

MITSUBISHI SEMICONDUCTORS [H V I C]

M81706AFP

HIGH VOLTAGE HALF BRIDGE DRIVER

3. Allowable supply voltage transient

It is recommended that supplying Vcc firstly and supplying Vbs secondly. In the case of shutting off supply voltage, shutting off Vbs firstly and shutting off Vcc secondly. At the time of starting Vcc and Vbs, power supply should be increased slowly. If it is increased rapidly, output signal (HO or LO) may be "H".

Consideration

As for this product, the terminal of low voltage part and high-voltage part is very clear (The Fifth: LO, The Sixth: Vs). Therefore, pin insulation space distance should be taken enough.

PACKAGE OUTLINE

