



# NAND128-A, NAND256-A NAND512-A, NAND01G-A

128 Mbit, 256 Mbit, 512 Mbit, 1 Gbit (x8/x16)  
528 Byte/264 Word Page, 1.8V/3V, NAND Flash Memories

## FEATURES SUMMARY

### ■ HIGH DENSITY NAND FLASH MEMORIES

- Up to 1 Gbit memory array
- Up to 32 Mbit spare area
- Cost effective solutions for mass storage applications

### ■ NAND INTERFACE

- x8 or x16 bus width
- Multiplexed Address/ Data
- Pinout compatibility for all densities

### ■ SUPPLY VOLTAGE

- 1.8V device:  $V_{DD} = 1.7$  to  $1.95V$
- 3.0V device:  $V_{DD} = 2.7$  to  $3.6V$

### ■ PAGE SIZE

- x8 device: (512 + 16 spare) Bytes
- x16 device: (256 + 8 spare) Words

### ■ BLOCK SIZE

- x8 device: (16K + 512 spare) Bytes
- x16 device: (8K + 256 spare) Words

### ■ PAGE READ / PROGRAM

- Random access:  $12\mu s$  (3V)/ $15\mu s$  (1.8V) (max)
- Sequential access: 50ns (min)
- Page program time:  $200\mu s$  (typ)

### ■ COPY BACK PROGRAM MODE

- Fast page copy without external buffering

### ■ FAST BLOCK ERASE

- Block erase time: 2ms (Typ)

### ■ STATUS REGISTER

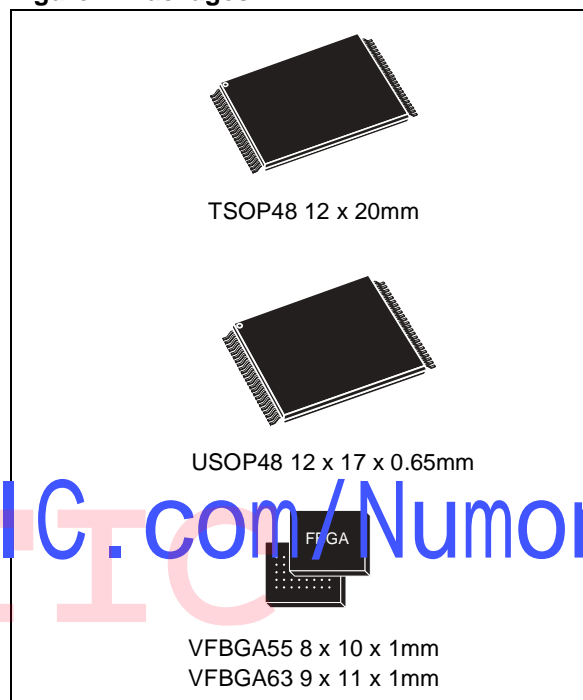
### ■ ELECTRONIC SIGNATURE

### ■ CHIP ENABLE 'DON'T CARE'

- Simple interface with microcontroller

### ■ SERIAL NUMBER OPTION

Figure 1. Packages



### ■ HARDWARE DATA PROTECTION

- Program/Erase locked during Power transitions

### ■ DATA INTEGRITY

- 100,000 Program/Erase cycles
- 10 years Data Retention

### ■ RoHS COMPLIANCE

- Lead-Free Components are Compliant with the RoHS Directive

### ■ DEVELOPMENT TOOLS

- Error Correction Code software and hardware models
- Bad Blocks Management and Wear Leveling algorithms
- File System OS Native reference software
- Hardware simulation models

**NAND128-A, NAND256-A, NAND512-A, NAND01G-A**

---

**Table 1. Product List**

Reference	Part Number
NAND128-A	NAND128W3A
NAND256-A <sup>(1)</sup>	NAND256R3A
	NAND256R4A
	NAND256W3A
	NAND256W4A
NAND512-A <sup>(1)</sup>	NAND512R3A
	NAND512W3A
	NAND512R4A
	NAND512W4A
NAND01G-A <sup>(2)</sup>	NAND01GR3A
	NAND01GW3A
	NAND01GR4A
	NAND01GW4A

Note: 1. x16 organization only available for MCP.  
2. 512Mb-A stacked, only available for MCP as a Die.

<http://www.BDTIC.com/Numonyx>

**TABLE OF CONTENTS**

**FEATURES SUMMARY** ..... 1

    Figure 1. Packages ..... 1

    Table 1. Product List ..... 2

**SUMMARY DESCRIPTION** ..... 7

    Table 2. Product Description ..... 8

    Figure 2. Logic Diagram ..... 8

    Table 3. Signal Names ..... 8

    Figure 3. Logic Block Diagram ..... 9

    Figure 4. TSOP48 and USOP48 Connections, x8 devices ..... 10

    Figure 5. TSOP48 and USOP48 Connections, x16 devices ..... 10

    Figure 6. FBGA55 Connections, x8 devices (Top view through package) ..... 11

    Figure 7. FBGA55 Connections, x16 devices (Top view through package) ..... 12

    Figure 8. FBGA63 Connections, x8 devices (Top view through package) ..... 13

    Figure 9. FBGA63 Connections, x16 devices (Top view through package) ..... 14

**MEMORY ARRAY ORGANIZATION** ..... 15

**Bad Blocks** ..... 15

    Table 4. Valid Blocks ..... 15

    Figure 10. Memory Array Organization ..... 15

**SIGNAL DESCRIPTIONS** ..... 16

    Inputs/Outputs (I/O0-I/O7) ..... 16

    Inputs/Outputs (I/O8-I/O15) ..... 16

    Address Latch Enable (AL) ..... 16

    Command Latch Enable (CL) ..... 16

    Chip Enable ( $\bar{E}$ ) ..... 16

    Read Enable ( $\bar{R}$ ) ..... 16

    Write Enable ( $\bar{W}$ ) ..... 16

    Write Protect ( $\bar{WP}$ ) ..... 16

    Ready/Busy ( $\bar{RB}$ ) ..... 16

    V<sub>DD</sub> Supply Voltage ..... 16

    V<sub>SS</sub> Ground ..... 16

**BUS OPERATIONS** ..... 17

**Command Input** ..... 17

**Address Input** ..... 17

**Data Input** ..... 17

**Data Output** ..... 17

**Write Protect** ..... 17

**Standby** ..... 17

    Table 5. Bus Operations ..... 17

    Table 6. Address Insertion, x8 Devices ..... 18

<http://www.kttic.com/Numonyx>



**NAND128-A, NAND256-A, NAND512-A, NAND01G-A**

Table 7. Address Insertion, x16 Devices .....	18
Table 8. Address Definitions .....	18
<b>COMMAND SET .....</b>	<b>19</b>
Table 9. Commands .....	19
<b>DEVICE OPERATIONS.....</b>	<b>20</b>
<b>Pointer Operations .....</b>	<b>20</b>
Figure 11.Pointer Operations .....	20
Figure 12.Pointer Operations for Programming.....	21
<b>Read Memory Array.....</b>	<b>22</b>
Random Read .....	22
Page Read.....	22
Figure 13.Read (A,B,C) Operations .....	22
Figure 14.Read Block Diagrams .....	23
<b>Page Program .....</b>	<b>24</b>
Figure 15.Page Program Operation .....	24
<b>Copy Back Program .....</b>	<b>25</b>
Table 10. Copy Back Program Addresses.....	25
Figure 16.Copy Back Operation .....	25
<b>Block Erase .....</b>	<b>26</b>
Figure 17.Block Erase Operation .....	26
<b>Reset.....</b>	<b>26</b>
<b>Read Status Register.....</b>	<b>27</b>
Write Protection Bit (SR7) .....	27
P/E/R Controller Bit (SR6).....	27
Error Bit (SR0).....	27
SR5, SR4, SR3, SR2 and SR1 are Reserved.....	27
Table 11. Status Register Bits .....	28
<b>Read Electronic Signature .....</b>	<b>28</b>
Table 12. Electronic Signature.....	28
<b>SOFTWARE ALGORITHMS .....</b>	<b>29</b>
<b>Bad Block Management .....</b>	<b>29</b>
<b>Block Replacement .....</b>	<b>29</b>
Table 13. Block Failure .....	29
Figure 18.Bad Block Management Flowchart .....	29
Figure 19.Garbage Collection .....	30
<b>Garbage Collection .....</b>	<b>30</b>
<b>Wear-leveling Algorithm .....</b>	<b>30</b>
<b>Error Correction Code.....</b>	<b>30</b>
Figure 20.Error Detection .....	30
<b>Hardware Simulation Models .....</b>	<b>31</b>
Behavioral simulation models .....	31
IBIS simulations models .....	31

**NAND128-A, NAND256-A, NAND512-A, NAND01G-A**

<b>PROGRAM AND ERASE TIMES AND ENDURANCE CYCLES</b> .....	<b>32</b>
Table 14. Program, Erase Times and Program Erase Endurance Cycles .....	32
<b>MAXIMUM RATING</b> .....	<b>32</b>
Table 15. Absolute Maximum Ratings .....	32
<b>DC and AC PARAMETERS</b> .....	<b>33</b>
Table 16. Operating and AC Measurement Conditions .....	33
Table 17. Capacitance .....	33
Table 18. DC Characteristics, 1.8V Devices .....	34
Figure 21. Equivalent Testing Circuit For AC Characteristics Measurement .....	34
Table 19. DC Characteristics, 3V Devices .....	35
Table 20. AC Characteristics for Command, Address, Data Input .....	36
Table 21. AC Characteristics for Operations .....	37
Figure 22. Command Latch AC Waveforms .....	38
Figure 23. Address Latch AC Waveforms .....	38
Figure 24. Data Input Latch AC Waveforms .....	39
Figure 25. Sequential Data Output after Read AC Waveforms .....	39
Figure 26. Read Status Register AC Waveform .....	40
Figure 27. Read Electronic Signature AC Waveform .....	40
Figure 28. Page Read A/ Read B Operation AC Waveform .....	41
Figure 29. Read C Operation, One Page AC Waveform .....	42
Figure 30. Page Program AC Waveform .....	43
Figure 31. Block Erase AC Waveform .....	44
Figure 32. Reset AC Waveform .....	44
<b>Ready/Busy Signal Electrical Characteristics</b> .....	<b>45</b>
Figure 33. Ready/Busy AC Waveform .....	45
Figure 34. Ready/Busy Load Circuit .....	45
Figure 35. Resistor Value Versus Waveform Timings For Ready/Busy Signal .....	45
<b>Data Protection</b> .....	<b>46</b>
Figure 36. Data Protection .....	46
<b>PACKAGE MECHANICAL</b> .....	<b>47</b>
Figure 37. TSOP48 - 48 lead Plastic Thin Small Outline, 12 x 20mm, Package Outline .....	47
Table 22. TSOP48 - 48 lead Plastic Thin Small Outline, 12 x 20mm, Package Mechanical Data .....	47
Figure 38. USOP48 – lead Plastic Ultra Thin Small Outline, 12 x 17mm, Package Outline .....	48
Table 23. USOP48 – lead Plastic Ultra Thin Small Outline, 12 x 17mm, Package Mechanical Data .....	48
Figure 39. VFBGA55 8 x 10mm - 6x8 active ball array, 0.80mm pitch, Package Outline .....	49
Table 24. VFBGA55 8 x 10mm - 6x8 ball array, 0.80mm pitch, Package Mechanical Data .....	49
Figure 40. VFBGA63 9x11mm - 6x8 active ball array, 0.80mm pitch, Package Outline .....	50
Table 25. VFBGA63 9x11mm - 6x8 active ball array, 0.80mm pitch, Package Mechanical Data .....	50
<b>PART NUMBERING</b> .....	<b>51</b>
Table 26. Ordering Information Scheme .....	51

**NAND128-A, NAND256-A, NAND512-A, NAND01G-A**

---

**APPENDIX A.HARDWARE INTERFACE EXAMPLES . . . . . 52**

    Figure 41.Connection to Microcontroller, Without Glue Logic . . . . . 52

    Figure 42.Connection to Microcontroller, With Glue Logic . . . . . 53

    Figure 43.Building Storage Modules . . . . . 53

**RELATED DOCUMENTATION . . . . . 53**

**REVISION HISTORY . . . . . 54**

    Table 27. Document Revision History . . . . . 54

<http://www.BDTIC.com/Numonyx>

**SUMMARY DESCRIPTION**

The NAND Flash 528 Byte/ 264 Word Page is a family of non-volatile Flash memories that uses the Single Level Cell (SLC) NAND cell technology. It is referred to as the Small Page family. The devices range from 128Mbits to 1Gbit and operate with either a 1.8V or 3V voltage supply. The size of a Page is either 528 Bytes (512 + 16 spare) or 264 Words (256 + 8 spare) depending on whether the device has a x8 or x16 bus width.

The address lines are multiplexed with the Data Input/Output signals on a multiplexed x8 or x16 Input/Output bus. This interface reduces the pin count and makes it possible to migrate to other densities without changing the footprint.

Each block can be programmed and erased over 100,000 cycles. To extend the lifetime of NAND Flash devices it is strongly recommended to implement an Error Correction Code (ECC). A Write Protect pin is available to give a hardware protection against program and erase operations.

The devices feature an open-drain Ready/Busy output that can be used to identify if the Program/Erase/Read (P/E/R) Controller is currently active. The use of an open-drain output allows the Ready/Busy pins from several memories to be connected to a single pull-up resistor.

A Copy Back command is available to optimize the management of defective blocks. When a Page Program operation fails, the data can be pro-

grammed in another page without having to resend the data to be programmed.

The devices are available in the following packages:

- TSOP48 12 x 20mm for all products
- USOP48 12 x 17 x 0.65mm for 128Mb, 256Mb and 512Mb products
- VFBGA55 (8 x 10 x 1mm, 6 x 8 ball array, 0.8mm pitch) for 128Mb and 256Mb products
- VFBGA63 (9 x 11 x 1mm, 6 x 8 ball array, 0.8mm pitch) for the 512Mb product

All devices have the Chip Enable Don't Care option, which allows the code to be directly downloaded by a microcontroller, as Chip Enable transitions during the latency time do not stop the read operation.

A Serial Number option, allows each device to be uniquely identified. The Serial Number options is subject to an NDA (Non Disclosure Agreement) and so not described in the datasheet. For more details of this option contact your nearest ST Sales office.

For information on how to order these options refer to [Table 26., Ordering Information Scheme](#). Devices are shipped from the factory with Block 0 always valid and the memory content bits, in valid blocks, erased to "1".

See [Table 2., Product Description](#), for all the de-

<http://www.kttic.com/Numonyx>

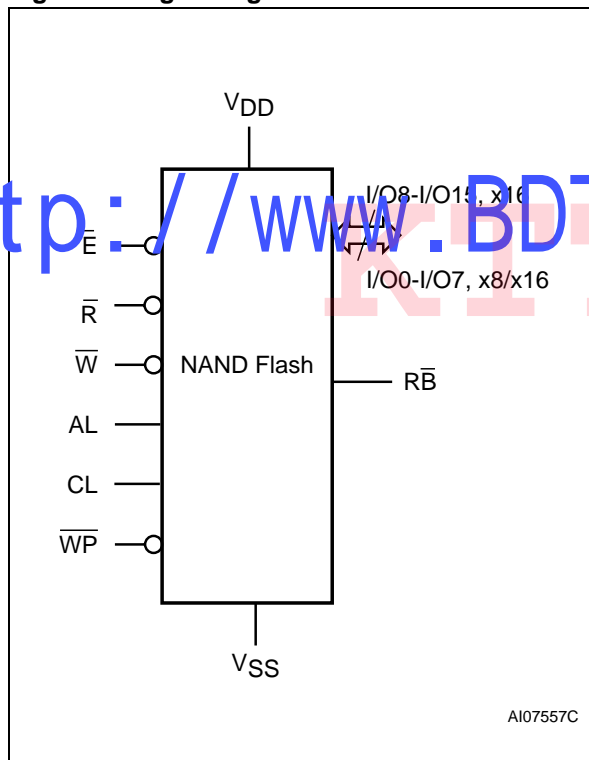
**NAND128-A, NAND256-A, NAND512-A, NAND01G-A**

**Table 2. Product Description**

Reference	Part Number	Density	Bus Width	Page Size	Block Size	Memory Array	Operating Voltage	Timings				Package
								Random Access Max	Sequential Access Min	Page Program Typical	Block Erase Typical	
NAND128-A	NAND128W3A	128Mbit	x8	512+16 Bytes	16K+512 Bytes	32 Pages x 1024 Blocks	2.7 to 3.6V	12µs	50ns	200µs	2ms	TSOP48 USOP48
NAND256-A <sup>(1)</sup>	NAND256R3A	256Mbit	x8	512+16 Bytes	16K+512 Bytes	32 Pages x 2048 Blocks	1.7 to 1.95V	12µs	60ns	200µs	2ms	TSOP48 USOP48 VFPGA55
	NAND256W3A						2.7 to 3.6V	12µs	50ns	200µs		
	NAND256R4A		1.7 to 1.95V	12µs	60ns		200µs					
	NAND256W4A		2.7 to 3.6V	12µs	50ns		200µs					
NAND512-A <sup>(1)</sup>	NAND512R3A	512Mbit	x8	512+16 Bytes	16K+512 Bytes	32 Pages x 4096 Blocks	1.7 to 1.95V	15µs	60ns	200µs	2ms	TSOP48 USOP48 VFPGA63
	NAND512W3A						2.7 to 3.6V	12µs	50ns	200µs		
	NAND512R4A		1.7 to 1.95V	15µs	60ns		200µs					
	NAND512W4A		2.7 to 3.6V	12µs	50ns		200µs					
NAND01G-A <sup>(2)</sup>	NAND01GR3A	1Gbit	x8	512+16 Bytes	16K+512 Bytes	32 Pages x 8192 Blocks	1.7 to 1.95V	15µs	60ns	200µs	2ms	Die for MCP
	NAND01GW3A						2.7 to 3.6V	12µs	50ns	200µs		
	NAND01GR4A		1.7 to 1.95V	15µs	60ns		200µs					
	NAND01GW4A		2.7 to 3.6V	12µs	50ns		200µs					

Note: 1. x16 organization only available for MCP.  
 2. 512Mb-A stacked, only available for MCP as Die

**Figure 2. Logic Diagram**



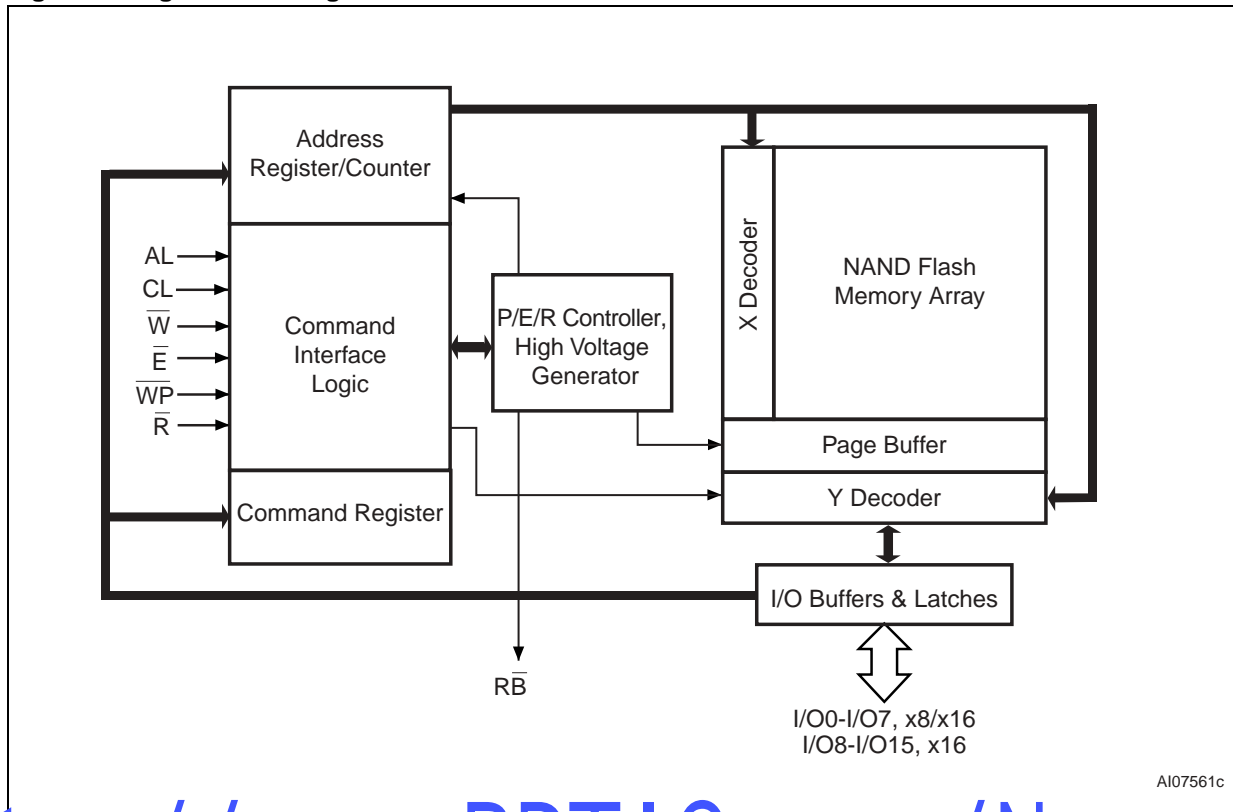
**Table 3. Signal Names**

I/O8-15	Data Input/Outputs for x16 devices
I/O0-7	Data Input/Outputs, Address Inputs, or Command Inputs for x8 and x16 devices
AL	Address Latch Enable
CL	Command Latch Enable
E-bar	Chip Enable
R-bar	Read Enable
RB-bar	Ready/Busy (open-drain output)
W-bar	Write Enable
WP-bar	Write Protect
VDD	Supply Voltage
VSS	Ground
NC	Not Connected Internally
DU	Do Not Use



NAND128-A, NAND256-A, NAND512-A, NAND01G-A

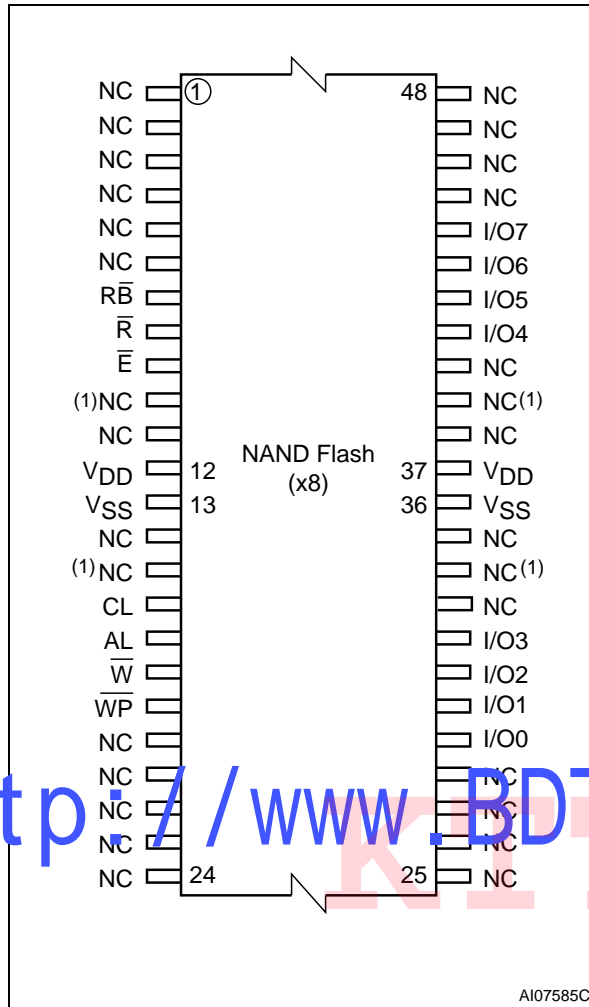
Figure 3. Logic Block Diagram



<http://www.BDTIC.com/Numonyx>

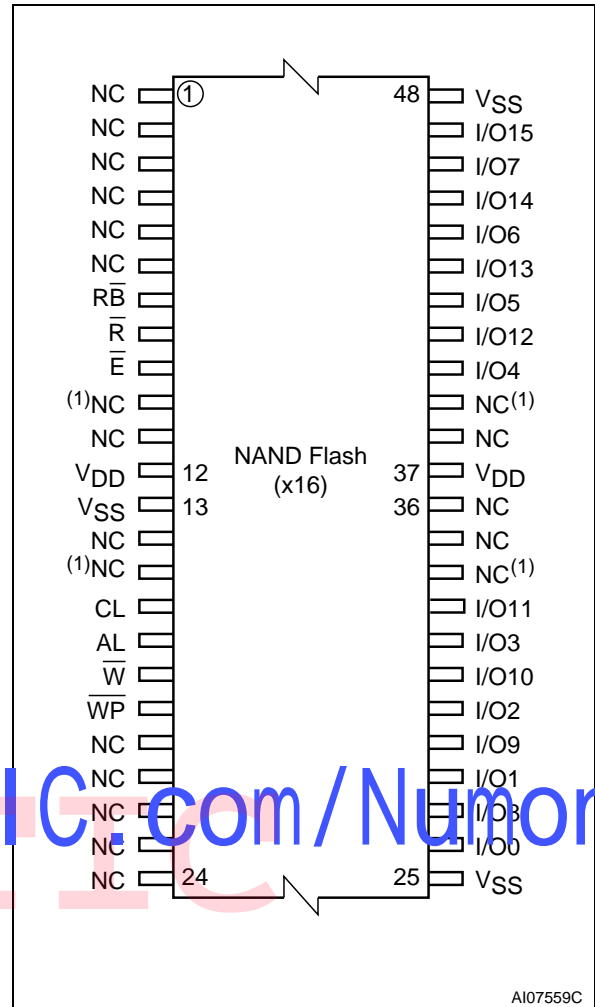
**NAND128-A, NAND256-A, NAND512-A, NAND01G-A**

**Figure 4. TSOP48 and USOP48 Connections, x8 devices**



Note: 1. This pin is DU in the USOP48 package

**Figure 5. TSOP48 and USOP48 Connections, x16 devices**

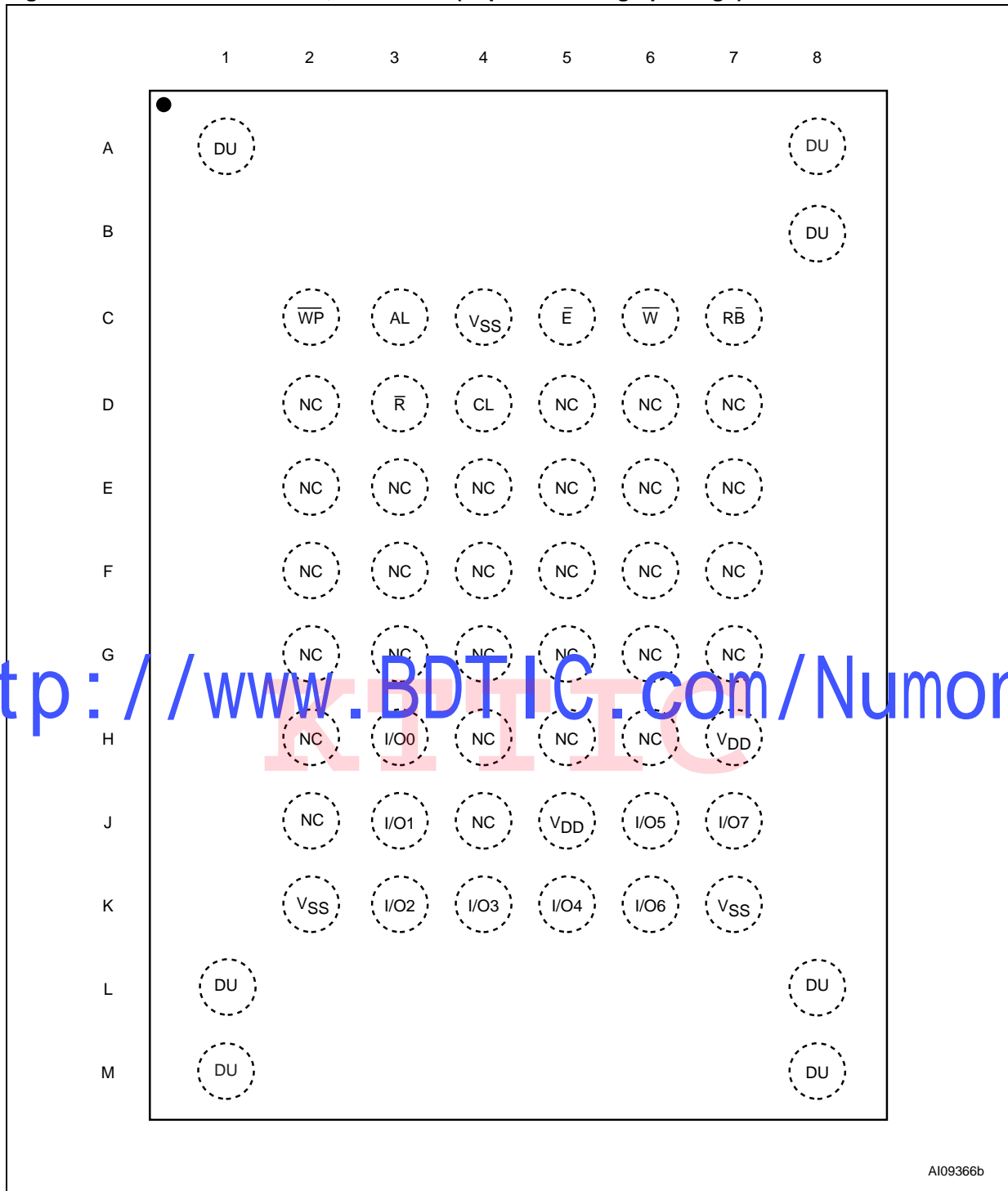


Note: 1. This pin is DU in the USOP48 package

<http://www.kttic.com/Numonyx>

NAND128-A, NAND256-A, NAND512-A, NAND01G-A

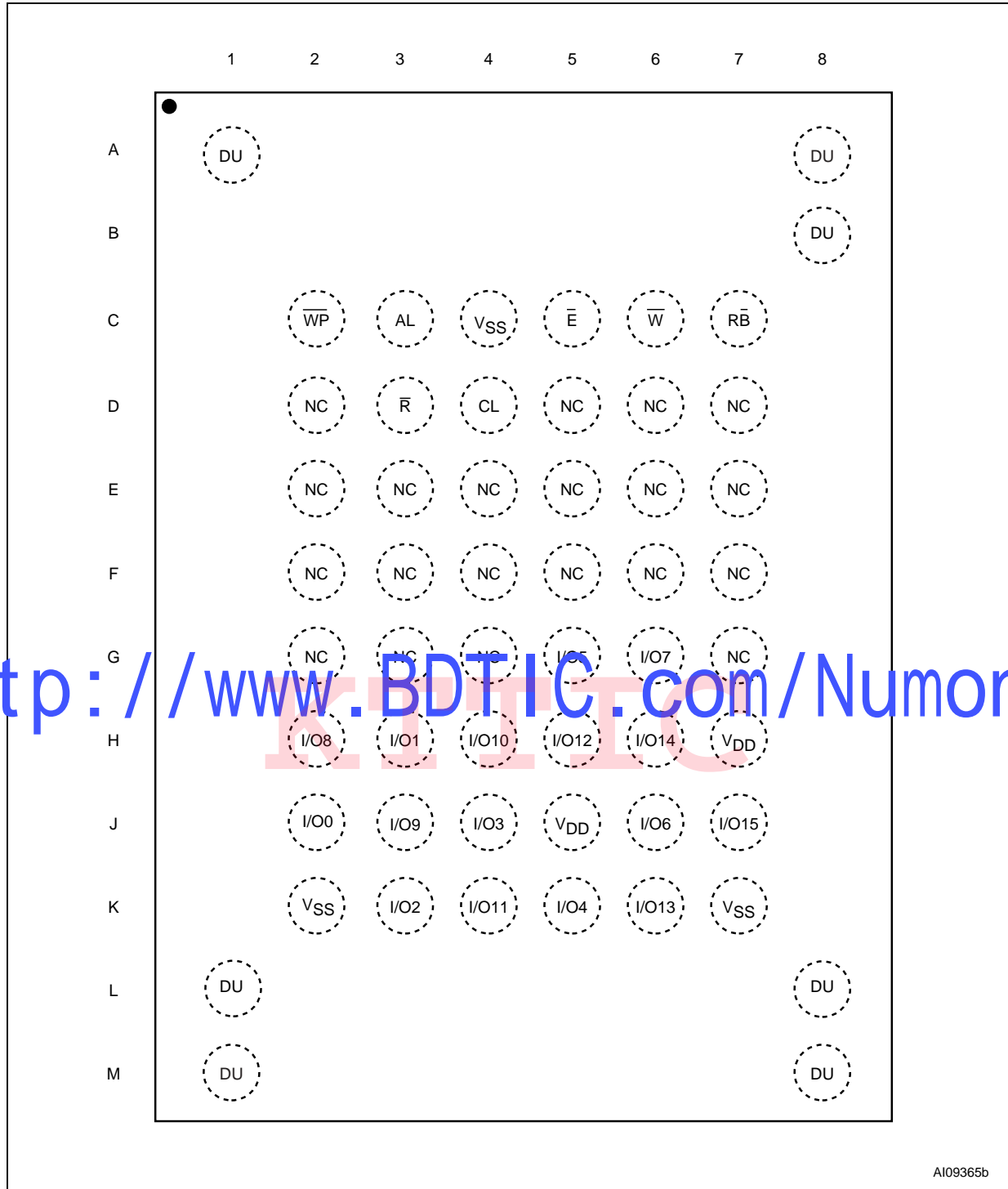
Figure 6. FBGA55 Connections, x8 devices (Top view through package)



A109366b

**NAND128-A, NAND256-A, NAND512-A, NAND01G-A**

**Figure 7. FBGA55 Connections, x16 devices (Top view through package)**



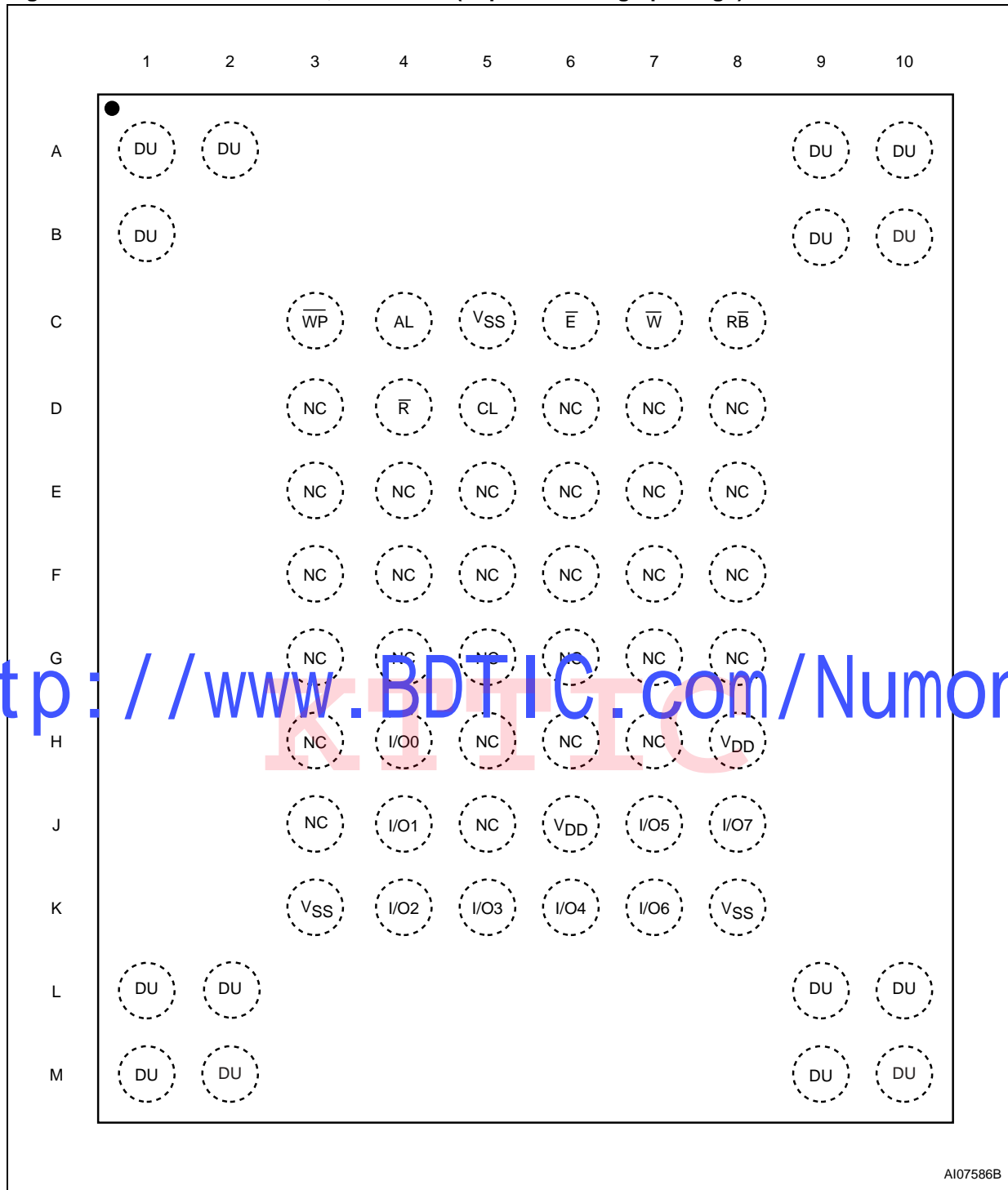
AI09365b

<http://www.BDTIC.com/Numonyx>



NAND128-A, NAND256-A, NAND512-A, NAND01G-A

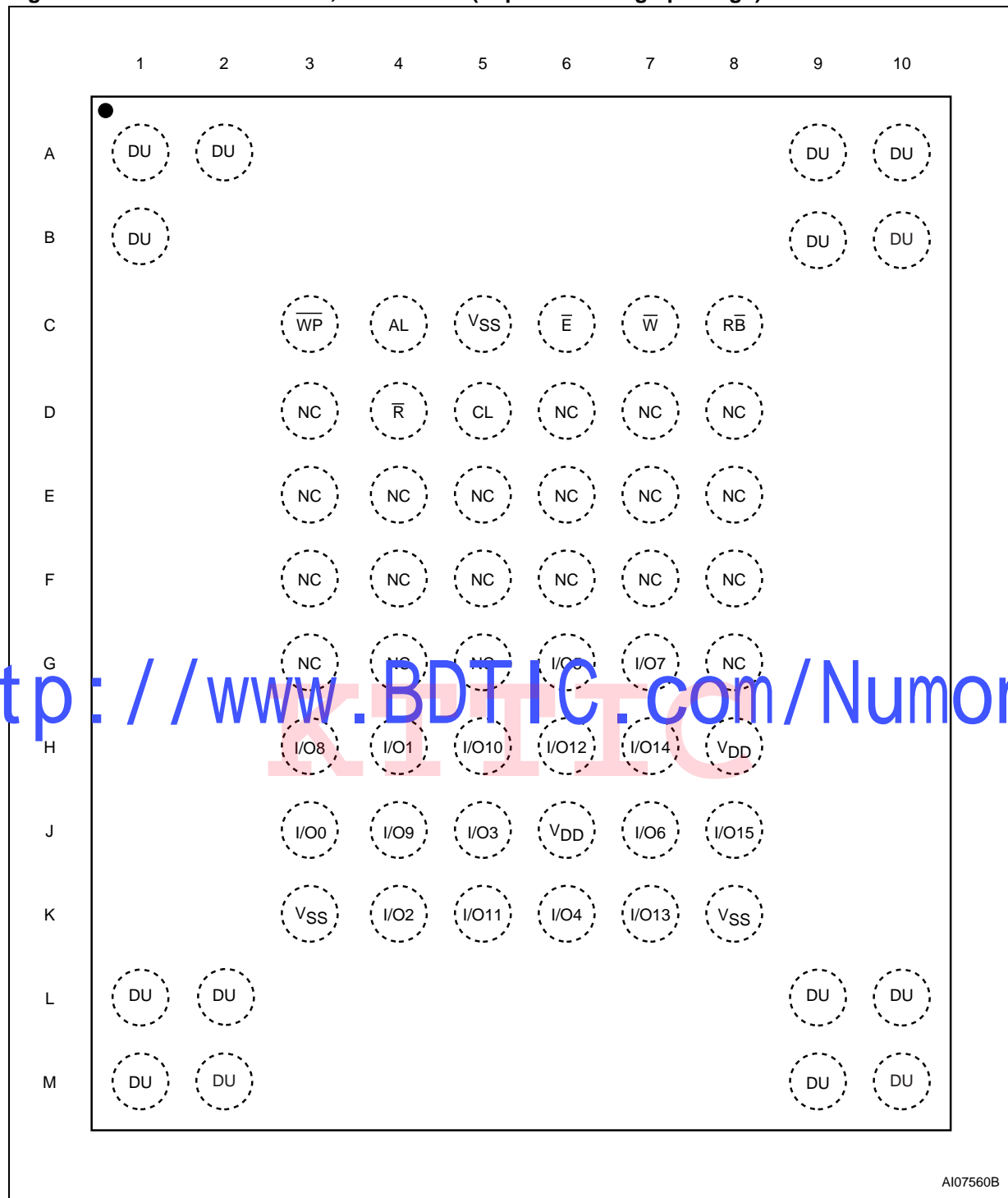
Figure 8. FBGA63 Connections, x8 devices (Top view through package)



<http://www.BDTIC.com/Numonyx>

**NAND128-A, NAND256-A, NAND512-A, NAND01G-A**

**Figure 9. FBGA63 Connections, x16 devices (Top view through package)**



<http://www.BDTIC.com/Numonyx>



**NAND128-A, NAND256-A, NAND512-A, NAND01G-A**

**MEMORY ARRAY ORGANIZATION**

The memory array is made up of NAND structures where 16 cells are connected in series.

The memory array is organized in blocks where each block contains 32 pages. The array is split into two areas, the main area and the spare area. The main area of the array is used to store data whereas the spare area is typically used to store Error correction Codes, software flags or Bad Block identification.

In x8 devices the pages are split into a main area with two half pages of 256 Bytes each and a spare area of 16 Bytes. In the x16 devices the pages are split into a 256 Word main area and an 8 Word spare area. Refer to [Figure 10., Memory Array Organization.](#)

**Bad Blocks**

The NAND Flash 528 Byte/ 264 Word Page devices may contain Bad Blocks, that is blocks that contain one or more invalid bits whose reliability is not guaranteed. Additional Bad Blocks may develop during the lifetime of the device.

The Bad Block Information is written prior to shipping (refer to [Bad Block Management](#) section for more details).

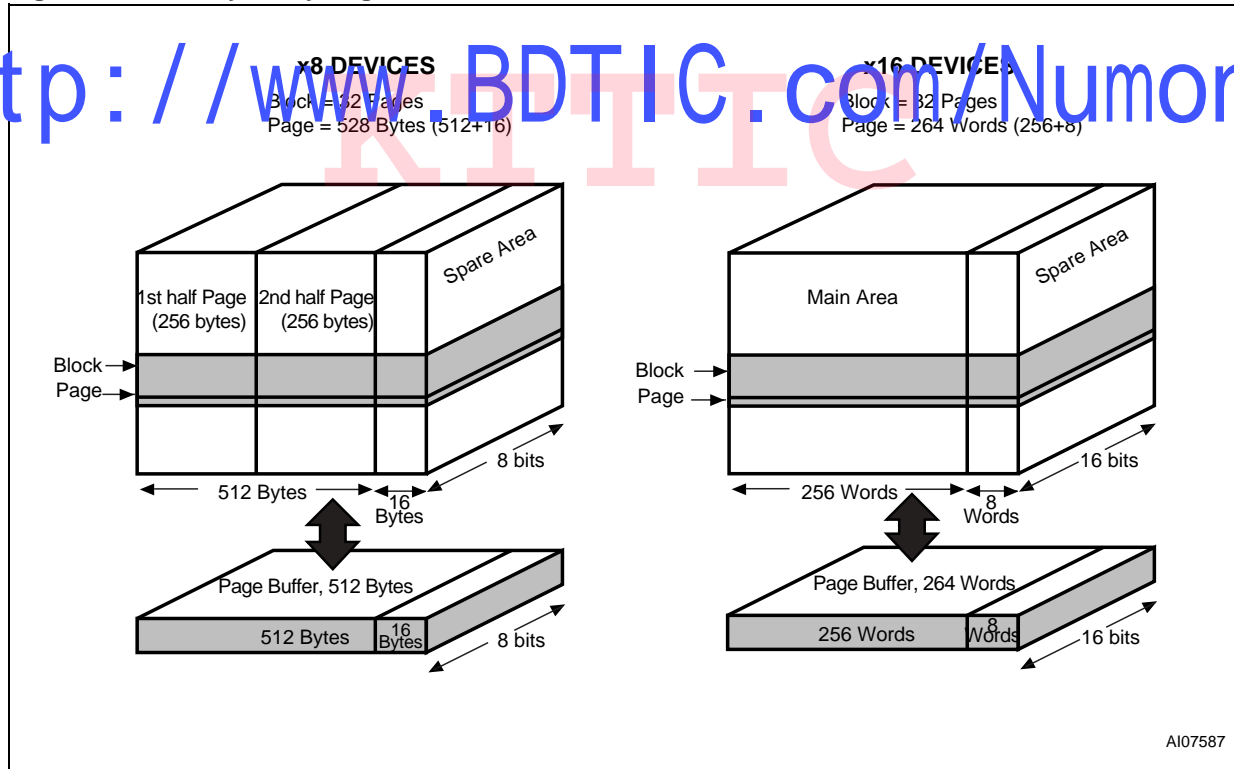
[Table 4.](#) shows the minimum number of valid blocks in each device. The values shown include both the Bad Blocks that are present when the device is shipped and the Bad Blocks that could develop later on.

These blocks need to be managed using Bad Blocks Management, Block Replacement or Error Correction Codes (refer to [SOFTWARE ALGORITHM](#) section).

**Table 4. Valid Blocks**

Density of Device	Min	Max
1Gbit	8032	8192
512Mbits	4016	4096
256Mbits	2008	2048
128Mbits	1004	1024

**Figure 10. Memory Array Organization**



**NAND128-A, NAND256-A, NAND512-A, NAND01G-A****SIGNAL DESCRIPTIONS**

See [Figure 2., Logic Diagram](#), and [Table 3., Signal Names](#), for a brief overview of the signals connected to this device.

**Inputs/Outputs (I/O0-I/O7).** Input/Outputs 0 to 7 are used to input the selected address, output the data during a Read operation or input a command or data during a Write operation. The inputs are latched on the rising edge of Write Enable. I/O0-I/O7 are left floating when the device is deselected or the outputs are disabled.

**Inputs/Outputs (I/O8-I/O15).** Input/Outputs 8 to 15 are only available in x16 devices. They are used to output the data during a Read operation or input data during a Write operation. Command and Address Inputs only require I/O0 to I/O7.

The inputs are latched on the rising edge of Write Enable. I/O8-I/O15 are left floating when the device is deselected or the outputs are disabled.

**Address Latch Enable (AL).** The Address Latch Enable activates the latching of the Address inputs in the Command Interface. When AL is high, the inputs are latched on the rising edge of Write Enable.

**Command Latch Enable (CL).** The Command Latch Enable activates the latching of the Command inputs in the Command Interface. When CL is high, the inputs are latched on the rising edge of Write Enable.

**Chip Enable ( $\bar{E}$ ).** The Chip Enable input activates the memory control logic, input buffers, decoders and read circuitry. When Chip Enable is low,  $V_{IL}$ , the device is selected.

If Chip Enable goes High ( $V_{IH}$ ) while the device is busy, the device remains selected and does not go into standby mode.

**Read Enable ( $\bar{R}$ ).** The Read Enable,  $\bar{R}$ , controls the sequential data output during Read operations. Data is valid  $t_{RLQV}$  after the falling edge of  $\bar{R}$ . The falling edge of  $\bar{R}$  also increments the internal column address counter by one.

**Write Enable ( $\bar{W}$ ).** The Write Enable input,  $\bar{W}$ , controls writing to the Command Interface, Input Address and Data latches. Both addresses and

data are latched on the rising edge of Write Enable.

During power-up and power-down a recovery time of 10 $\mu$ s (min) is required before the Command Interface is ready to accept a command. It is recommended to keep Write Enable high during the recovery time.

**Write Protect ( $\bar{WP}$ ).** The Write Protect pin is an input that gives a hardware protection against unwanted program or erase operations. When Write Protect is Low,  $V_{IL}$ , the device does not accept any program or erase operations.

It is recommended to keep the Write Protect pin Low,  $V_{IL}$ , during power-up and power-down.

**Ready/Busy ( $\bar{RB}$ ).** The Ready/Busy output,  $\bar{RB}$ , is an open-drain output that can be used to identify if the P/E/R Controller is currently active.

When Ready/Busy is Low,  $V_{OL}$ , a read, program or erase operation is in progress. When the operation completes Ready/Busy goes High,  $V_{OH}$ .

The use of an open-drain output allows the Ready/Busy pins from several memories to be connected to a single pull-up resistor. A Low will then indicate that one, or more, of the memories is busy.

Refer to the [Ready/Busy Signal Electrical Characteristics](#) section for details on how to calculate the value of the pull-up resistor.

**$V_{DD}$  Supply Voltage.**  $V_{DD}$  provides the power supply to the internal core of the memory device. It is the main power supply for all operations (read, program and erase).

An internal voltage detector disables all functions whenever  $V_{DD}$  is below the  $V_{LKO}$  threshold (see paragraph [Figure 36., Data Protection](#)) to protect the device from any involuntary Program/Erase operations during power-transitions.

Each device in a system should have  $V_{DD}$  decoupled with a 0.1 $\mu$ F capacitor. The PCB track widths should be sufficient to carry the required program and erase currents

**$V_{SS}$  Ground.** Ground,  $V_{SS}$ , is the reference for the power supply. It must be connected to the system ground.



## BUS OPERATIONS

There are six standard bus operations that control the memory. Each of these is described in this section, see [Table 5., Bus Operations](#), for a summary.

### Command Input

Command Input bus operations are used to give commands to the memory. Command are accepted when Chip Enable is Low, Command Latch Enable is High, Address Latch Enable is Low and Read Enable is High. They are latched on the rising edge of the Write Enable signal.

Only I/O0 to I/O7 are used to input commands.

See [Figure 22.](#) and [Table 20.](#) for details of the timings requirements.

### Address Input

Address Input bus operations are used to input the memory address. Three bus cycles are required to input the addresses for the 128Mb and 256Mb devices and four bus cycles are required to input the addresses for the 512Mb and 1Gb devices (refer to [Tables 6 and 7,](#) Address Insertion).

The addresses are accepted when Chip Enable is Low, Address Latch Enable is High, Command Latch Enable is Low and Read Enable is High. They are latched on the rising edge of the Write Enable signal. Only I/O0 to I/O7 are used to input addresses.

See [Figure 23.](#) and [Table 20.](#) for details of the timings requirements.

### Data Input

Data Input bus operations are used to input the data to be programmed.

Data is accepted only when Chip Enable is Low, Address Latch Enable is Low, Command Latch Enable is Low and Read Enable is High. The data is latched on the rising edge of the Write Enable signal. The data is input sequentially using the Write Enable signal.

See [Figure 24.](#) and [Table 20.](#) and [Table 21.](#) for details of the timings requirements.

### Data Output

Data Output bus operations are used to read: the data in the memory array, the Status Register, the Electronic Signature and the Serial Number.

Data is output when Chip Enable is Low, Write Enable is High, Address Latch Enable is Low, and Command Latch Enable is Low.

The data is output sequentially using the Read Enable signal.

See [Figure 25.](#) and [Table 21.](#) for details of the timings requirements.

### Write Protect

Write Protect bus operations are used to protect the memory against program or erase operations. When the Write Protect signal is Low the device will not accept program or erase operations and so the contents of the memory array cannot be altered. The Write Protect signal is not latched by Write Enable to ensure protection even during power-up.

### Standby

When Chip Enable is High the memory enters Standby mode, the device is deselected, outputs are disabled and power consumption is reduced.

**Table 5. Bus Operations**

Bus Operation	$\bar{E}$	AL	CL	$\bar{R}$	$\bar{W}$	$\bar{WP}$	I/O0 - I/O7	I/O8 - I/O15 <sup>(1)</sup>
Command Input	V <sub>IL</sub>	V <sub>IL</sub>	V <sub>IH</sub>	V <sub>IH</sub>	Rising	X <sup>(2)</sup>	Command	X
Address Input	V <sub>IL</sub>	V <sub>IH</sub>	V <sub>IL</sub>	V <sub>IH</sub>	Rising	X	Address	X
Data Input	V <sub>IL</sub>	V <sub>IL</sub>	V <sub>IL</sub>	V <sub>IH</sub>	Rising	X	Data Input	Data Input
Data Output	V <sub>IL</sub>	V <sub>IL</sub>	V <sub>IL</sub>	Falling	V <sub>IH</sub>	X	Data Output	Data Output
Write Protect	X	X	X	X	X	V <sub>IL</sub>	X	X
Standby	V <sub>IH</sub>	X	X	X	X	X	X	X

Note: 1. Only for x16 devices.

2. WP must be V<sub>IH</sub> when issuing a program or erase command.

**NAND128-A, NAND256-A, NAND512-A, NAND01G-A**

**Table 6. Address Insertion, x8 Devices**

Bus Cycle	I/O7	I/O6	I/O5	I/O4	I/O3	I/O2	I/O1	I/O0
1 <sup>st</sup>	A7	A6	A5	A4	A3	A2	A1	A0
2 <sup>nd</sup>	A16	A15	A14	A13	A12	A11	A10	A9
3 <sup>rd</sup>	A24	A23	A22	A21	A20	A19	A18	A17
4 <sup>th</sup> (4)	V <sub>IL</sub>	V <sub>IL</sub>	V <sub>IL</sub>	V <sub>IL</sub>	V <sub>IL</sub>	V <sub>IL</sub>	A26	A25

Note: 1. A8 is set Low or High by the 00h or 01h Command, see [Pointer Operations](#) section.  
 2. Any additional address input cycles will be ignored.  
 3. The 4th cycle is only required for 512Mb and 1Gb devices.

**Table 7. Address Insertion, x16 Devices**

Bus Cycle	I/O8-I/O15	I/O7	I/O6	I/O5	I/O4	I/O3	I/O2	I/O1	I/O0
1 <sup>st</sup>	X	A7	A6	A5	A4	A3	A2	A1	A0
2 <sup>nd</sup>	X	A16	A15	A14	A13	A12	A11	A10	A9
3 <sup>rd</sup>	X	A24	A23	A22	A21	A20	A19	A18	A17
4 <sup>th</sup> (4)	X	V <sub>IL</sub>	V <sub>IL</sub>	V <sub>IL</sub>	V <sub>IL</sub>	V <sub>IL</sub>	V <sub>IL</sub>	A26	A25

Note: 1. A8 is Don't Care in x16 devices.  
 2. Any additional address input cycles will be ignored.  
 3. The 01h Command is not used in x16 devices.  
 4. The 4th cycle is only required for 512Mb and 1Gb devices.

**Table 8. Address Definitions**

Address	Definition
A0 - A7	Column Address
A9 - A26	Page Address
A9 - A13	Address in Block
A14 - A26	Block Address
A8	A8 is set Low or High by the 00h or 01h Command, and is Don't Care in x16 devices

<http://www.BDTIC.com/Numonyx>



**COMMAND SET**

All bus write operations to the device are interpreted by the Command Interface. The Commands are input on I/O0-I/O7 and are latched on the rising edge of Write Enable when the Command Latch Enable signal is high. Device operations are selected by writing specific commands to the Com-

mand Register. The two-step command sequences for program and erase operations are imposed to maximize data security.

The Commands are summarized in [Table 9., Commands.](#)

**Table 9. Commands**

Command	Bus Write Operations <sup>(1)</sup>			Command accepted during busy
	1 <sup>st</sup> CYCLE	2 <sup>nd</sup> CYCLE	3 <sup>rd</sup> CYCLE	
Read A	00h	-	-	
Read B	01h <sup>(2)</sup>	-	-	
Read C	50h	-	-	
Read Electronic Signature	90h	-	-	
Read Status Register	70h	-	-	Yes
Page Program	80h	10h	-	
Copy Back Program	00h	8Ah	10h	
Block Erase	60h	D0h	-	
Reset	FFh	-	-	Yes

Note: 1. The bus cycles are only shown for issuing the codes. The cycles required to input the addresses or input/output data are not shown.

2. Any undefined command sequence will be ignored by the device.

<http://www.BDTIC.com/Numonyx>

**NAND128-A, NAND256-A, NAND512-A, NAND01G-A**

**DEVICE OPERATIONS**

**Pointer Operations**

As the NAND Flash memories contain two different areas for x16 devices and three different areas for x8 devices (see [Figure 11.](#)) the read command codes (00h, 01h, 50h) are used to act as pointers to the different areas of the memory array (they select the most significant column address).

The Read A and Read B commands act as pointers to the main memory area. Their use depends on the bus width of the device.

- In x16 devices the Read A command (00h) sets the pointer to Area A (the whole of the main area) that is Words 0 to 255.
- In x8 devices the Read A command (00h) sets the pointer to Area A (the first half of the main area) that is Bytes 0 to 255, and the Read B command (01h) sets the pointer to Area B (the

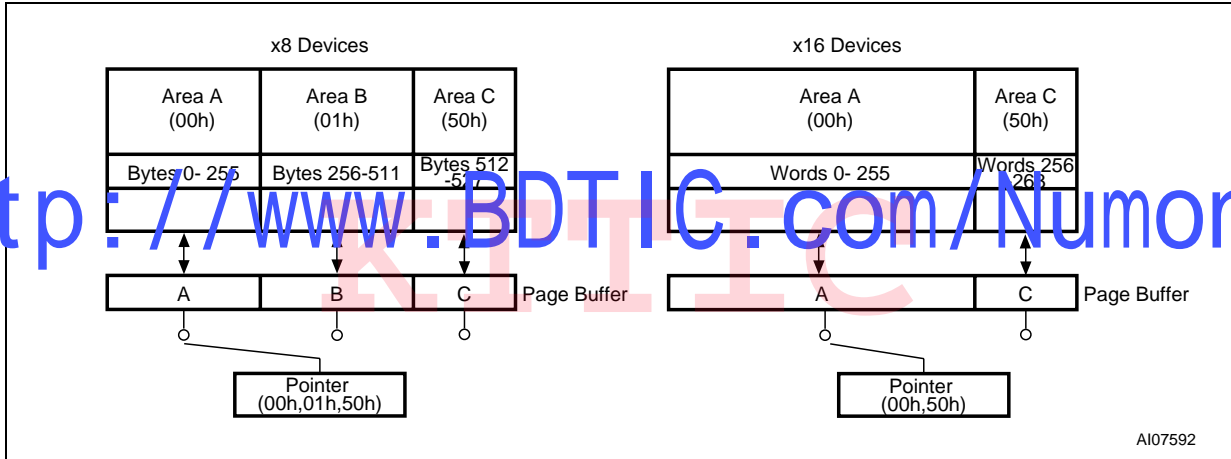
second half of the main area) that is Bytes 256 to 511.

In both the x8 and x16 devices the Read C command (50h), acts as a pointer to Area C (the spare memory area) that is Bytes 512 to 527 or Words 256 to 263.

Once the Read A and Read C commands have been issued the pointer remains in the respective areas until another pointer code is issued. However, the Read B command is effective for only one operation, once an operation has been executed in Area B the pointer returns automatically to Area A.

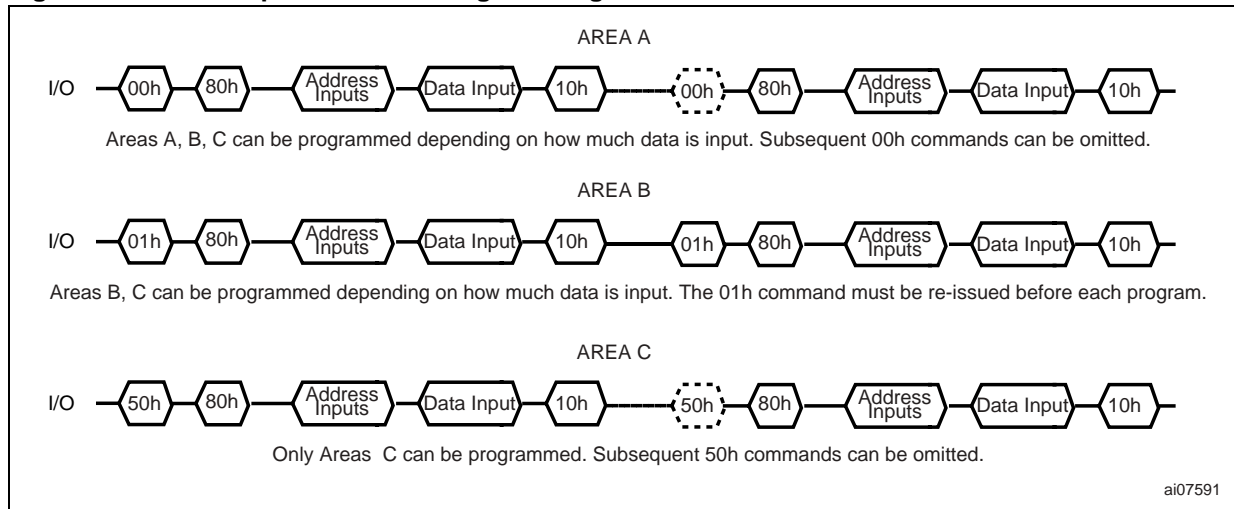
The pointer operations can also be used before a program operation, that is the appropriate code (00h, 01h or 50h) can be issued before the program command 80h is issued (see [Figure 12.](#)).

**Figure 11. Pointer Operations**



**NAND128-A, NAND256-A, NAND512-A, NAND01G-A**

**Figure 12. Pointer Operations for Programming**



<http://www.BDTIC.com/Numonyx>

**NAND128-A, NAND256-A, NAND512-A, NAND01G-A**

**Read Memory Array**

Each operation to read the memory area starts with a pointer operation as shown in the [Pointer Operations](#) section. Once the area (main or spare) has been selected using the Read A, Read B or Read C commands four bus cycles (for 512Mb and 1Gb devices) or three bus cycles (for 128Mb and 256Mb devices) are required to input the address (refer to [Table 6.](#)) of the data to be read.

The device defaults to Read A mode after power-up or a Reset operation.

When reading the spare area addresses:

- A0 to A3 (x8 devices)
- A0 to A2 (x16 devices)

are used to set the start address of the spare area while addresses:

- A4 to A7 (x8 devices)
- A3 to A7 (x16 devices)

are ignored.

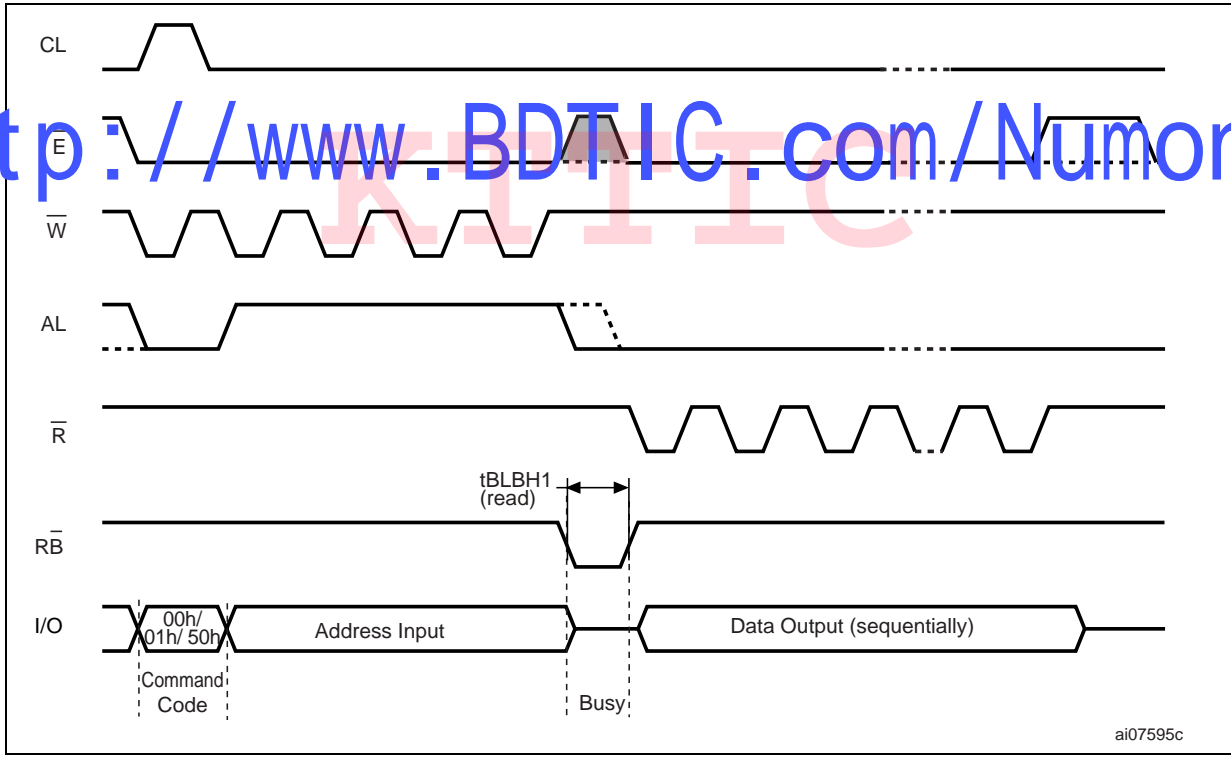
Once the Read A or Read C commands have been issued they do not need to be reissued for subsequent read operations as the pointer remains in the respective area. However, the Read B command is effective for only one operation, once an operation has been executed in Area B the pointer returns automatically to Area A and so another Read B command is required to start another read operation in Area B.

Once a read command is issued two types of operations are available: Random Read and Page Read.

**Random Read.** Each time the command is issued the first read is Random Read.

**Page Read.** After the Random Read access the page data is transferred to the Page Buffer in a time of  $t_{WHBH}$  (refer to [Table 21.](#) for value). Once the transfer is complete the Ready/Busy signal goes High. The data can then be read out sequentially (from selected column address to last column address) by pulsing the Read Enable signal.

**Figure 13. Read (A,B,C) Operations**

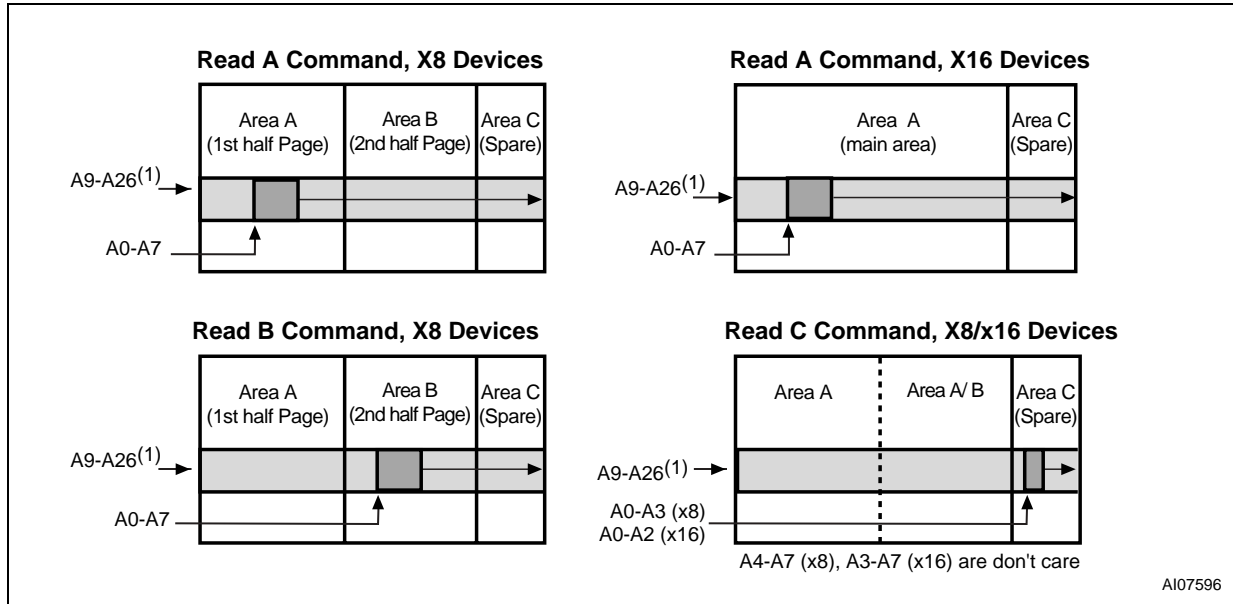


<http://www.BDTIC.com/Numonyx>



**NAND128-A, NAND256-A, NAND512-A, NAND01G-A**

**Figure 14. Read Block Diagrams**



Note: 1. Highest address depends on device density.

<http://www.BDTIC.com/Numonyx>

**NAND128-A, NAND256-A, NAND512-A, NAND01G-A**

**Page Program**

The Page Program operation is the standard operation to program data to the memory array.

The main area of the memory array is programmed by page, however partial page programming is allowed where any number of bytes (1 to 528) or words (1 to 264) can be programmed.

The maximum number of consecutive partial page program operations allowed in the same page is three. After exceeding this a Block Erase command must be issued before any further program operations can take place in that page.

Before starting a Page Program operation a Pointer operation can be performed to point to the area to be programmed. Refer to the [Pointer Operations](#) section and [Figure 12](#). for details.

Each Page Program operation consists of five steps (see [Figure 15](#)):

1. one bus cycle is required to setup the Page Program command
2. four bus cycles are then required to input the program address (refer to [Table 6](#).)

3. the data is then input (up to 528 Bytes/ 264 Words) and loaded into the Page Buffer
4. one bus cycle is required to issue the confirm command to start the P/E/R Controller.
5. The P/E/R Controller then programs the data into the array.

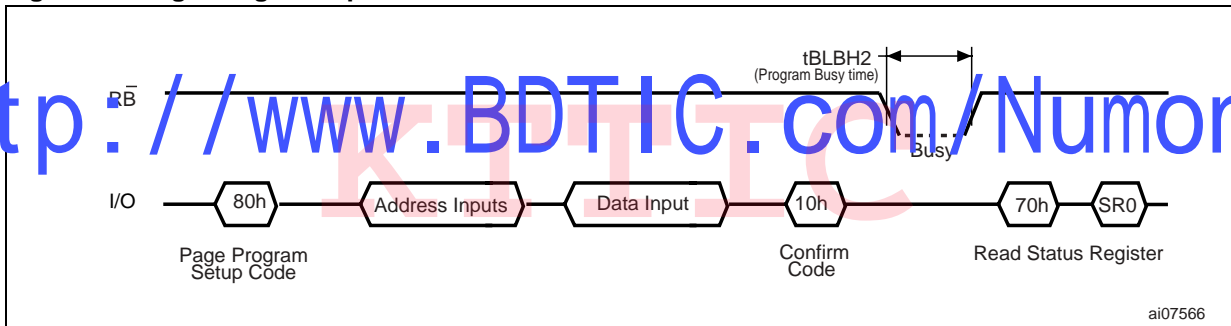
Once the program operation has started the Status Register can be read using the Read Status Register command. During program operations the Status Register will only flag errors for bits set to '1' that have not been successfully programmed to '0'.

During the program operation, only the Read Status Register and Reset commands will be accepted, all other commands will be ignored.

Once the program operation has completed the P/E/R Controller bit SR6 is set to '1' and the Ready/Busy signal goes High.

The device remains in Read Status Register mode until another valid command is written to the Command Interface.

**Figure 15. Page Program Operation**



Note: Before starting a Page Program operation a Pointer operation can be performed. Refer to [Pointer Operations](#) section for details.

<http://www.BDTIC.com/Numonyx>





**NAND128-A, NAND256-A, NAND512-A, NAND01G-A**

**Copy Back Program**

The Copy Back Program operation is used to copy the data stored in one page and reprogram it in another page.

The Copy Back Program operation does not require external memory and so the operation is faster and more efficient because the reading and loading cycles are not required. The operation is particularly useful when a portion of a block is updated and the rest of the block needs to be copied to the newly assigned block.

If the Copy Back Program operation fails an error is signalled in the Status Register. However as the standard external ECC cannot be used with the Copy Back operation bit error due to charge loss cannot be detected. For this reason it is recommended to limit the number of Copy Back operations on the same data and or to improve the performance of the ECC.

The Copy Back Program operation requires three steps:

1. The source page must be read using the Read A command (one bus write cycle to setup the command and then 4 bus write cycles to input the source page address). This operation copies all 264 Words/ 528 Bytes from the page into the Page Buffer.

2. When the device returns to the ready state (Ready/Busy High), the second bus write cycle of the command is given with the 4 bus cycles to input the target page address. Refer to Table 10. for the addresses that must be the same for the Source and Target pages.
3. Then the confirm command is issued to start the P/E/R Controller.

After a Copy Back Program operation, a partial-page program is not allowed in the target page until the block has been erased.

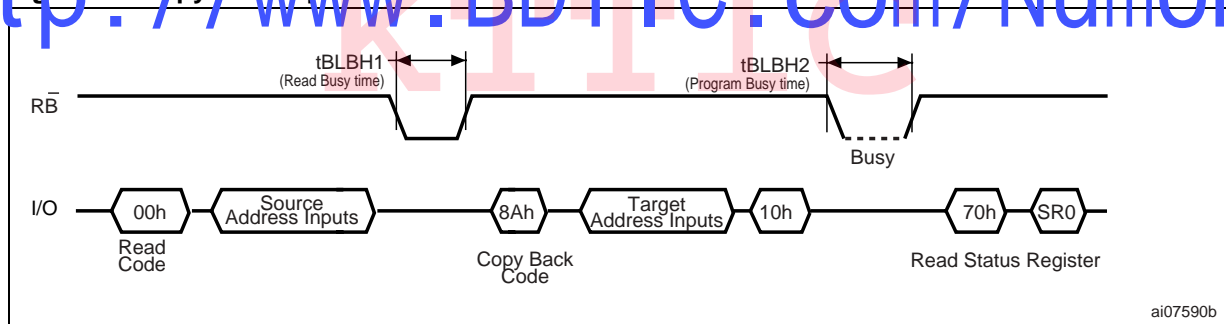
See Figure 16. for an example of the Copy Back operation.

**Table 10. Copy Back Program Addresses**

Density	Same Address for Source and Target Pages
128 Mbit	A23
256 Mbit	A24
512 Mbit	A14, A25
1 Gbit DD <sup>(1)</sup>	A14, A25, A26

Note: 1. DD = Dual Die.

Figure 16. Copy Back Operation



<http://www.BDTIC.com/Numonyx>

### NAND128-A, NAND256-A, NAND512-A, NAND01G-A

#### Block Erase

Erase operations are done one block at a time. An erase operation sets all of the bits in the addressed block to '1'. All previous data in the block is lost.

An erase operation consists of three steps (refer to Figure 17.):

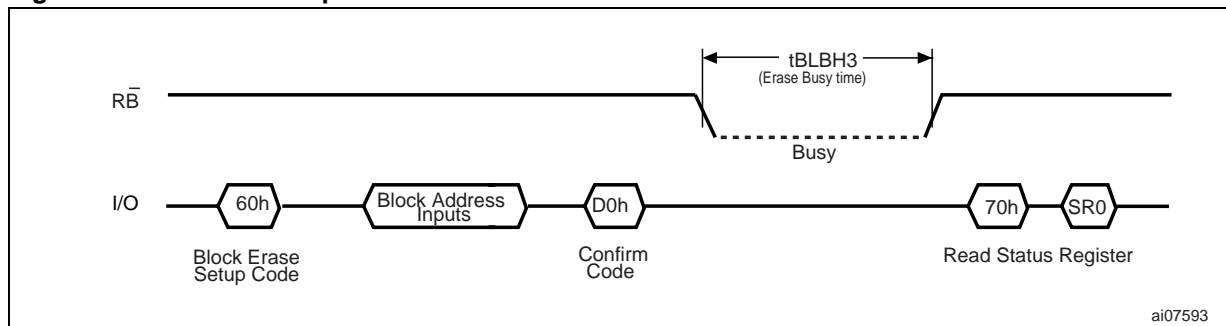
1. One bus cycle is required to setup the Block Erase command.
2. Only three bus cycles for 512Mb and 1Gb devices, or two for 128Mb and 256Mb devices

are required to input the block address. The first cycle (A0 to A7) is not required as only addresses A14 to A26 (highest address depends on device density) are valid, A9 to A13 are ignored. In the last address cycle I/O2 to I/O7 must be set to V<sub>IL</sub>.

3. One bus cycle is required to issue the confirm command to start the P/E/R Controller.

Once the erase operation has completed the Status Register can be checked for errors.

Figure 17. Block Erase Operation



#### Reset

The Reset command is used to reset the Command Interface and Status Register. If the Reset command is issued during any operation, the operation will be aborted. If it was a program or erase operation that was aborted, the contents of the memory locations being modified will no longer be valid as the data will be partially programmed or erased.

If the device has already been reset then the new Reset command will not be accepted.

The Ready/Busy signal goes Low for  $t_{BLBH4}$  after the Reset command is issued. The value of  $t_{BLBH4}$  depends on the operation that the device was performing when the command was issued, refer to Table 21. for the values.

<http://www.BDTIC.com/Numonyx>



---

**NAND128-A, NAND256-A, NAND512-A, NAND01G-A**

---

**Read Status Register**

The device contains a Status Register which provides information on the current or previous Program or Erase operation. The various bits in the Status Register convey information and errors on the operation.

The Status Register is read by issuing the Read Status Register command. The Status Register information is present on the output data bus (I/O0-I/O7) on the falling edge of Chip Enable or Read Enable, whichever occurs last. When several memories are connected in a system, the use of Chip Enable and Read Enable signals allows the system to poll each device separately, even when the Ready/Busy pins are common-wired. It is not necessary to toggle the Chip Enable or Read Enable signals to update the contents of the Status Register.

After the Read Status Register command has been issued, the device remains in Read Status Register mode until another command is issued. Therefore if a Read Status Register command is issued during a Random Read cycle a new read command must be issued to continue with a Page Read.

The Status Register bits are summarized in [Table 11., Status Register Bits](#). Refer to [Table 11.](#) in conjunction with the following text descriptions.

**Write Protection Bit (SR7).** The Write Protection bit can be used to identify if the device is protected or not. If the Write Protection bit is set to '1' the device is not protected and program or erase operations are allowed. If the Write Protection bit is set to '0' the device is protected and program or erase operations are not allowed.

**P/E/R Controller Bit (SR6).** The Program/Erase/Read Controller bit indicates whether the P/E/R Controller is active or inactive. When the P/E/R Controller bit is set to '0', the P/E/R Controller is active (device is busy); when the bit is set to '1', the P/E/R Controller is inactive (device is ready).

**Error Bit (SR0).** The Error bit is used to identify if any errors have been detected by the P/E/R Controller. The Error Bit is set to '1' when a program or erase operation has failed to write the correct data to the memory. If the Error Bit is set to '0' the operation has completed successfully.

**SR5, SR4, SR3, SR2 and SR1 are Reserved.**

<http://www.BDTIC.com/Numonyx>

**NAND128-A, NAND256-A, NAND512-A, NAND01G-A**

**Table 11. Status Register Bits**

Bit	Name	Logic Level	Definition
SR7	Write Protection	'1'	Not Protected
		'0'	Protected
SR6	Program/ Erase/ Read Controller	'1'	P/E/R C inactive, device ready
		'0'	P/E/R C active, device busy
SR5, SR4, SR3, SR2, SR1	Reserved	Don't Care	
SR0	Generic Error	'1'	Error – operation failed
		'0'	No Error – operation successful

**Read Electronic Signature**

The device contains a Manufacturer Code and Device Code. To read these codes two steps are required:

1. first use one Bus Write cycle to issue the Read Electronic Signature command (90h), followed by an address input of 00h.
2. then perform two Bus Read operations – the first will read the Manufacturer Code and the second, the Device Code. Further Bus Read operations will be ignored.

Refer to [Table 12., Electronic Signature](#), for information on the addresses.

**Table 12. Electronic Signature**

Part Number	Manufacturer Code	Device code
NAND128W3A	20h	73h
NAND256R3A	20h	35h
NAND256W3A		75h
NAND256R4A	0020h	0045h
NAND256W4A		0055h
NAND512R3A	20h	36h
NAND512W3A		76h
NAND512R4A	0020h	0046h
NAND512W4A		0056h
NAND01GR3A	20h	39h
NAND01GW3A		79h
NAND01GR4A	0020h	0049h
NAND01GW4A		0059h

<http://www.BDTIC.com/Numonyx>



## SOFTWARE ALGORITHMS

This section gives information on the software algorithms that ST recommends to implement to manage the Bad Blocks and extend the lifetime of the NAND device.

NAND Flash memories are programmed and erased by Fowler-Nordheim tunneling using a high voltage. Exposing the device to a high voltage for extended periods can cause the oxide layer to be damaged. For this reason, the number of program and erase cycles is limited (see Table 14. for value) and it is recommended to implement Garbage Collection, a Wear-Leveling Algorithm and an Error Correction Code, to extend the number of program and erase cycles and increase the data retention.

To help integrate a NAND memory into an application ST Microelectronics can provide:

- File System OS Native reference software, which supports the basic commands of file management.

Contact the nearest ST Microelectronics sales office for more details.

### Bad Block Management

Devices with Bad Blocks have the same quality level and the same AC and DC characteristics as devices where all the blocks are valid. A Bad Block does not affect the performance of valid blocks because it is isolated from the bit line and common source line by a select transistor.

The devices are supplied with all the locations inside valid blocks erased (FFh). The Bad Block Information is written prior to shipping. Any block where the 6th byte (x8 device) / 1st word (x16 device) in the spare area of the 1st page does not contain FFh is a Bad Block.

The Bad Block Information must be read before any erase is attempted as the Bad Block Information may be erased. For the system to be able to recognize the Bad Blocks based on the original information it is recommended to create a Bad Block table following the flowchart shown in Figure 18.

### Block Replacement

Over the lifetime of the device additional Bad Blocks may develop. In this case the block has to be replaced by copying the data to a valid block. These additional Bad Blocks can be identified as

attempts to program or erase them will give errors in the Status Register.

As the failure of a page program operation does not affect the data in other pages in the same block, the block can be replaced by re-programming the current data and copying the rest of the replaced block to an available valid block. The Copy Back Program command can be used to copy the data to a valid block.

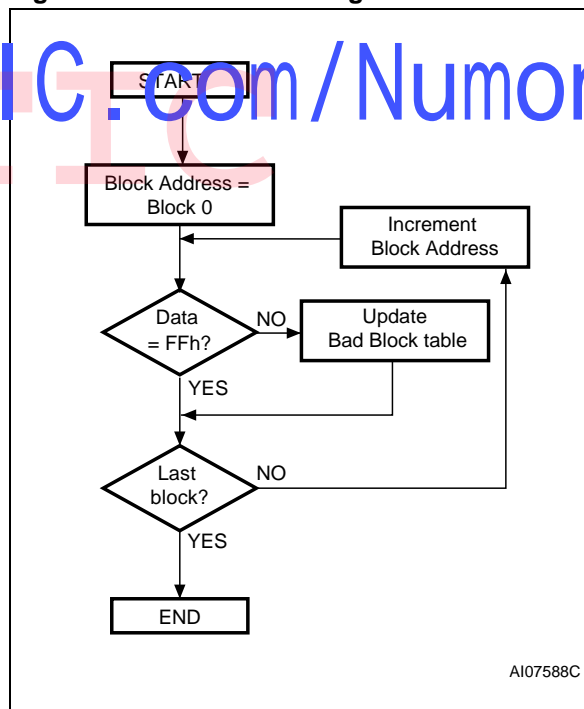
See the "Copy Back Program" section for more details.

Refer to Table 13. for the recommended procedure to follow if an error occurs during an operation.

Table 13. Block Failure

Operation	Recommended Procedure
Erase	Block Replacement
Program	Block Replacement or ECC
Read	ECC

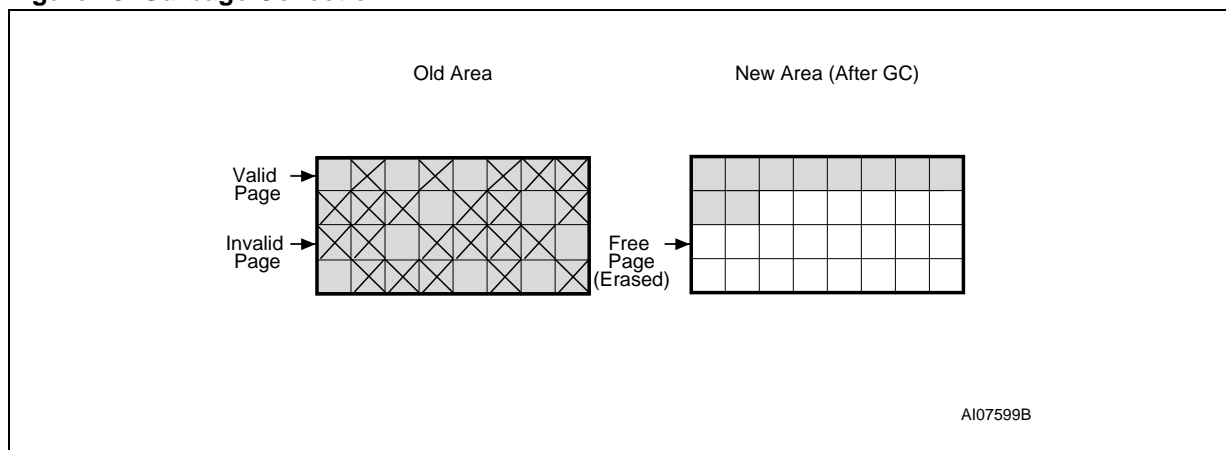
Figure 18. Bad Block Management Flowchart



AI07588C

**NAND128-A, NAND256-A, NAND512-A, NAND01G-A**

**Figure 19. Garbage Collection**



**Garbage Collection**

When a data page needs to be modified, it is faster to write to the first available page, and the previous page is marked as invalid. After several updates it is necessary to remove invalid pages to free some memory space.

To free this memory space and allow further program operations it is recommended to implement a Garbage Collection algorithm. In a Garbage Collection software the valid pages are copied into a free area and the block containing the invalid pages is erased (see Figure 9).

**Wear-leveling Algorithm**

For write-intensive applications, it is recommended to implement a Wear-leveling Algorithm to monitor and spread the number of write cycles per block.

In memories that do not use a Wear-Leveling Algorithm not all blocks get used at the same rate. Blocks with long-lived data do not endure as many write cycles as the blocks with frequently-changed data.

The Wear-leveling Algorithm ensures that equal use is made of all the available write cycles for each block. There are two wear-leveling levels:

- First Level Wear-leveling, new data is programmed to the free blocks that have had the fewest write cycles
- Second Level Wear-leveling, long-lived data is copied to another block so that the original block can be used for more frequently-changed data.

The Second Level Wear-leveling is triggered when the difference between the maximum and the minimum number of write cycles per block reaches a specific threshold.

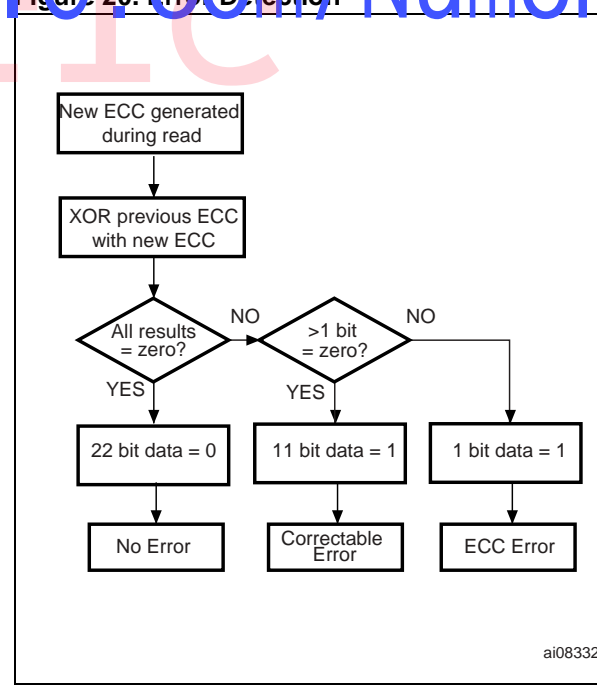
**Error Correction Code**

An Error Correction Code (ECC) can be implemented in the Nand Flash memories to identify and correct errors in the data.

For every 2048 bits in the device it is recommended to implement 22 bits of ECC (16 bits for line parity plus 6 bits for column parity).

An ECC model is available in VHDL or Verilog. Contact the nearest ST Microelectronics sales office for more details.

**Figure 20. Error Detection**



<http://www.BDTIC.com/Numonyx>



---

**NAND128-A, NAND256-A, NAND512-A, NAND01G-A**

---

**Hardware Simulation Models**

**Behavioral simulation models.** Denali Software Corporation models are platform independent functional models designed to assist customers in performing entire system simulations (typical VHDL/Verilog). These models describe the logic behavior and timings of NAND Flash devices, and so allow software to be developed before hardware.

**IBIS simulations models.** IBIS (I/O Buffer Information Specification) models describe the behav-

ior of the I/O buffers and electrical characteristics of Flash devices.

These models provide information such as AC characteristics, rise/fall times and package mechanical data, all of which are measured or simulated at voltage and temperature ranges wider than those allowed by target specifications.

IBIS models are used to simulate PCB connections and can be used to resolve compatibility issues when upgrading devices. They can be imported into SPICETOOLS.

<http://www.BDTIC.com/Numonyx>

**NAND128-A, NAND256-A, NAND512-A, NAND01G-A**

**PROGRAM AND ERASE TIMES AND ENDURANCE CYCLES**

The Program and Erase times and the number of Program/ Erase cycles per block are shown in [Table 14](#).

**Table 14. Program, Erase Times and Program Erase Endurance Cycles**

Parameters	NAND Flash			Unit
	Min	Typ	Max	
Page Program Time		200	500	μs
Block Erase Time		2	3	ms
Program/Erase Cycles (per block)	100,000			cycles
Data Retention	10			years

**MAXIMUM RATING**

Stressing the device above the ratings listed in [Table 15](#), [Absolute Maximum Ratings](#), may cause permanent damage to the device. These are stress ratings only and operation of the device at these or any other conditions above those indicated in the Operating sections of this specification is

not implied. Exposure to Absolute Maximum Rating conditions for extended periods may affect device reliability. Refer also to the STMicroelectronics SURE Program and other relevant quality documents.

**Table 15. Absolute Maximum Ratings**

Symbol	Parameter	Value		Unit	
		Min	Max		
T <sub>BIAS</sub>	Temperature Under Bias	- 50	125	°C	
T <sub>STG</sub>	Storage Temperature	- 65	150	°C	
T <sub>LEAD</sub>	Lead temperature during soldering <sup>(2)</sup>		260	°C	
V <sub>IO</sub> <sup>(1)</sup>	Input or Output Voltage	1.8V devices	- 0.6	2.7	V
		3 V devices	- 0.6	4.6	V
V <sub>DD</sub>	Supply Voltage	1.8V devices	- 0.6	2.7	V
		3 V devices	- 0.6	4.6	V

Note: 1. Minimum Voltage may undershoot to -2V for less than 20ns during transitions on input and I/O pins. Maximum voltage may overshoot to V<sub>DD</sub> + 2V for less than 20ns during transitions on I/O pins.  
 2. Compatibility with Lead-free soldering processes in accordance with ECOPACK 7191395 specifications. Not exceeding 250°C for more than 10s, and peaking at 260°C.





**NAND128-A, NAND256-A, NAND512-A, NAND01G-A**

**DC AND AC PARAMETERS**

This section summarizes the operating and measurement conditions, and the DC and AC characteristics of the device. The parameters in the DC and AC characteristics Tables that follow, are derived from tests performed under the Measure-

ment Conditions summarized in [Table 16., Operating and AC Measurement Conditions](#). Designers should check that the operating conditions in their circuit match the measurement conditions when relying on the quoted parameters.

**Table 16. Operating and AC Measurement Conditions**

Parameter		NAND Flash		Units
		Min	Max	
Supply Voltage (V <sub>DD</sub> )	1.8V devices	1.7	1.95	V
	3V devices	2.7	3.6	V
Ambient Temperature (T <sub>A</sub> )	Grade 6	-40	85	°C
Load Capacitance (C <sub>L</sub> ) (1 TTL GATE and C <sub>L</sub> )	1.8V devices	30		pF
	3V devices (2.7 - 3.6V)	50		pF
	3V devices (3.0 - 3.6V)	100		pF
Input Pulses Voltages	1.8V devices	0	V <sub>DD</sub>	V
	3V devices	0.4	2.4	V
Input and Output Timing Ref. Voltages	1.8V devices	0.9		V
	3V devices	1.5		V
Input Rise and Fall Times		5		ns
Output Circuit Resistors (R <sub>re</sub> )		3.35		kΩ

**Table 17. Capacitance**

Symbol	Parameter	Test Condition	Typ	Max	Unit
C <sub>IN</sub>	Input Capacitance	V <sub>IN</sub> = 0V		10	pF
C <sub>I/O</sub>	Input/Output Capacitance	V <sub>IL</sub> = 0V		10	pF

Note: T<sub>A</sub> = 25°C, f = 1 MHz. C<sub>IN</sub> and C<sub>I/O</sub> are not 100% tested.  
 Note: Input/Output capacitances double on stacked devices

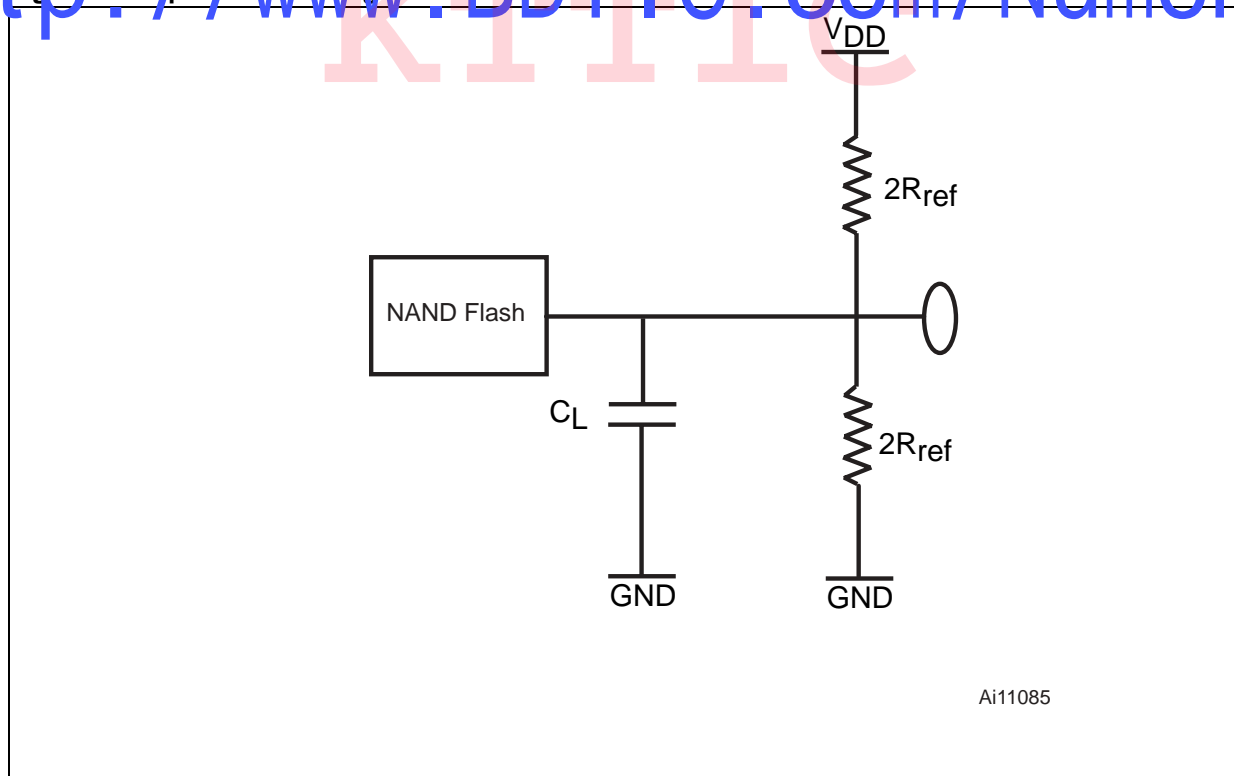
**NAND128-A, NAND256-A, NAND512-A, NAND01G-A**

**Table 18. DC Characteristics, 1.8V Devices**

Symbol	Parameter	Test Conditions	Min	Typ	Max	Unit
$I_{DD1}$	Operating Current	Sequential Read $\bar{E}=V_{IL}, I_{OUT} = 0 \text{ mA}$	-	8	15	mA
$I_{DD2}$		Program	-	8	15	mA
$I_{DD3}$		Erase	-	-	8	15
$I_{DD5}$	Stand-By Current (CMOS) 128Mb, 256Mb, 512Mb devices	$\bar{E}=V_{DD}-0.2,$ $WP=0/V_{DD}$	-	10	50	$\mu\text{A}$
	Stand-By Current (CMOS) 512Mb and 1Gb Dual Die devices		-	20	100	$\mu\text{A}$
$I_{LI}$	Input Leakage Current	$V_{IN} = 0 \text{ to } V_{DDmax}$	-	-	$\pm 10$	$\mu\text{A}$
$I_{LO}$	Output Leakage Current	$V_{OUT} = 0 \text{ to } V_{DDmax}$	-	-	$\pm 10$	$\mu\text{A}$
$V_{IH}$	Input High Voltage	-	$V_{DD}-0.4$	-	$V_{DD}+0.3$	V
$V_{IL}$	Input Low Voltage	-	-0.3	-	0.4	V
$V_{OH}$	Output High Voltage Level	$I_{OH} = -100\mu\text{A}$	$V_{DD}-0.1$	-	-	V
$V_{OL}$	Output Low Voltage Level	$I_{OL} = 100\mu\text{A}$	-	-	0.1	V
$I_{OL} (\bar{R}\bar{B})$	Output Low Current ( $\bar{R}\bar{B}$ )	$V_{OL} = 0.1\text{V}$	3	4		mA
$V_{LKO}$	$V_{DD}$ Supply Voltage (Erase and Program lockout)	-	-	-	1.1	V

Note: Leakage currents double on stacked devices.

**Figure 21. Equivalent Testing Circuit For AC Characteristics Measurement**



**NAND128-A, NAND256-A, NAND512-A, NAND01G-A**

**Table 19. DC Characteristics, 3V Devices**

Symbol	Parameter	Test Conditions	Min	Typ	Max	Unit
I <sub>DD1</sub>	Operating Current	Sequential Read $t_{RLRL}$ minimum $\bar{E}=V_{IL}, I_{OUT} = 0 \text{ mA}$	-	10	20	mA
I <sub>DD2</sub>		Program	-	10	20	mA
I <sub>DD3</sub>		Erase	-	-	10	20
I <sub>DD4</sub>	Stand-by Current (TTL), 128Mb, 256Mb, 512Mb devices	$\bar{E}=V_{IH}, \overline{WP}=0V/V_{DD}$	-	-	1	mA
	Stand-by Current (TTL) 512Mb and 1Gb Dual Die devices		-	-	2	mA
I <sub>DD5</sub>	Stand-By Current (CMOS) 128Mb, 256Mb, 512Mb devices	$\bar{E}=V_{DD}-0.2,$ $\overline{WP}=0/V_{DD}$	-	10	50	μA
	Stand-By Current (CMOS) 512Mb and 1Gb Dual Die devices		-	20	100	μA
I <sub>LI</sub>	Input Leakage Current	$V_{IN} = 0 \text{ to } V_{DDmax}$	-	-	±10	μA
I <sub>LO</sub>	Output Leakage Current	$V_{OUT} = 0 \text{ to } V_{DDmax}$	-	-	±10	μA
V <sub>IH</sub>	Input High Voltage	-	2.0	-	V <sub>DD</sub> +0.3	V
V <sub>IL</sub>	Input Low Voltage	-	-0.3	-	0.8	V
V <sub>OH</sub>	Output High Voltage Level	I <sub>OH</sub> = -400μA	2.4	-	-	V
V <sub>OL</sub>	Output Low Voltage Level	I <sub>OL</sub> = 2.1mA	-	-	0.4	V
I <sub>OL</sub> (R $\bar{B}$ )	Output Low Current (R $\bar{B}$ )	V <sub>OL</sub> = 0.4V	8	10	-	mA
V <sub>ER0</sub>	V <sub>DD</sub> Supply Voltage (Erase and Program lockout)	-	-	-	1.7	V

Note: Leakage currents double on stacked devices.

<http://www.BDTIC.com/Numonyx>

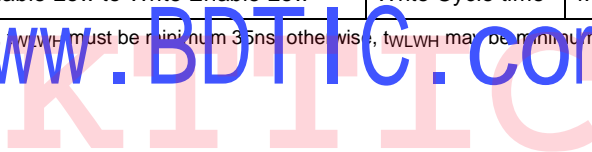
**NAND128-A, NAND256-A, NAND512-A, NAND01G-A**

**Table 20. AC Characteristics for Command, Address, Data Input**

Symbol	Alt. Symbol	Parameter			1.8V Devices	3V Devices	Unit
t <sub>ALLWL</sub>	t <sub>ALS</sub>	Address Latch Low to Write Enable Low	AL Setup time	Min	0	0	ns
t <sub>ALHWL</sub>		Address Latch High to Write Enable Low					
t <sub>CLHWL</sub>	t <sub>CLS</sub>	Command Latch High to Write Enable Low	CL Setup time	Min	0	0	ns
t <sub>CLLWL</sub>		Command Latch Low to Write Enable Low					
t <sub>DVWH</sub>	t <sub>DS</sub>	Data Valid to Write Enable High	Data Setup time	Min	20	20	ns
t <sub>ELWL</sub>	t <sub>CS</sub>	Chip Enable Low to Write Enable Low	$\bar{E}$ Setup time	Min	0	0	ns
t <sub>WHALH</sub>	t <sub>ALH</sub>	Write Enable High to Address Latch High	AL Hold time	Min	10	10	ns
t <sub>WHALL</sub>		Write Enable High to Address Latch Low					
t <sub>WHCLH</sub>	t <sub>CLH</sub>	Write Enable High to Command Latch High	CL hold time	Min	10	10	ns
t <sub>WHCLL</sub>		Write Enable High to Command Latch Low					
t <sub>WHDX</sub>	t <sub>DH</sub>	Write Enable High to Data Transition	Data Hold time	Min	10	10	ns
t <sub>WHEH</sub>	t <sub>CH</sub>	Write Enable High to Chip Enable High	$\bar{E}$ Hold time	Min	10	10	ns
t <sub>WHWL</sub>	t <sub>WH</sub>	Write Enable High to Write Enable Low	$\bar{W}$ High Hold time	Min	20	15	ns
t <sub>WLWH</sub>	t <sub>WP</sub>	Write Enable Low to Write Enable High	$\bar{W}$ Pulse Width	Min	40	25 <sup>(1)</sup>	ns
t <sub>WLWL</sub>	t <sub>WC</sub>	Write Enable Low to Write Enable Low	Write Cycle time	Min	60	50	ns

Note 1: If t<sub>ELWL</sub> is less than 10 ns, t<sub>WHWL</sub> must be minimum 35 ns; otherwise, t<sub>WLWH</sub> may be minimum 25 ns.

<http://www.BDTIC.com/Numonyx>



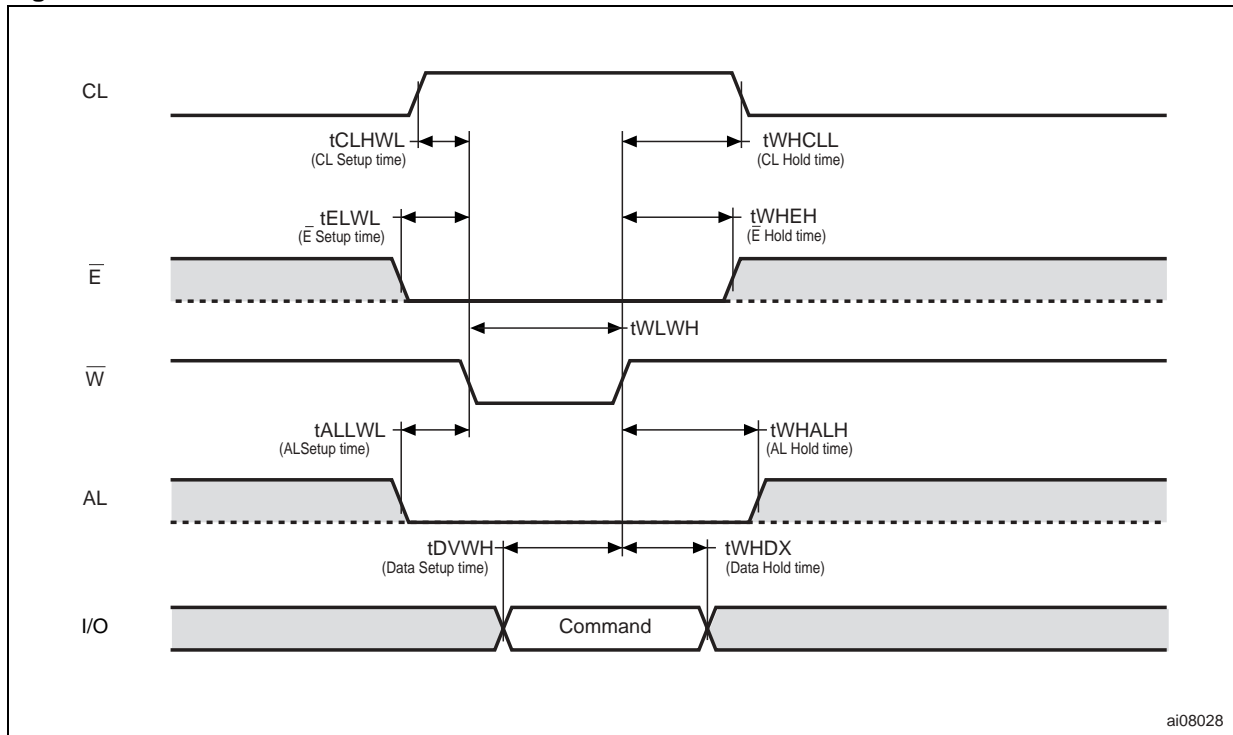
**NAND128-A, NAND256-A, NAND512-A, NAND01G-A****Table 21. AC Characteristics for Operations**

Symbol	Alt. Symbol	Parameter			1.8V Devices	3V Devices	Unit	
t <sub>ALLRL1</sub>	t <sub>AR</sub>	Address Latch Low to Read Enable Low	Read Electronic Signature	Min	10	10	ns	
t <sub>ALLRL2</sub>			Read cycle	Min	10	10	ns	
t <sub>BHRL</sub>	t <sub>RR</sub>	Ready/Busy High to Read Enable Low			Min	20	20	ns
t <sub>BLBH1</sub>	t <sub>PROG</sub>	Ready/Busy Low to Ready/Busy High	Read Busy time, 128Mb, 256Mb, 512Mb Dual Die	Max	12	12	μs	
			Read Busy time, 512Mb, 1Gb	Max	15	12	μs	
Program Busy time			Max	500	500	μs		
Erased Busy time			Max	3	3	ms		
Reset Busy time, during ready			Max	5	5	μs		
t <sub>BLBH2</sub>	t <sub>BERS</sub>	Write Enable High to Ready/Busy High	Reset Busy time, during read	Max	5	5	μs	
t <sub>BLBH3</sub>			Reset Busy time, during program	Max	10	10	μs	
t <sub>BLBH4</sub>			Reset Busy time, during erase	Max	500	500	μs	
t <sub>CLLRL</sub>	t <sub>CLR</sub>	Command Latch Low to Read Enable Low			Min	10	10	ns
t <sub>DZRL</sub>	t <sub>IR</sub>	Data Hi-Z to Read Enable Low			Min	0	0	ns
t <sub>EHQZ</sub>	t <sub>CHZ</sub>	Chip Enable High to Output Hi-Z			Max	20	20	ns
t <sub>ELQV</sub>	t <sub>CEA</sub>	Chip Enable Low to Output Valid			Max	45	45	ns
t <sub>RHRL</sub>	t <sub>REH</sub>	Read Enable High to Read Enable Low	Read Enable High Hold time	Min	15	15	ns	
t <sub>PHQZ</sub>	t <sub>PHZ</sub>	Read Enable High to Output Hi-Z			Max	30	30	ns
t <sub>THQX</sub>	t <sub>OH</sub>	Chip Enable high or Read Enable high to Output Hold			Min	10	10	ns
t <sub>TRHGX</sub>								
t <sub>RLRH</sub>	t <sub>RP</sub>	Read Enable Low to Read Enable High	Read Enable Pulse Width	Min	30	25	ns	
t <sub>RLRL</sub>	t <sub>RC</sub>	Read Enable Low to Read Enable Low	Read Cycle time	Min	60	50	ns	
t <sub>RLQV</sub>	t <sub>REA</sub>	Read Enable Low to Output Valid	Read Enable Access time	Max	35	35	ns	
			Read ES Access time <sup>(1)</sup>					
t <sub>WHBH</sub>	t <sub>R</sub>	Write Enable High to Ready/Busy High	Read Busy time, 128Mb, 256Mb, 512Mb Dual Die	Max	12	12	μs	
			Read Busy time, 512Mb, 1Gb	Max	15	12	μs	
t <sub>WHBL</sub>	t <sub>WB</sub>	Write Enable High to Ready/Busy Low			Max	100	100	ns
t <sub>WHRL</sub>	t <sub>WHR</sub>	Write Enable High to Read Enable Low			Min	80	60	ns
t <sub>WLWL</sub>	t <sub>WC</sub>	Write Enable Low to Write Enable Low	Write Cycle time	Min	60	50	ns	

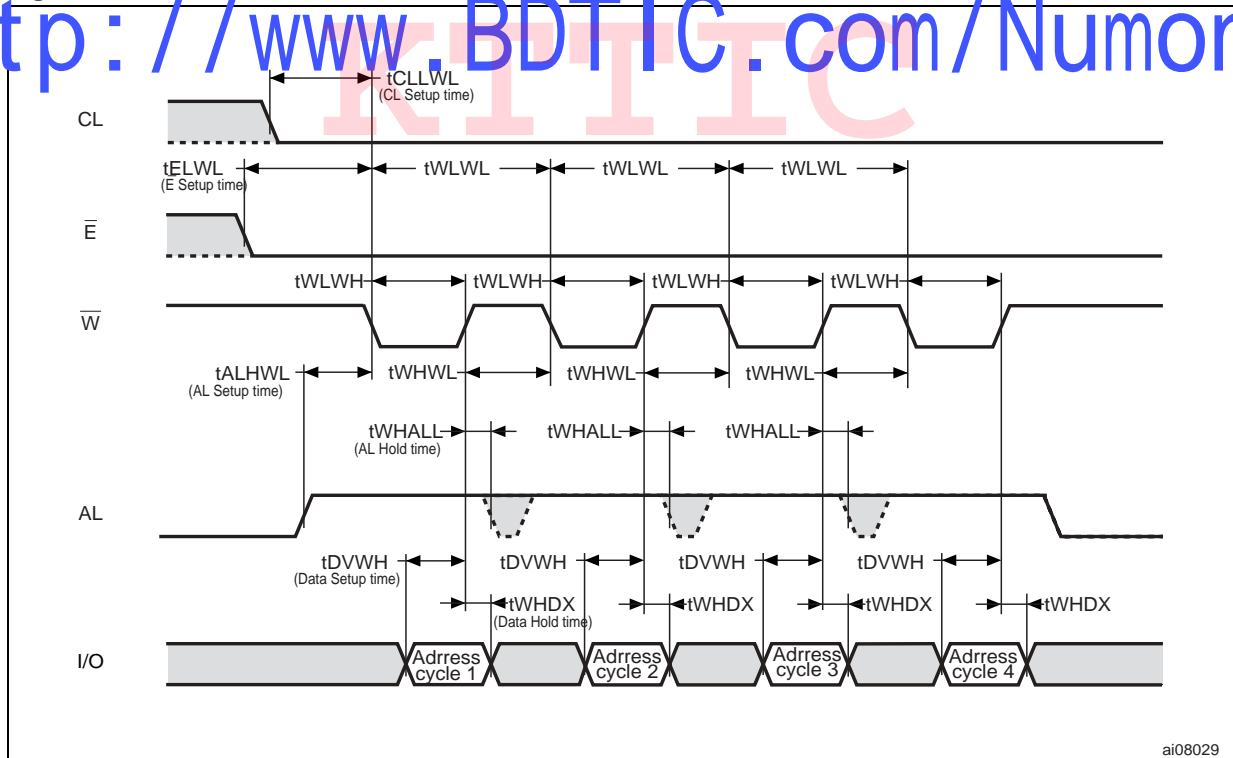
Note: 1. ES = Electronic Signature.

**NAND128-A, NAND256-A, NAND512-A, NAND01G-A**

**Figure 22. Command Latch AC Waveforms**



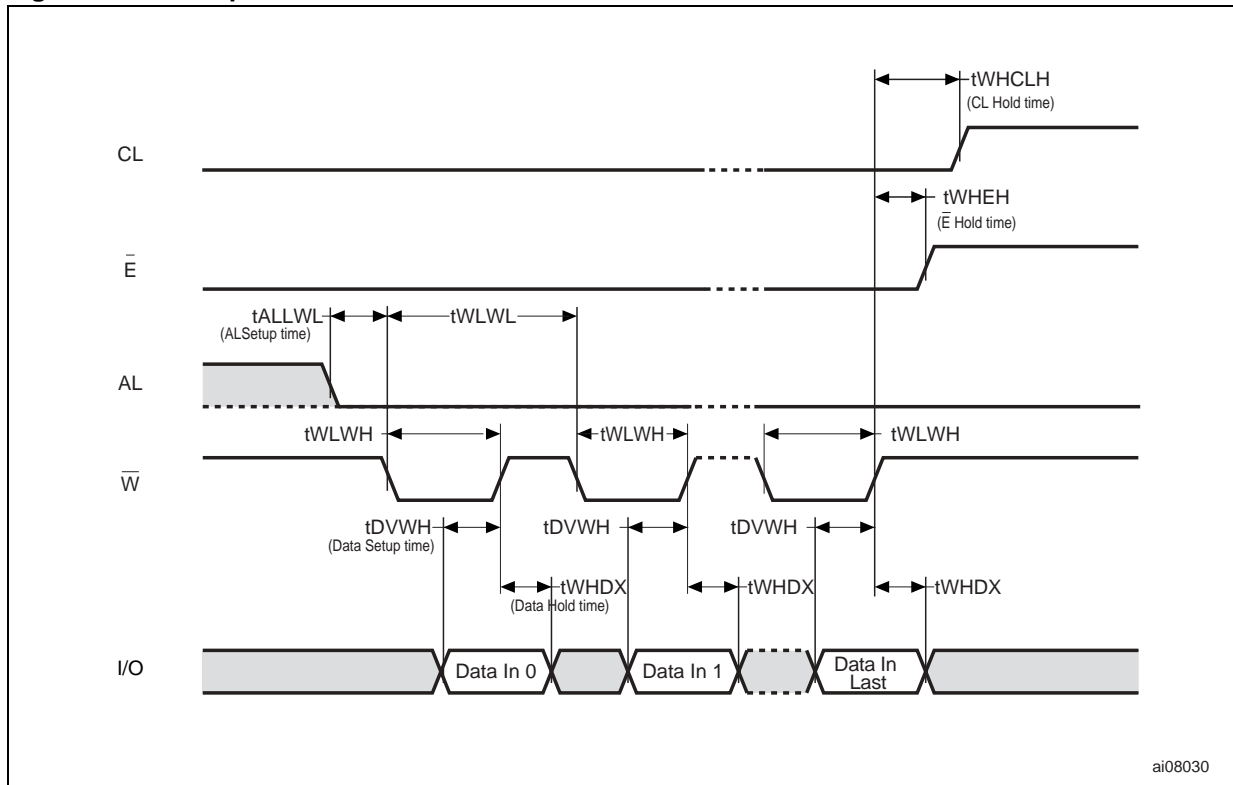
**Figure 23. Address Latch AC Waveforms**



Note: Address cycle 4 is only required for 512Mb and 1Gb devices.

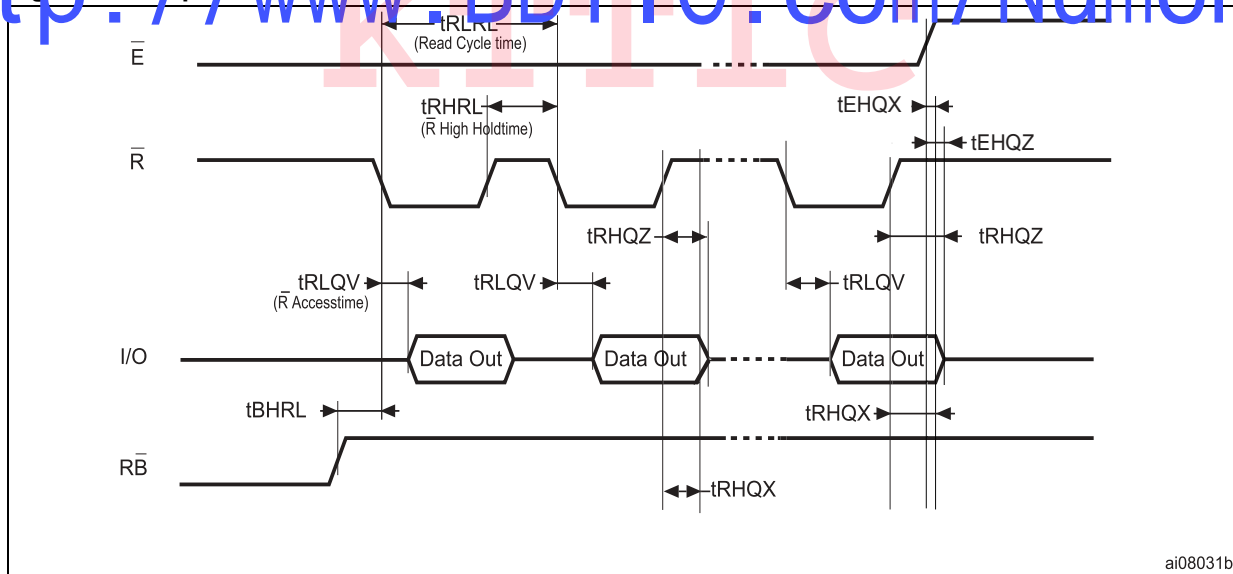
NAND128-A, NAND256-A, NAND512-A, NAND01G-A

Figure 24. Data Input Latch AC Waveforms



ai08030

Figure 25. Sequential Data Output after Read AC Waveforms

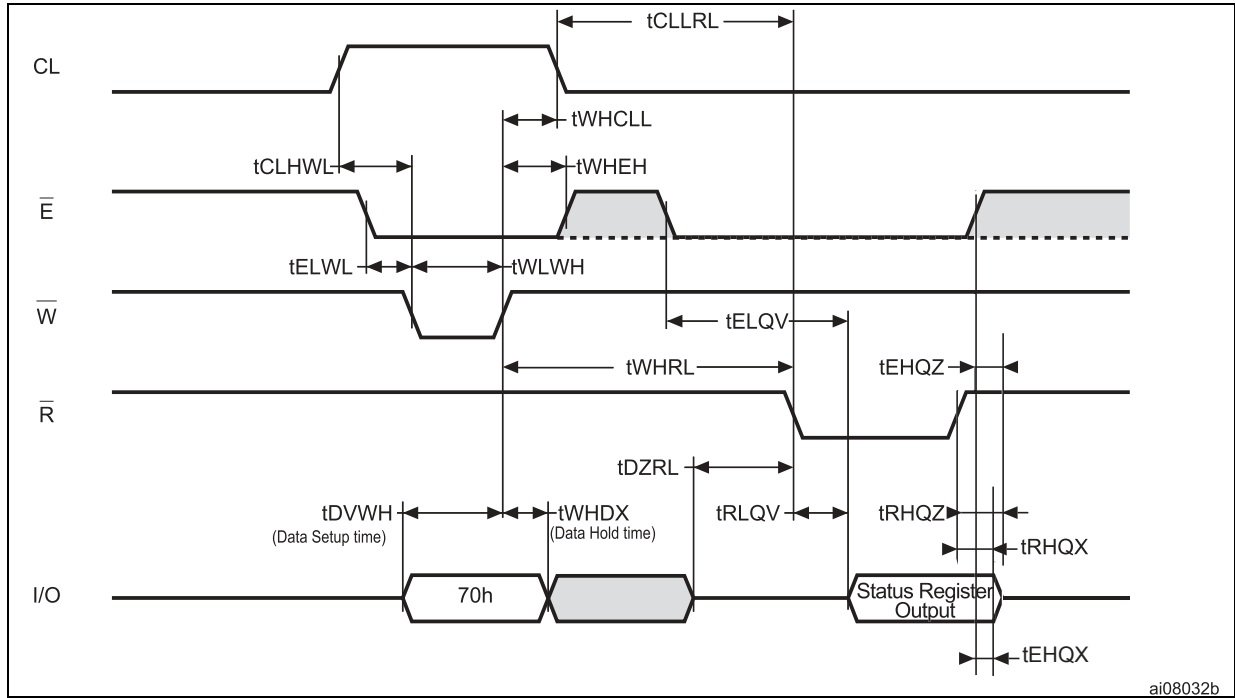


ai08031b

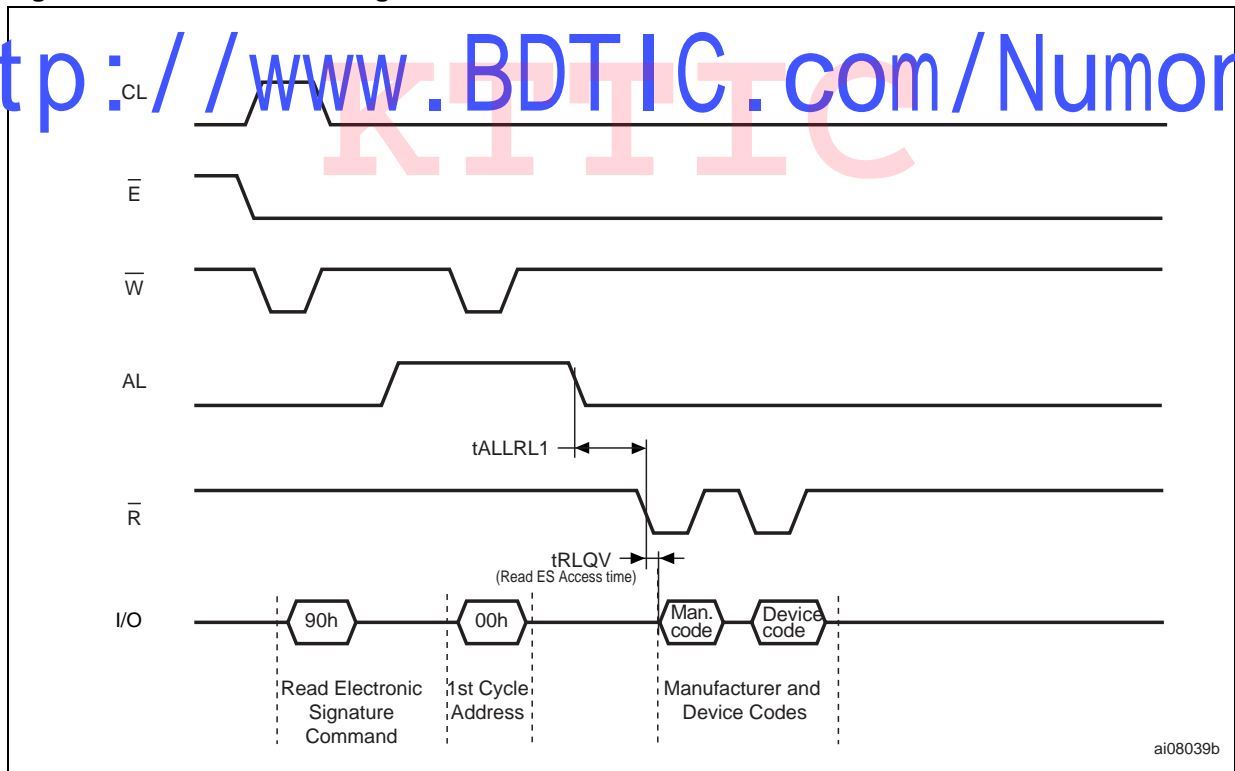
Note: 1. CL = Low, AL = Low, W-bar = High.

**NAND128-A, NAND256-A, NAND512-A, NAND01G-A**

**Figure 26. Read Status Register AC Waveform**



**Figure 27. Read Electronic Signature AC Waveform**



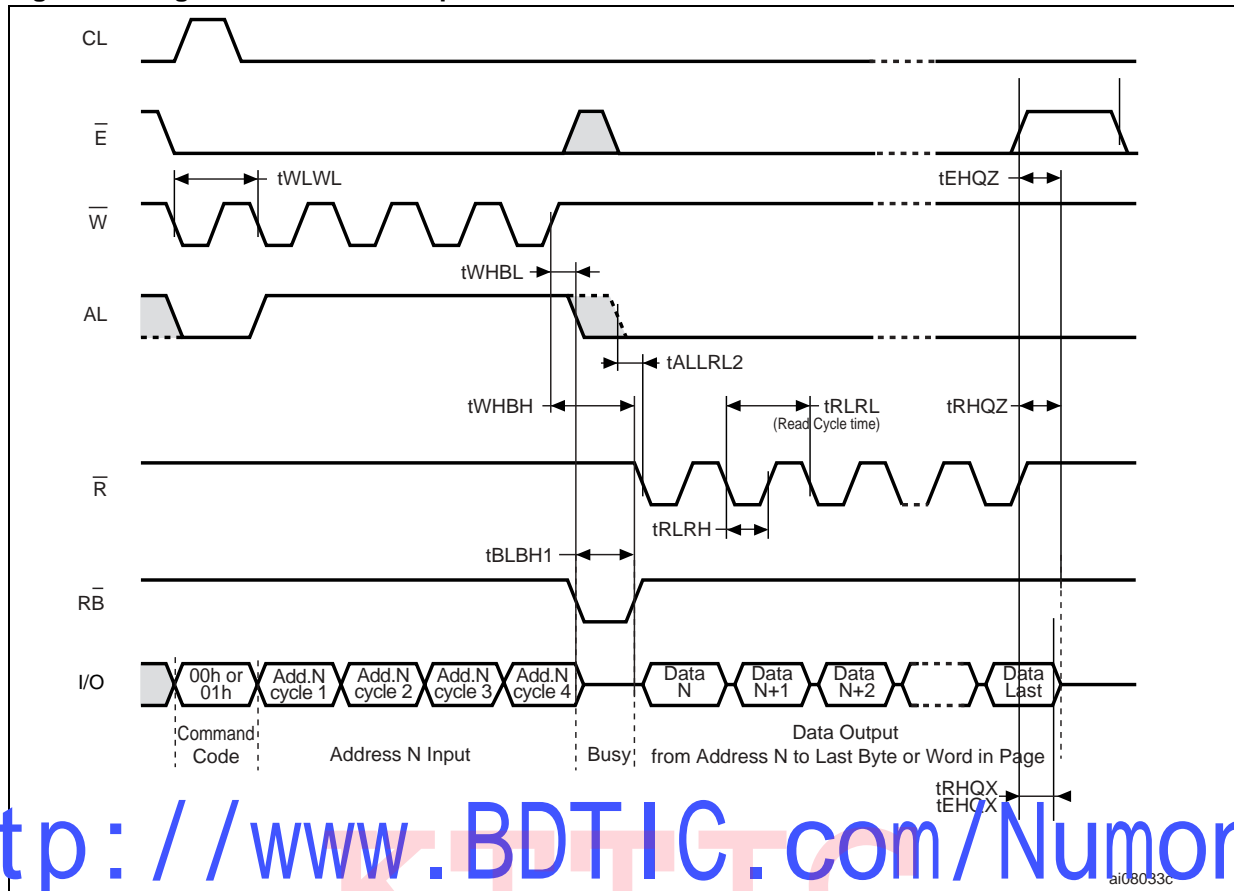
Note: Refer to Table 12. for the values of the Manufacturer and Device Codes.

<http://www.BDTIC.com/Numonyx>



NAND128-A, NAND256-A, NAND512-A, NAND01G-A

Figure 28. Page Read A/ Read B Operation AC Waveform

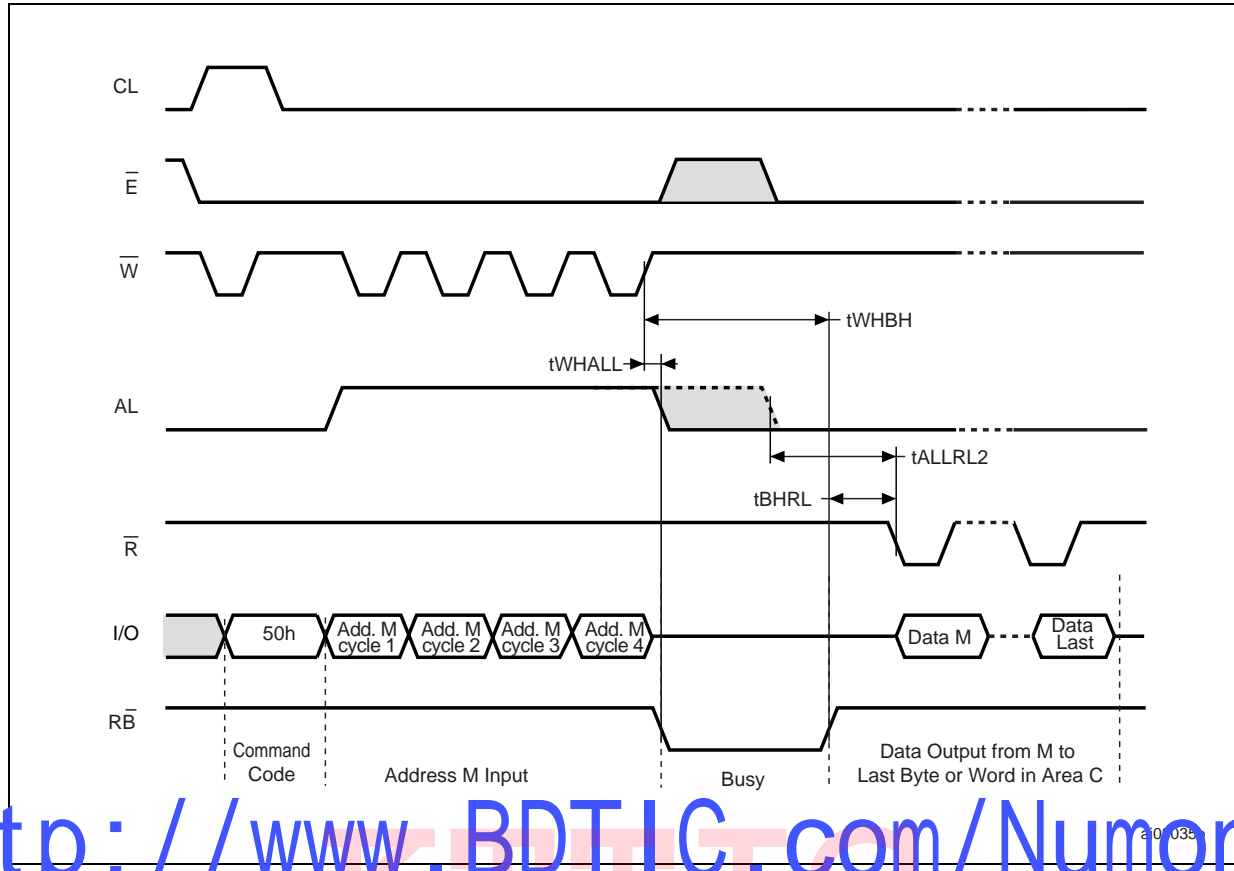


<http://www.BDTIC.com/Numonyx>

Note: Address cycle 4 is only required for 512Mb and 1Gb devices.

**NAND128-A, NAND256-A, NAND512-A, NAND01G-A**

**Figure 29. Read C Operation, One Page AC Waveform**

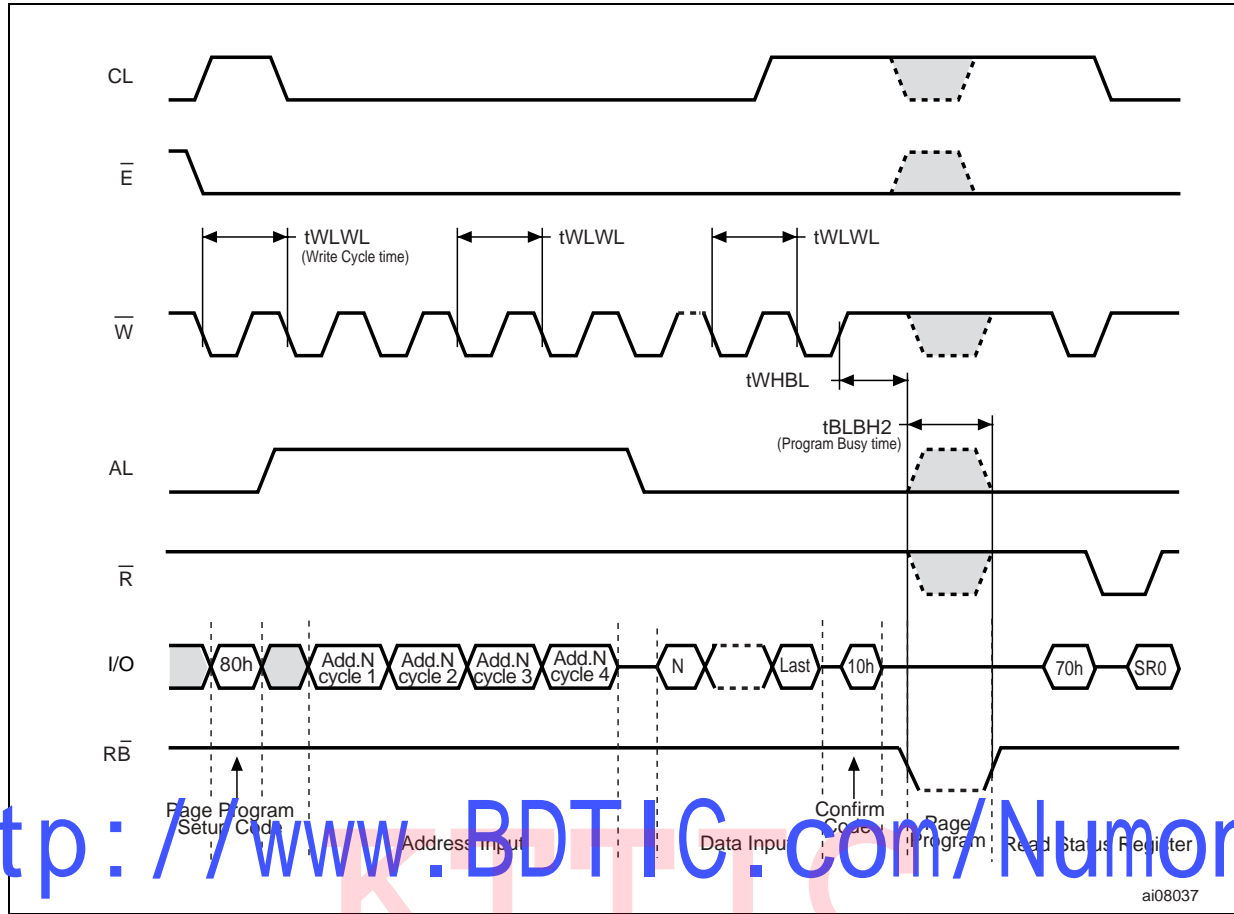


Not: 1. A0-A7 is the address in the Spare Memory area, where A0-A3 are valid and A4-A7 are 'don't care'.

<http://www.BDTIC.com/Numonyx>

NAND128-A, NAND256-A, NAND512-A, NAND01G-A

Figure 30. Page Program AC Waveform

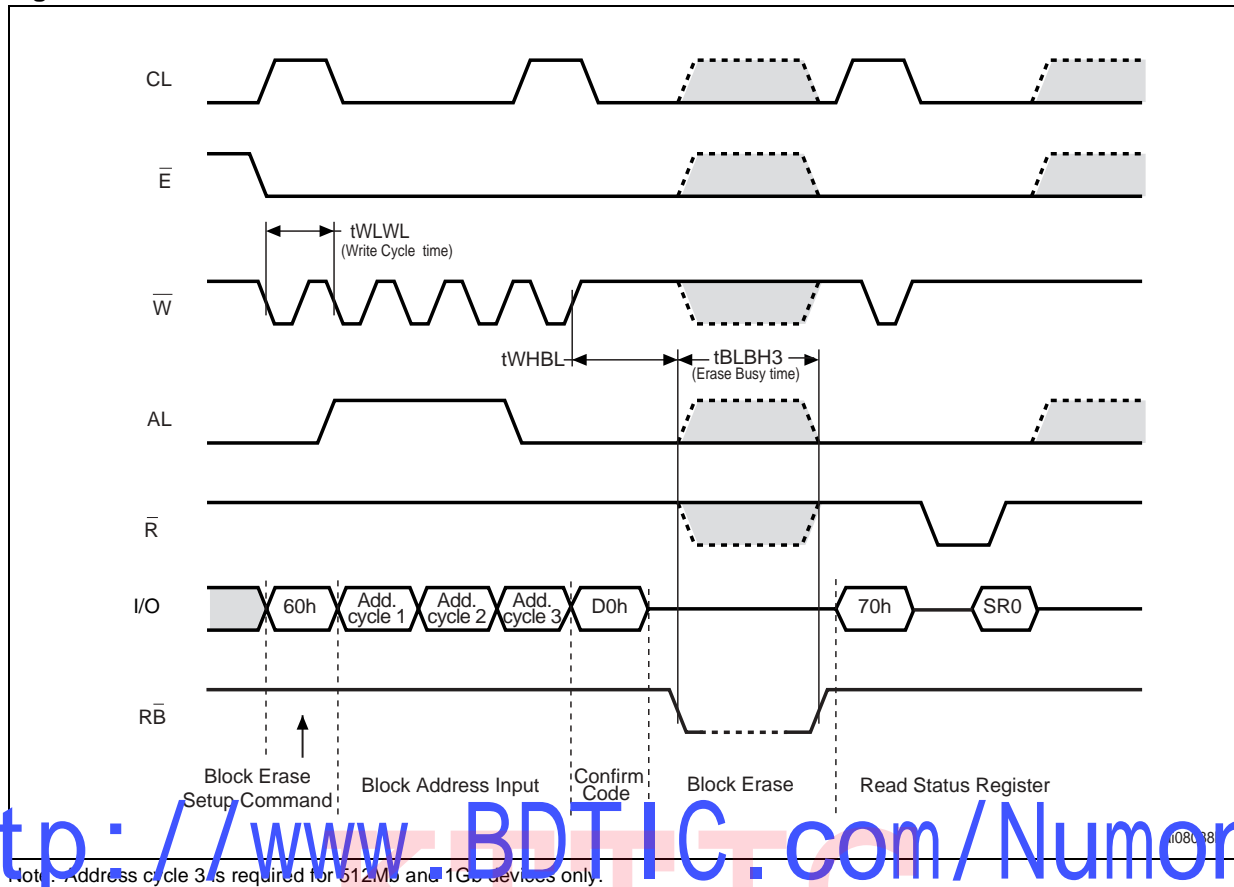


Note: Address cycle 4 is only required for 512Mb and 1Gb devices.

<http://www.BDTIC.com/Numonyx>

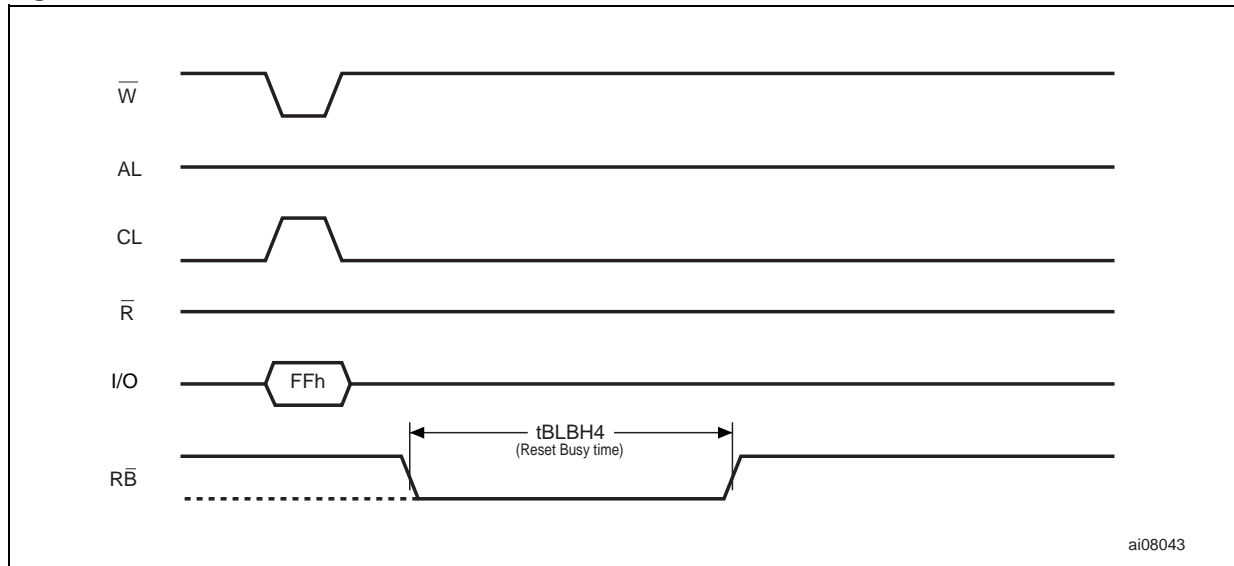
**NAND128-A, NAND256-A, NAND512-A, NAND01G-A**

**Figure 31. Block Erase AC Waveform**



<http://www.BDTIC.com/Numonyx>

**Figure 32. Reset AC Waveform**



NAND128-A, NAND256-A, NAND512-A, NAND01G-A

**Ready/Busy Signal Electrical Characteristics**

Figures 34, 33 and 35 show the electrical characteristics for the Ready/Busy signal. The value required for the resistor  $R_P$  can be calculated using the following equation:

$$R_{P\min} = \frac{(V_{DD\max} - V_{OL\max})}{I_{OL} + I_L}$$

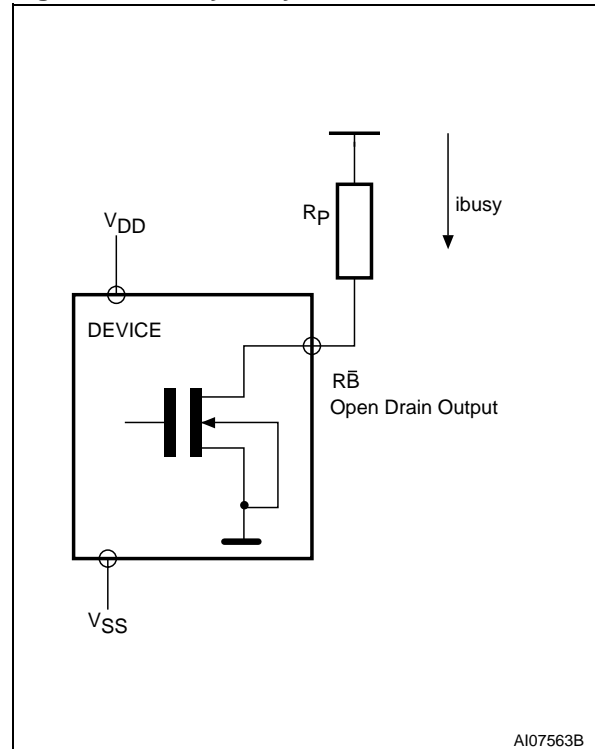
So,

$$R_{P\min}(1.8V) = \frac{1.85V}{3mA + I_L}$$

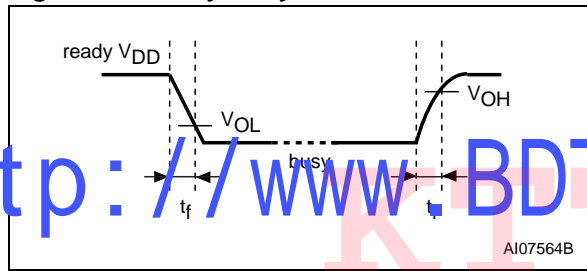
$$R_{P\min}(3V) = \frac{3.2V}{8mA + I_L}$$

where  $I_L$  is the sum of the input currents of all the devices tied to the Ready/Busy signal.  $R_P$  max is determined by the maximum value of  $t_r$ .

**Figure 34. Ready/Busy Load Circuit**

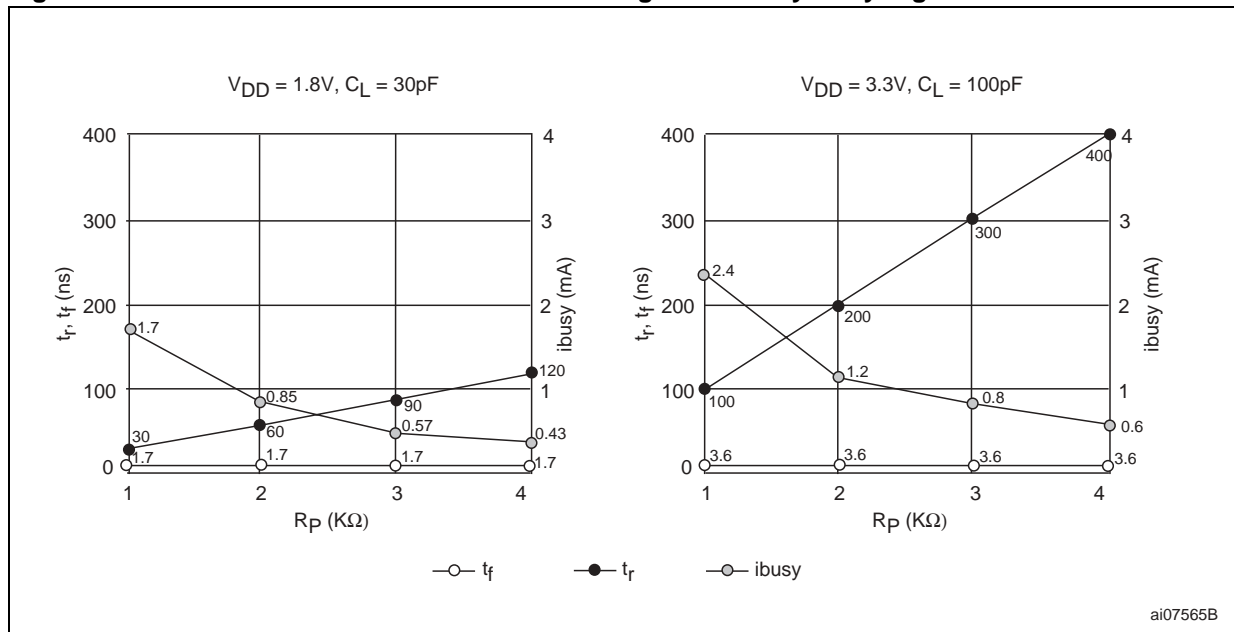


**Figure 33. Ready/Busy AC Waveform**



<http://www.BDTIC.com/Numonyx>

**Figure 35. Resistor Value Versus Waveform Timings For Ready/Busy Signal**



Note: T = 25°C.



**NAND128-A, NAND256-A, NAND512-A, NAND01G-A**

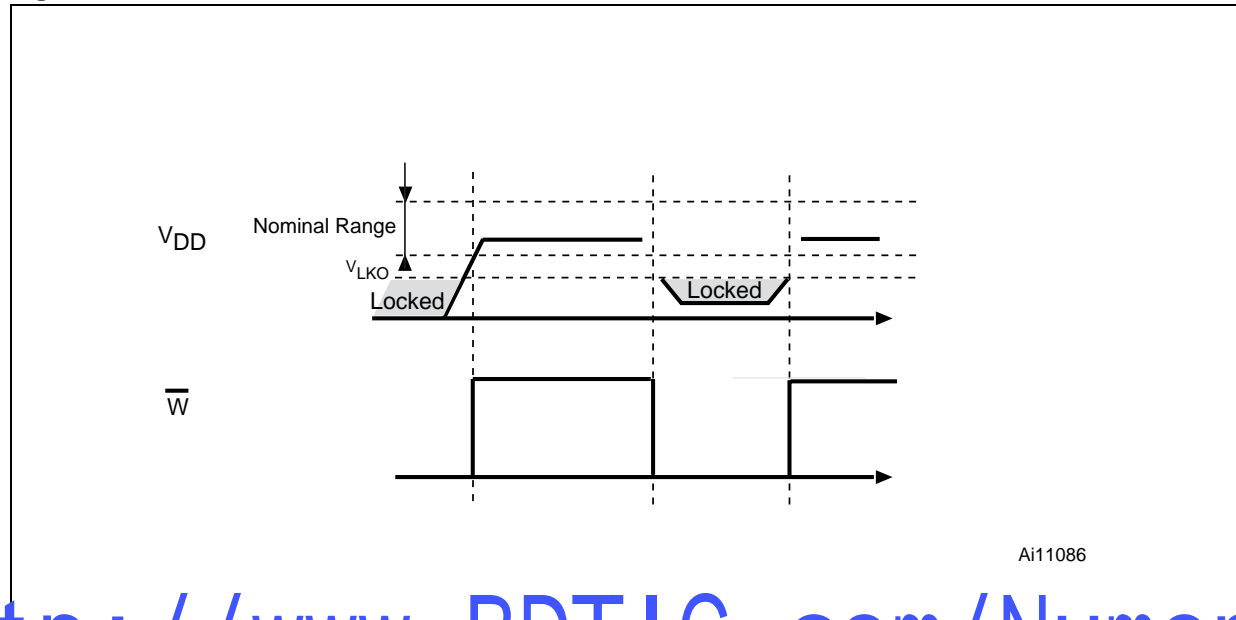
**Data Protection**

The ST NAND device is designed to guarantee Data Protection during Power Transitions.

A  $V_{DD}$  detection circuit disables all NAND operations, if  $V_{DD}$  is below the  $V_{LKO}$  threshold.

In the  $V_{DD}$  range from  $V_{LKO}$  to the lower limit of nominal range, the WP pin should be kept low ( $V_{IL}$ ) to guarantee hardware protection during power transitions as shown in the below figure.

**Figure 36. Data Protection**

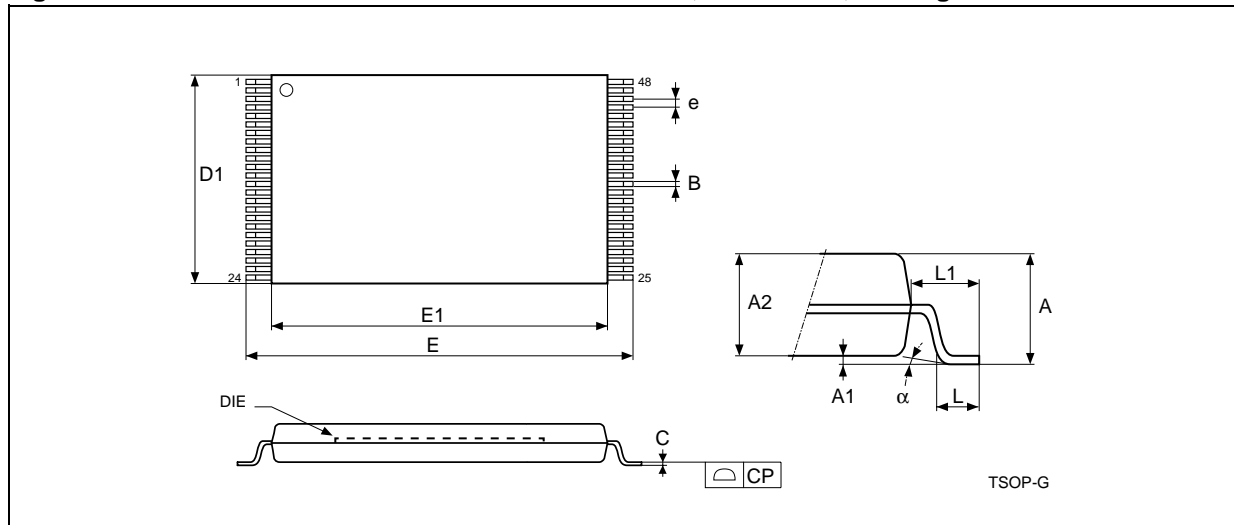


<http://www.BDTIC.com/Numonyx>

NAND128-A, NAND256-A, NAND512-A, NAND01G-A

PACKAGE MECHANICAL

Figure 37. TSOP48 - 48 lead Plastic Thin Small Outline, 12 x 20mm, Package Outline



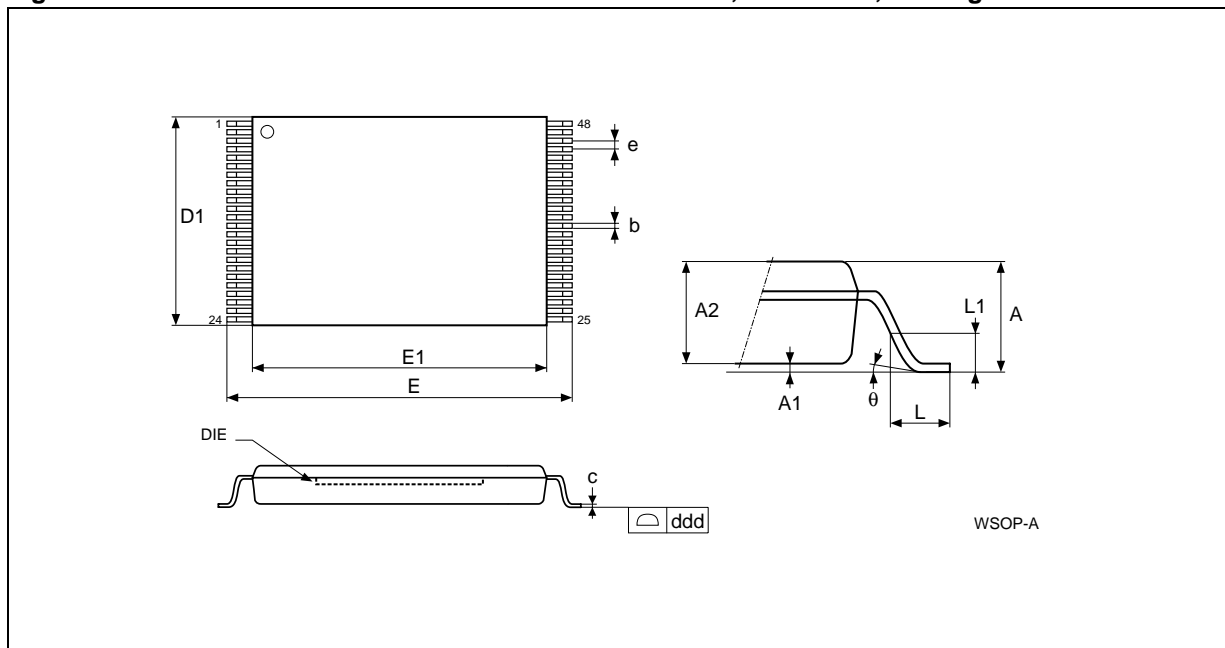
Note: Drawing is not to scale.

Table 22. TSOP48 - 48 lead Plastic Thin Small Outline, 12 x 20mm, Package Mechanical Data

Symbol	millimeters			inches		
	Typ	Min	Max	Typ	Min	Max
A			1.200			0.0472
A1	0.500	0.050	0.150	0.0039	0.0020	0.0059
A2	1.000	0.950	1.050	0.0394	0.0374	0.0413
B	0.220	0.170	0.270	0.0087	0.0067	0.0106
C		0.100	0.210		0.0039	0.0083
CP			0.080			0.0031
D1	12.000	11.900	12.100	0.4724	0.4685	0.4764
E	20.000	19.800	20.200	0.7874	0.7795	0.7953
E1	18.400	18.300	18.500	0.7244	0.7205	0.7283
e	0.500	-	-	0.0197	-	-
L	0.600	0.500	0.700	0.0236	0.0197	0.0276
L1	0.800			0.0315		
alpha	3°	0°	5°	3°	0°	5°

**NAND128-A, NAND256-A, NAND512-A, NAND01G-A**

**Figure 38. USOP48 – lead Plastic Ultra Thin Small Outline, 12 x 17mm, Package Outline**



Note: Drawing not to scale.

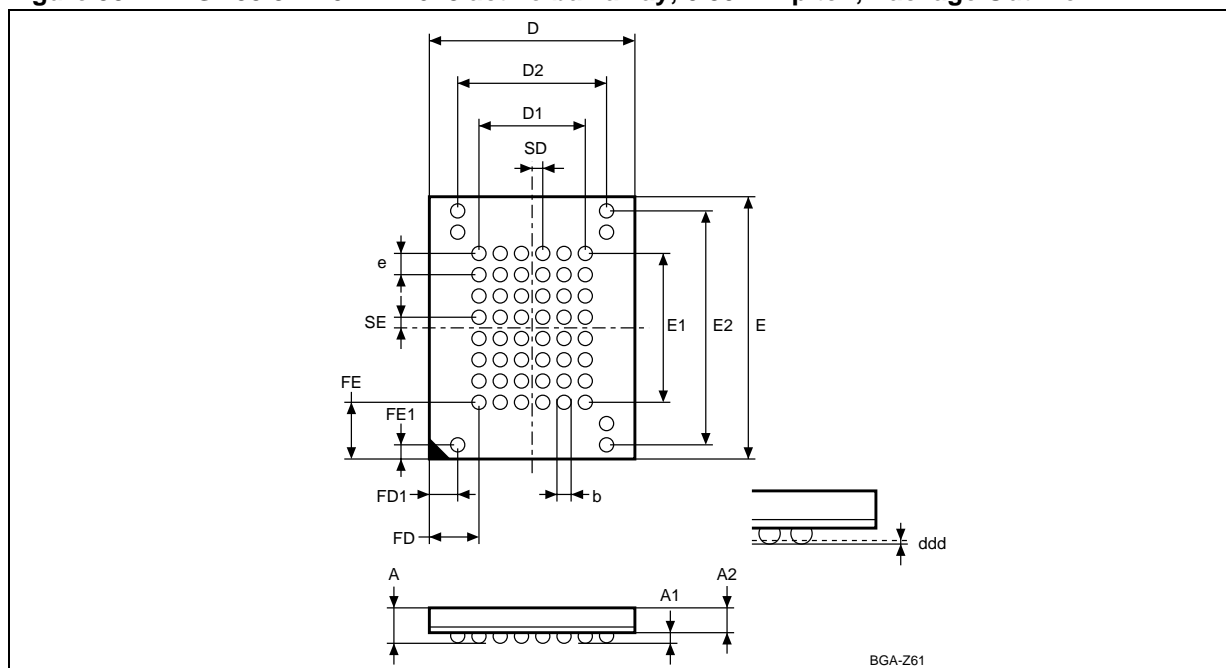
**Table 23. USOP48 – lead Plastic Ultra Thin Small Outline, 12 x 17mm, Package Mechanical Data**

Symbol	millimeters			inches		
	Typ	Min	Max	Typ	Min	Max
A		0.48	0.65		0.019	0.025
A1		0.00	0.10		0.000	0.004
A2	0.52	0.48	0.56	0.020	0.019	0.022
b	0.16	0.13	0.23	0.006	0.005	0.009
c	0.10	0.08	0.17	0.004	0.003	0.007
D1	12.00	11.90	12.10	0.472	0.469	0.476
ddd			0.06			0.002
E	17.00	16.80	17.20	0.669	0.661	0.677
E1	15.40	15.30	15.50	0.606	0.602	0.610
e	0.50	–	–	0.020	–	–
L	0.55	0.45	0.65	0.022	0.018	0.026
L1	0.25	–	–	0.010	–	–
q		0	5		0	5



NAND128-A, NAND256-A, NAND512-A, NAND01G-A

Figure 39. VFBGA55 8 x 10mm - 6x8 active ball array, 0.80mm pitch, Package Outline



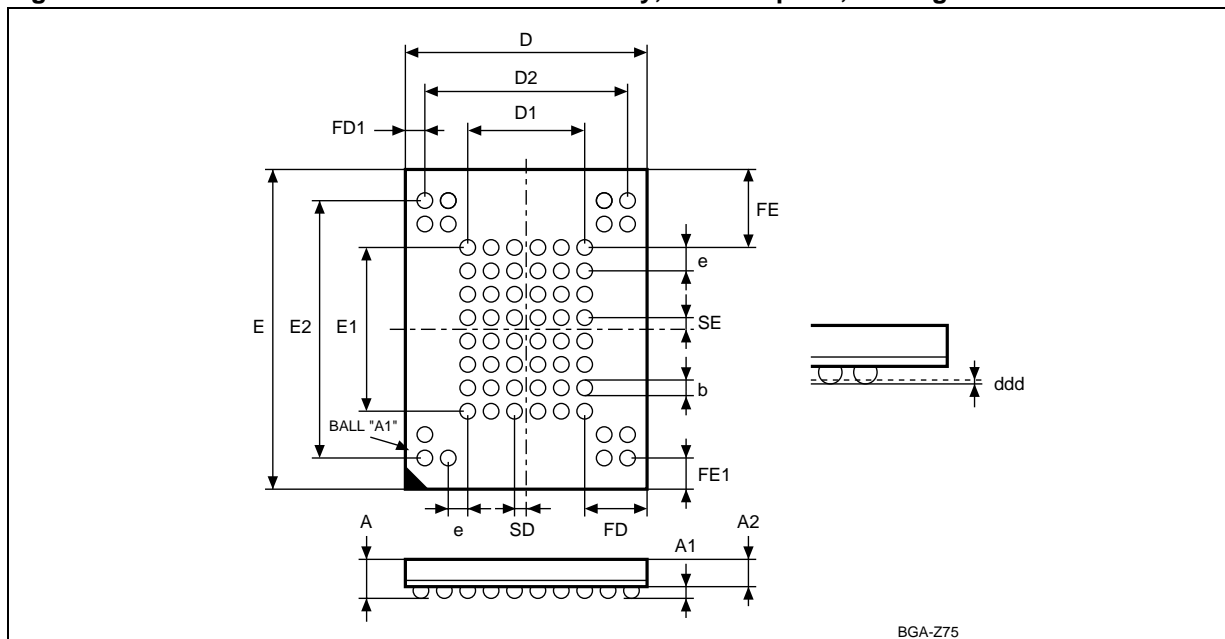
Note: Drawing is not to scale

Table 24. VFBGA55 8 x 10mm - 6x8 ball array, 0.80mm pitch, Package Mechanical Data

Symbol	millimeters			inches		
	Typ	Min	Max	Typ	Min	Max
A			1.05			0.041
A1		0.25		0.010		
A2			0.70			0.028
b	0.45	0.40	0.50	0.018	0.016	0.020
D	8.00	7.90	8.10	0.315	0.311	0.319
D1	4.00			0.157		
D2	5.60			0.220		
ddd			0.10			0.004
E	10.00	9.90	10.10	0.394	0.390	0.398
E1	5.60			0.220		
E2	8.80			0.346		
e	0.80	-	-	0.031	-	-
FD	2.00			0.079		
FD1	1.20			0.047		
FE	2.20			0.087		
FE1	0.60			0.024		
SD	0.40			0.016		
SE	0.40			0.016		

**NAND128-A, NAND256-A, NAND512-A, NAND01G-A**

**Figure 40. VFBGA63 9x11mm - 6x8 active ball array, 0.80mm pitch, Package Outline**



Note: Drawing is not to scale.

**Table 25. VFBGA63 9x11mm - 6x8 active ball array, 0.80mm pitch, Package Mechanical Data**

Symbol	millimeters			inches		
	Typ	Min	Max	Typ	Min	Max
A			11.10			0.437
A1		0.25			0.010	
A2			0.70			0.028
b	0.45	0.40	0.50	0.018	0.016	0.020
D	9.00	8.90	9.10	0.354	0.350	0.358
D1	4.00			0.157		
D2	7.20			0.283		
ddd			0.10			0.004
E	11.00	10.90	11.10	0.433	0.429	0.437
E1	5.60			0.220		
E2	8.80			0.346		
e	0.80	-	-	0.031	-	-
FD	2.50			0.098		
FD1	0.90			0.035		
FE	2.70			0.106		
FE1	1.10			0.043		
SD	0.40	-	-	0.016	-	-
SE	0.40	-	-	0.016	-	-

**NAND128-A, NAND256-A, NAND512-A, NAND01G-A**

**PART NUMBERING**

**Table 26. Ordering Information Scheme**



<http://www.BDTIC.com/Numonyx>

Devices are shipped from the factory with the memory content bits, in valid blocks, erased to '1'.  
For further information on any aspect of this device, please contact your nearest ST Sales Office.



**NAND128-A, NAND256-A, NAND512-A, NAND01G-A**

**APPENDIX A. HARDWARE INTERFACE EXAMPLES**

NAND Flash devices can be connected to a microcontroller system bus for code and data storage. For microcontrollers that have an embedded NAND controller the NAND Flash can be connected without the addition of glue logic (see Figure 41.). However a minimum of glue logic is required for general purpose microcontrollers that do not have an embedded NAND controller. The glue logic usually consists of a flip-flop to hold the Chip Enable, Address Latch Enable and Command Latch Enable signals stable during command and address latch operations, and some logic gates to simplify the firmware or make the design more robust.

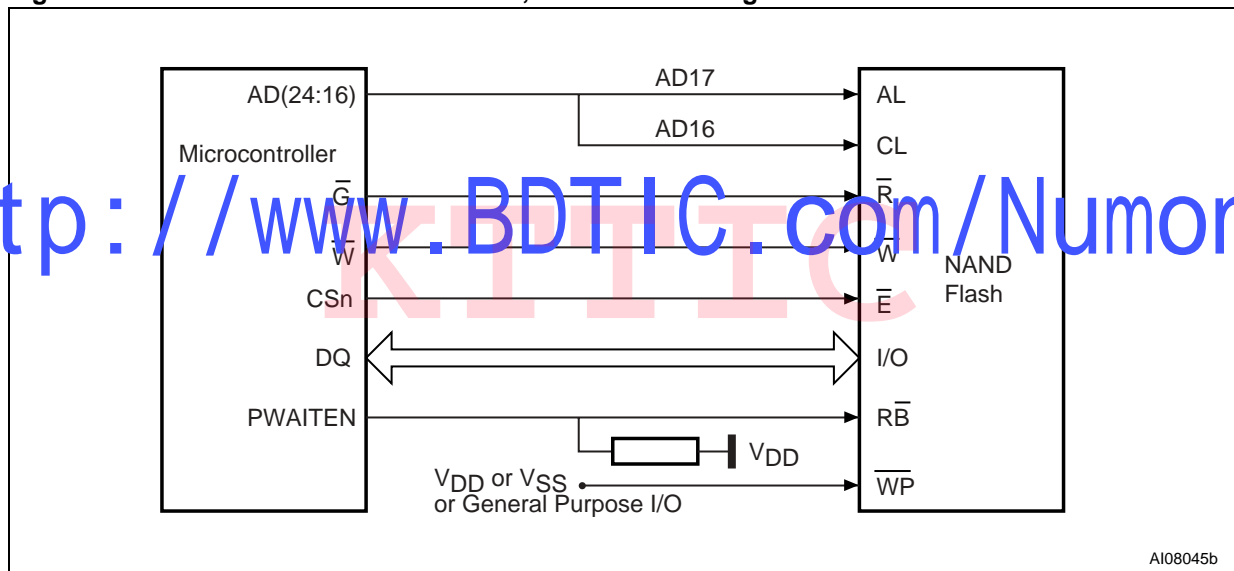
Figure 42. gives an example of how to connect a NAND Flash to a general purpose microcontroller. The additional OR gates allow the microcontroller's Output Enable and Write Enable signals to be used for other peripherals. The OR gate between

A3 and CSn maps the flip-flop and NAND I/O in different address spaces inside the same chip select unit, which improves the setup and hold times and simplifies the firmware. The structure uses the microcontroller DMA (Direct Memory Access) engines to optimize the transfer between the NAND Flash and the system RAM.

For any interface with glue logic, the extra delay caused by the gates and flip-flop must be taken into account. This delay must be added to the microcontroller's AC characteristics and register settings to get the NAND Flash setup and hold times.

For mass storage applications (hard disk emulations or systems where a huge amount of storage is required) NAND Flash memories can be connected together to build storage modules (see Figure 43.).

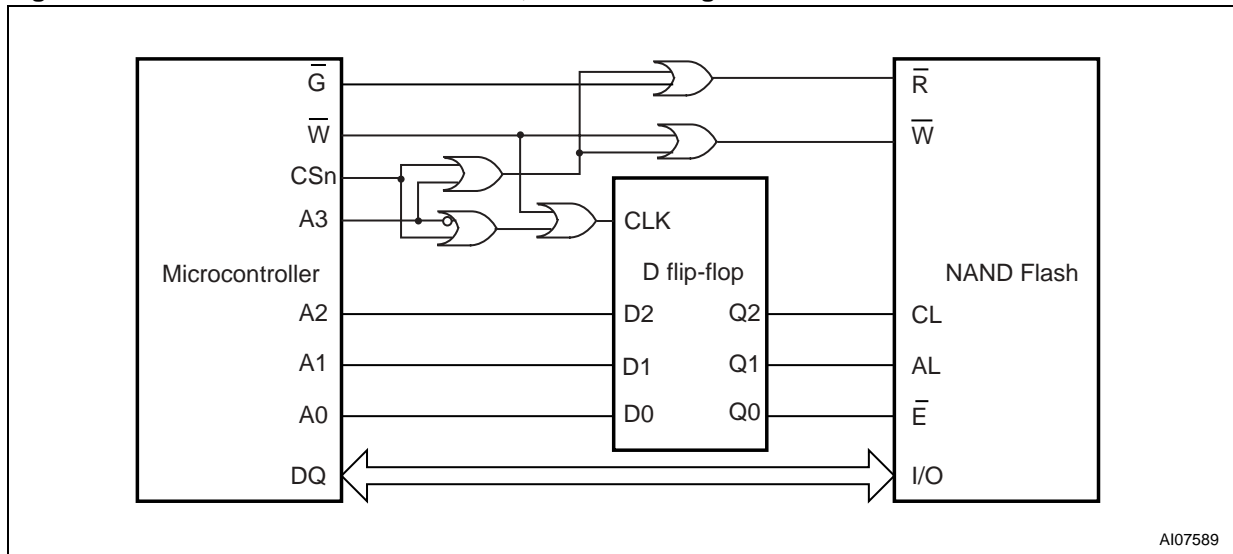
**Figure 41. Connection to Microcontroller, Without Glue Logic**



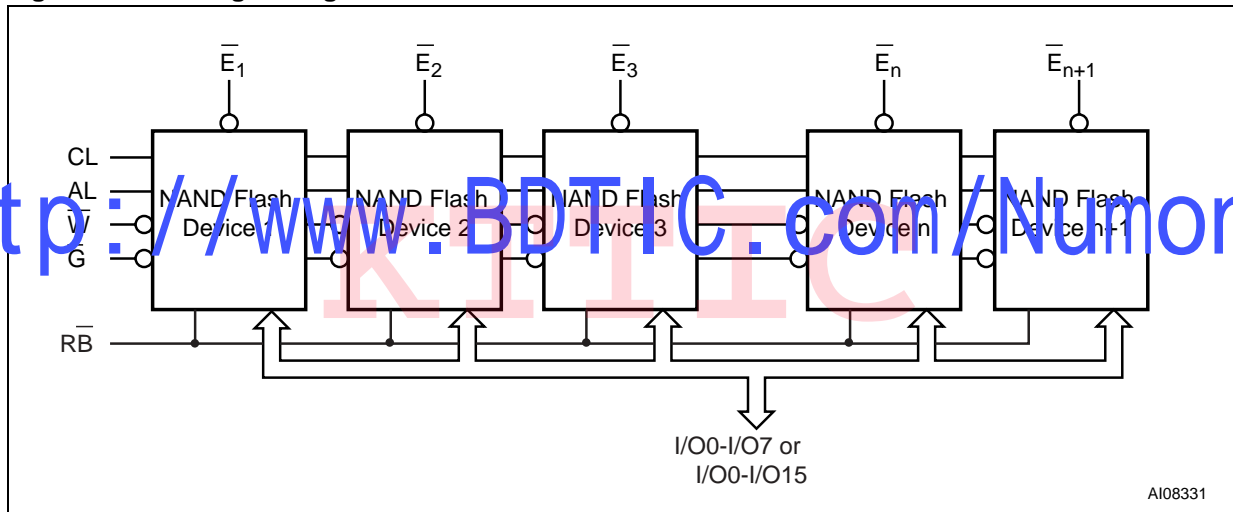
<http://www.BDTIC.com/Numonyx>

**NAND128-A, NAND256-A, NAND512-A, NAND01G-A**

**Figure 42. Connection to Microcontroller, With Glue Logic**



**Figure 43. Building Storage Modules**



**RELATED DOCUMENTATION**

STMicroelectronics has published a set of application notes to support the NAND Flash memories. They are available from the ST Website [www.st.com](http://www.st.com). or from your local ST Distributor.

**NAND128-A, NAND256-A, NAND512-A, NAND01G-A****REVISION HISTORY****Table 27. Document Revision History**

Date	Version	Revision Details
06-Jun-2003	1.0	First Issue
07-Aug-2003	2.0	Design Phase
27-Oct-2003	3.0	Engineering Phase
03-Dec-2003	4.0	Document promoted from Target Specification to Preliminary Data status. V <sub>CC</sub> changed to V <sub>DD</sub> and I <sub>CC</sub> to I <sub>DD</sub> . Title of Table 2.. changed to "Product Description" and Page Program Typical Timing for NANDXXXR3A devices corrected. Table 1., Product List, inserted on page 2.
13-Apr-2004	5.0	WSOP48 and VFPGA55 packages added, VFPGA63 (9 x 11 x 1mm) removed. Figure 19., Cache Program Operation, modified and note 2 modified. Note removed for t <sub>WLWH</sub> timing in Table 20., AC Characteristics for Command, Address, Data Input. Meaning of t <sub>BLBH4</sub> modified, partly replaced by t <sub>WHBH1</sub> and t <sub>WHRL</sub> min for 3V devices modified in Table 21., AC Characteristics for Operations. References removed from RELATED DOCUMENTATION section and reference made to ST Website instead. Figure 6., Figure 7., Figure 28. and Figure 31. modified. Read Electronic Signature paragraph clarified and Figure 27., Read Electronic Signature AC Waveform, modified. Note 2 to Figure 29., Read C Operation, One Page AC Waveform, removed. Note 3 to Table 7., Address Insertion, x16 Devices removed. Only 00h Pointer operations are valid before a Cache Program operation. I <sub>DD4</sub> removed from Table 18., DC Characteristics, 1.8V Devices. Note added to Figure 31., Block Erase AC Waveform. Small text changes.
28-May-2004	6.0	TFPGA55 package added (mechanical data to be announced). 512Mb Dual Die devices added. Figure 19., Cache Program Operation, modified. Package code changed for TFPGA63 (8.5 x 15 x 1.2mm, 6x8 ball array (0.8mm pitch) (1Gbit Dual Die devices) in Table 26., Ordering Information Scheme.
02-Jul-2004	7.0	Cache Program removed from document. TFPGA55 package specifications added (Figure 40., TFPGA55 8 x 10mm - 6x8 active ball array - 0.80mm pitch, Package Outline and Table 25., TFPGA55 8 x 10mm - 6x8 active ball array - 0.80mm pitch, Package Mechanical Data). Test conditions modified for V <sub>OL</sub> and V <sub>OH</sub> parameters in Table 19., DC Characteristics, 3V Devices.
01-Oct-2004	8.0	Third part number corrected in Table 1., Product List. 512 Mbit Dual Die information added to Table 10., Copy Back Program Addresses. Block Erase last address cycle modified. Definition of a Bad Block modified in Bad Block Management paragraph. RoHS COMPLIANCE added to SUMMARY DESCRIPTION. Figure 3., Logic Block Diagram modified. Document promoted from Preliminary Data to Full Datasheet status.
03-Dec-2004	9.0	Automatic Page 0 Read at Power-Up option no longer available. PC Demo board with simulation software removed from list of available development tools. Chip Enable (E) paragraph clarified.
13-Dec-2004	10.0	R <sub>ref</sub> parameter added to Table 16., Operating and AC Measurement Conditions. Description of the family clarified in the SUMMARY DESCRIPTION section.
25-Feb-2005	11.0	WSOP48 replaced with USOP48 package, VFPGA63 (8.5 x 15 x 1mm) replaced with VFPGA63 (9 x 11 x 1mm) package, TFPGA63 (8.5 x 15 x 1mm) replaced with TFPGA63 (9 x 11 x 1.2mm) package. Changes to Table 21., Table 18. and Table 2.

**NAND128-A, NAND256-A, NAND512-A, NAND01G-A**

Date	Version	Revision Details
23-June-2005	12.0	$t_{\text{EHBH}}$ , $t_{\text{EHEL}}$ , $t_{\text{RHBL}}$ removed throughout document. TFBGA63 and TFBGA55 packages removed throughout document. Sequential Row Read removed throughout document. $T_{\text{EHQX}}$ and $T_{\text{RHQX}}$ added throughout document. , <a href="#">Data Protection</a> section and <a href="#">Figure 21.</a> , <a href="#">Equivalent Testing Circuit For AC Characteristics Measurement</a> added. <a href="#">FEATURES SUMMARY</a> , <a href="#">SUMMARY DESCRIPTION</a> , <a href="#">Write Enable (W)</a> ., <a href="#">Chip Enable (E)</a> , <a href="#">Read Memory Array</a> , <a href="#">Page Program</a> , <a href="#">Read Electronic Signature</a> , <a href="#">Bad Block Management</a> and <a href="#">PART NUMBERING</a> modified. <a href="#">Figure 13.</a> and <a href="#">Figure 27.</a> modified. <a href="#">Table 1.</a> , <a href="#">Table 2.</a> , <a href="#">Table 10.</a> , <a href="#">Table 15.</a> , <a href="#">Table 16.</a> , <a href="#">Table 18.</a> and <a href="#">Table 19.</a> modified.
09-Aug-2005	13.0	Note added to <a href="#">Figure 4.</a> , <a href="#">TSOP48 and USOP48 Connections, x8 devices</a> and <a href="#">Figure 5.</a> , <a href="#">TSOP48 and USOP48 Connections, x16 devices</a> regarding the USOP package.

<http://www.BDTIC.com/Numonyx>

**NAND128-A, NAND256-A, NAND512-A, NAND01G-A**

---

<http://www.BDTIC.com/Numonyx>

Information furnished is believed to be accurate and reliable. However, STMicroelectronics assumes no responsibility for the consequences of use of such information nor for any infringement of patents or other rights of third parties which may result from its use. No license is granted by implication or otherwise under any patent or patent rights of STMicroelectronics. Specifications mentioned in this publication are subject to change without notice. This publication supersedes and replaces all information previously supplied. STMicroelectronics products are not authorized for use as critical components in life support devices or systems without express written approval of STMicroelectronics.

The ST logo is a registered trademark of STMicroelectronics.  
All other names are the property of their respective owners

© 2005 STMicroelectronics - All rights reserved

STMicroelectronics group of companies  
Australia - Belgium - Brazil - Canada - China - Czech Republic - Finland - France - Germany - Hong Kong - India - Israel - Italy - Japan -  
Malaysia - Malta - Morocco - Singapore - Spain - Sweden - Switzerland - United Kingdom - United States of America  
[www.st.com](http://www.st.com)



KTTIC <http://www.kttic.com>

# BDTIC 半导体事业部

<http://www.BDTIC.com/Numonyx>

备注：Numonyx 恒忆公司原由S T 意法半导体NANDFlash 存储器部门、Intel 英特尔 NORFlash存储器部门和Francisco Partners合资组建的闪存半导体公司。

Numonyx 恒忆公司产品部门

<http://www.kttic.com>